

TECHNICAL BULLETIN INSTALLATION INSTRUCTIONS

FOR SYSTEMS

SINGLE CHANNEL GROUND AND AIRBORNE RADIO SYSTEM (SINGARS)

AN/VRC-88F, AN/VRC-89F, AN/VRC-90F, AN/VRC-91F, AN/VRC-92F

FORCE XXI BATTLE COMMAND, BRIGADE-AND-BELOW (FBCB2)

AN/UYK-128 (V)4

PRECISION LIGHTWEIGHT GPS RECEIVER (PLGR)

AN/PSN-11

ENHANCED POSITION LOCATION REPORTING SYSTEM (EPLRS)

AN/VSQ-2 (V)

HF 20 WATT RADIO

FOR VEHICLES

**TRUCK, UTILITY, 2-DOOR: CARGO/TROOP CARRIER, 1-1/4 TON, 4X4,
M998 (2320-01-107-7155) (EIC: BBD); M998A1 (2320-01-371-9577) (EIC: BBN);**

**TRUCK, UTILITY, 2-DOOR: CARGO/TROOP CARRIER, 1-1/4 TON, 4X4,
M1038 (2320-01-107-7156) (EIC: BBE);**

**TRUCK, UTILITY, 2-DOOR: HEAVY VARIANT, 1-1/4 TON, 4X4,
M1097 (2320-01-346-9317) (EIC: BBM); M1097A1 (2320-01-371-9583) (EIC: BBU);
M1097A2 (2320-01-380-8604) (EIC: BB6).**

Approved for public release; distribution is unlimited.

HEADQUARTERS, DEPARTMENT OF THE ARMY

FEBRUARY 2006

LIST OF EFFECTIVE PAGES

NOTE

A vertical line in the outer margins of the page indicates the portion of text affected by the change.

Dates of issue for original and change pages are:

Original 0 28 February 2006

TOTAL NUMBER OF PAGES IN THIS PUBLICATION IS 127 PAGES.

Page No.	*Change No.
i-iii/iv (blank)0
1-1-5-89/(5-90 blank)0

*Zero in this column indicates original page.

TECHNICAL BULLETIN
NO. 9-2320-280-35-13

HEADQUARTERS,
DEPARTMENT OF THE ARMY
WASHINGTON, D.C., 28 February 2006

TECHNICAL BULLETIN
INSTALLATION INSTRUCTIONS

FOR SYSTEMS

**SINGLE CHANNEL GROUND AND AIRBORNE
RADIO SYSTEM (SINGARS)**
AN/VRC-88F, AN/VRC-89F, AN/VRC-90F, AN/VRC-91F, AN/VRC-92F

FORCE XXI BATTLE COMMAND, BRIGADE-AND-BELOW (FBCB2)
AN/UYK-128 (V)4

PRECISION LIGHTWEIGHT GPS RECEIVER (PLGR)
AN/PSN-11

ENHANCED POSITION LOCATION REPORTING SYSTEM (EPLRS)
AN/VSQ-2 (V)

HF 20 WATT RADIO

FOR VEHICLES

TRUCK, UTILITY, 2-DOOR: CARGO/TROOP CARRIER, 1-1/4 TON, 4X4,
M998 (2320-01-107-7155) (EIC: BBD); M998A1 (2320-01-371-9577) (EIC: BBN);

TRUCK, UTILITY, 2-DOOR: CARGO/TROOP CARRIER, 1-1/4 TON, 4X4,
M1038 (2320-01-107-7156) (EIC: BBE);

TRUCK, UTILITY, 2-DOOR: HEAVY VARIANT, 1-1/4 TON, 4X4,
M1097 (2320-01-346-9317) (EIC: BBM); M1097A1 (2320-01-371-9583) (EIC: BBU);
M1097A2 (2320-01-380-8604) (EIC: BB6).

REPORTING ERRORS AND RECOMMENDING IMPROVEMENTS

You can help improve this publication. If you find any mistakes or if you know of a way to improve the procedures, please let us know. Submit your DA Form 2028 (Recommended Changes to Publications and Blank Forms), through the Internet, on the Army Electronic Product Support (AEPS) website. The Internet address is <https://aeeps.ria.army.mil>. The DA Form 2028 is located in the ONLINE FORMS PROCESSING section of the AEPS. Fill out the form and click on SUBMIT. Using this form on the AEPS will enable us to respond quicker to your comments and better manage the DA Form 2028 program. You may also mail, fax or E-mail your letter or DA Form 2028 direct to: AMSTA-LC-LMIT / TECH PUBS, TACOM-RI, 1 Rock Island Arsenal, Rock Island, IL 61299-7630. The E-mail address is tacom-tech-pubs@ria.army.mil. The fax number is DSN 793-0726 or Commercial (309) 782-0726.

Approved for public release; distribution is unlimited.

TABLE OF CONTENTS

		Page
	LIST OF TABLES	iii
CHAPTER 1.	INTRODUCTION	1-1
Section I.	Scope	1-1
Section II.	Notes	1-1
Section III.	General Information	1-1
Section IV.	Maintenance Forms, Records, and Reports	1-1
Section V.	Consolidated Index of Army Publications	1-1
CHAPTER 2.	PURPOSE OF INSTALLATION	2-1
CHAPTER 3.	COMPLETION TIME FOR INSTALLATION	3-1
CHAPTER 4.	PREPARATION FOR INSTALLATION	4-1
Section I.	Preparation of Vehicle	4-1
Section II.	Items to be Removed	4-1
Section III.	List of Items to be Retained	4-1
Section IV.	Preparation of C4ISR Equipment	4-1
Section V.	Precautions During Handling	4-1
Section VI.	Unpack and Inspect Equipment	4-1
Section VII.	Inventory C4ISR Equipment	4-1
Section VIII.	Examine Each Item for Damage	4-2
Section IX.	C4ISR Equipment, Distribution, and Consumables	4-2
Section X.	Distribution and Issue Instructions	4-2
Section XI.	Parts List	4-2
CHAPTER 5.	INSTALLATION PROCEDURES	5-1
Section I.	Scope	5-1
Section II.	Installation of Terminal Boards	5-1
Section III.	Cab Enclosure Panel, Terminal Board, and Cover Modification	5-1
Section IV.	B-Beam Preparation	5-5
Section V.	Assembly of Cab Enclosure Panel	5-6
Section VI.	Final Assembly, Terminal Board Wiring, and Terminal Link	5-7
Section VII.	Integrated Rack Installation	5-12
Section VIII.	Installation of SINCGARS Mounting Tray and Amp Guard	5-14
Section IX.	Power Amplifier Installation	5-15
Section X.	FBCB2 Components Installation	5-17
Section XI.	Loudspeaker Installation	5-19
Section XII.	HF 20 Watt Radio Mount Installation	5-22
Section XIII.	Antenna Bracket and Antenna Installation	5-30
Section XIV.	Rear SINCGARS Antenna Installation	5-34

TABLE OF CONTENTS (Contd)

		Page
Section XV.	Cables Installation	5-38
Section XVI.	PLGR Bracket Installation	5-44
Section XVII.	PLGR Antenna and Cable Installation	5-45
Section XVIII.	EPLRS Mounting Installation	5-51
Section XIX.	EPLRS URO (User Readout) Installation	5-53
Section XX.	EPLRS and SINGARS Antenna Installation (Two-Man Vehicles)	5-54
Section XXI.	EPLRS Cables Installation (Two-Man Vehicles)	5-62
Section XXII.	Front SINGARS Cables Installation (Two-Man Vehicles)	5-68
Section XXIII.	EPLRS Cables Installation (Four-Man Vehicles)	5-70
Section XXIV.	Right-Side SINGARS Pedestal Antenna Installation (Four-Man Vehicles)	5-74
Section XXV.	Left-Side EPLRS Pedestal Antenna Installation (Four-Man Vehicles) . .	5-80
Section XXVI.	SINGARS Antenna Cables Installation (Four-Man Vehicles)	5-84
Section XXVII.	Loudspeaker Mount Installation	5-86
Section XXVIII.	Key Display Unit (KDU) Mount Installation	5-87
Section XXIX.	HF 20 Watt Radio Cables Installation	5-89

LIST OF TABLES

Table	Title	Page
4-1.	Kit Parts List for Installation of C4ISR Equipment	4-3
4-2.	Non-Kit Parts List for Installation of C4ISR Equipment	4-5

CHAPTER 1

INTRODUCTION

Section I. SCOPE

- 1-1.** This technical bulletin provides installation instructions for Command, Control, Communications, Computers, Intelligence, Surveillance, and Reconnaissance (C4ISR) equipment. The C4ISR equipment shall be installed in the following vehicles:
- Truck, Utility, 2-Door: Cargo/Troop Carrier, 1-1/4 Ton, 4x4, M998, M998A1
 - Truck, Utility, 2-Door: Cargo/Troop Carrier, 1-1/4 Ton, 4x4, M1038
 - Truck, Utility, 2-Door: Heavy Variant, 1-1/4 Ton, 4x4, M1097, M1097A1, M1097A2
- 1-2.** The information contained in this technical bulletin is the official authorization to perform the installation of the C4ISR equipment at the direct support maintenance level through contract maintenance teams.

Section II. NOTES

- 2-1.** This technical bulletin is not an authorization for requisition or turn-in of vehicles.
- 2-2.** This technical bulletin does not establish quantity or types of vehicles assigned to using units.

Section III. GENERAL INFORMATION

- 3-1.** Included in the C4ISR equipment are:
- Single Channel Ground and Airborne Radio System (SINCGARS), Radio Set AN/VRC-88F/89F/90F/91F/92F Series
 - Force XXI Battle Command, Brigade-and-Below (FBCB2), AN/UYK-128 (V)4
 - Precision Lightweight Global Positioning System Receiver (PLGR), AN/PSN-11
 - Enhanced Position Location Reporting System (EPLRS), MK-2467A/NSQ-1
 - HF 20 Watt Radio
 - Additional terminal boards
- 3-2.** The C4ISR equipment becomes operable when all the components are installed in the vehicle and correct power is supplied.

Section IV. MAINTENANCE FORMS, RECORDS, AND REPORTS

Use the following to report any discrepancies:

- Reports of Maintenance and Unsatisfactory Equipment. See chapter 4, sections VI through VIII for information.
- Reports of Packaging and Handling Deficiencies. See chapter 4, sections VI through VIII for information.

Section V. CONSOLIDATED INDEX OF ARMY PUBLICATIONS

Refer to the latest issue of DA PAM 25-30 to determine whether there are new changes or additional publications pertaining to the C4ISR equipment.

CHAPTER 2

PURPOSE OF INSTALLATION

The purpose of installing the C4ISR equipment is to provide the primary means of integrating command and control capability.

CHAPTER 3

COMPLETION TIME FOR INSTALLATION

A total of 20 man-hours are required for two personnel to install the C4ISR equipment. Typical vehicle downtime is 12 hours.

CHAPTER 4

PREPARATION FOR INSTALLATION

Section I. PREPARATION OF VEHICLE

Ensure that the site includes adequate lighting and a power source when drilling is required. Inspect the vehicle for damage that could affect installation. Have any such damage repaired before installing the C4ISR equipment.

Section II. ITEMS TO BE REMOVED

- 2-1. Remove batteries. (Refer to TM 9-2320-280-20.)
- 2-2. Remove left- and right-hand rear door, as applicable. (Refer to TM 9-2320-280-20.)
- 2-3. Remove left- and right-hand rear cab enclosure panel, as applicable. (Refer to TM 9-2320-280-20.)
- 2-4. Remove center tunnel insulation, as applicable. (Refer to TM 9-2320-280-20.)
- 2-5. Remove standard radio rack. (Refer to TM 9-2320-280-20.)
- 2-6. Remove cargo bulkhead. (Refer to TM 9-2320-280-20.)

Section III. LIST OF ITEMS TO BE RETAINED

- 3-1. Batteries.
- 3-2. Left- and right-hand rear cab enclosure panel (if applicable).
- 3-3. Left- and right-hand rear fixed door (if applicable).

Section IV. PREPARATION OF C4ISR EQUIPMENT

Unpack, inspect, and check inventory.

Section V. PRECAUTIONS DURING HANDLING

Observe the following precautions to prevent equipment damage.

- a. Keep dust covers in place on connectors.
- b. Do not disassemble or modify parts in the C4ISR equipment unless authorized to do so.
- c. Keep mounting hardware covered and protected until needed.

Section VI. UNPACK AND INSPECT EQUIPMENT

- 6-1. Unpack and inspect packaging for evidence of damage.
- 6-2. Report any shipping damage on SF 364 Report of Discrepancy (ROD) as prescribed in AR 735-11-2/DLAR 4140.55/NAVMATINST 4355.73A/AFR 400-64/MCO 4430.F.

Section VII. INVENTORY C4ISR EQUIPMENT

If any item is missing, fill out and forward Transportation Discrepancy Report (TDR) (SF 361) as described in AR 55-38/NAVSUPINST 4610.33C/AFR 75-18/MCO P4610.19D/DLAR 450015.

Section VIII. EXAMINE EACH ITEM FOR DAMAGE

If any item is damaged, fill out and forward SF 364 Report of Discrepancy (ROD) as prescribed in AR 735-11-2/DLAR 4140.55/NAVMATINST 4355.73A/AFR 400-64/MCO 4430.F. All damages should be reported as prescribed by DA PAM 738-750, as contained in the Maintenance Management Update.

Section IX. C4ISR EQUIPMENT, DISTRIBUTION, AND CONSUMABLES

- 9-1. Use table 4-1 to identify and inventory C4ISR equipment installation parts supplied in kits.
- 9-2. Use table 4-2 to identify and inventory C4ISR equipment installation parts not supplied in kits.

Section X. DISTRIBUTION AND ISSUE INSTRUCTIONS

- 10-1. U.S. Forces: Do not requisition C4ISR equipment. It will be shipped automatically.
- 10-2. U.S. Army Depots: Requisition C4ISR equipment through supply channels.
- 10-3. Multiservice: Instructions shall be included for multiservice modifications.
- 10-4. MAP/MAS countries: Instructions shall be provided for MAP/MAS countries.

Section XI. PARTS LIST

KITS REQUIRED FOR THIS INSTALLATION:

NOTE

- Not all material in kits is required for this installation. Material not used during installation will be returned to stock for disposition in accordance with AR 725-50.
- If maintenance is to be performed on a vehicle with an existing kit, do not order entire kit for necessary reinstallation.

SINGARS:

- (A): MK-2325
- (B): MK-2326
- (C): MK-2327 (dual)
- (D): MK-2328 (double kit)

PLGR:

- (E): 57K4400

EPLRS:

- (F): MK-2467A/VSQ-1
- (G): MK-2753/VSQ

HF 20 WATT RADIO:

- (H): No kits available

FBCB2:

- (I): No kits available

MATERIAL REQUIRED FROM KITS:*Table 4-1. Kit Parts List for Installation of CAISR Equipment.*

ITEM NO.	NOMENCLATURE	PART NUMBER	NSN	KIT	QTY.
1.	Bracket, Antenna	A3014546-1	5340-01-391-2742	(A),(B),(C),(D)	1
2.	Bracket, Multiple Angle-Left	A3018371-1	5340-01-392-2217	(C),(D)	1
3.	Bracket, Multiple Angle-Left	A3018372-1	5340-01-392-2216	(C),(D)	1
4.	Bracket, Multiple Angle-Right	A3018371-2	5340-01-425-8010	(C)	1
5.	Bracket, Multiple Angle-Right	A3018372-2	5340-01-425-5600	(C)	1
6.	Bracket, PLGR Mount	12480578	N/A	(E)	1
7.	Cable Assembly, Antenna	A3014031-17	5995-01-225-1660	(B),(C),(D)	2
8.	Cable Assembly, Antenna, EPLRS	SM-C-911480	5995-01-167-1269	(F),(G)	1
9.	Cable Assembly, Power, Electrical	A3014040-9	5995-01-300-9324	(B),(C),(D)	1
10.	Cable Assembly, Power, EPLRS	A3004939	5995-01-198-0538	(F),(G)	1
11.	Cable Assembly, Radio Frequency	A3014031-8	5995-01-219-7035	(A),(B),(C),(D)	2
12.	Cable Assembly, Radio Frequency	A3014032-3	5995-01-219-7025	(B),(C),(D)	1
13.	Clamp, Loop	MS21333-71	5340-00-057-2904	(B),(C),(D)	3
14.	Clamp, Loop	MS21333-75	5340-00-050-2740	(A),(B),(C),(D)	10
15.	Clamp, Loop	MS21333-77	5340-00-922-6300	(A),(B),(C),(D)	15
16.	Clamp, Loop	MS21333-96	5340-00-088-1255	(E)	2
17.	Clamp, Loop	MS21333-98	5340-00-809-1490	(A),(B),(C),(D)	7
18.	Clamp, Loop	MS21333-102	5340-00-984-8540	(B)	4
19.	Clamp, Loop	MS21333-112	5340-00-057-3043	(B),(C),(D)	3
20.	Fiber Rope Assembly, Single Leg	A3167672-1	4020-01-341-8795	(A),(B),(C),(D),(G)	2
21.	Gasket	A3013655-1	5330-01-205-2864	(A),(B),(C),(D)	3
22.	Grommet, Nonmetallic	MS21266-4N	5325-00-923-9512	(C),(D)	2
23.	Grommet, Nonmetallic	MS35489-143	5325-00-292-7558	(E)	2
24.	Insert	12446871-2	5310-01-411-3422	(E)	3
25.	Loudspeaker	A3014065-1	5965-01-222-1420	(A),(B),(C),(D)	2
26.	Mounting Base, Electrical Equipment	A3013367-1	5975-01-188-8873	(A),(B),(C),(D),(G)	1
27.	Mounting Base, Electrical Equipment	A3014053-1	5975-01-235-1962	(B),(C)	1
28.	Nut	MS35650-302	5310-00-934-9751	(A),(B),(C), (D),(F),(G)	1
29.	Nut	MS51967-2	5310-00-761-6882	(A),(B),(C), (D),(F),(G)	16
30.	Nut	MS51968-5	5310-00-880-7746	(A),(B),(C),(D),(G)	2
31.	Nut	271169	5310-00-124-9265	(E)	5

MATERIAL REQUIRED FROM KITS (Contd):

Table 4-1. Kit Parts List for Installation of C4ISR Equipment (Contd).

ITEM NO.	NOMENCLATURE	PART NUMBER	NSN	KIT	QTY.
32.	Nut	9419143	5310-01-148-0240	(E)	43
33.	Nut	9422771	5310-01-211-0691	(E)	3
34.	Nut, Lock	271175	5310-01-333-5245	(E)	6
35.	Nut Strip	A3014064-1	N/A	(B),(C),(D)	1
36.	Plate, Mounting	A3014550-1	N/A	(A),(B),(C),(D)	2
37.	Plate, Mounting Assembly, Sponson	A3046204	5340-01-237-8094	(F)	1
38.	Screw	MS35224-65	5310-00-543-5743	(F)	1
39.	Screw	MS35190-291	5305-00-958-5247	(B)	2
40.	Screw	MS35206-263	5305-00-984-6210	(E)	4
41.	Screw	MS35206-265	5305-00-984-6212	(E)	1
42.	Screw, Cap	B1821BH025C100N	5305-00-225-3843	(E)	3
43.	Screw, Cap	B1821BH025C125N	5305-00-068-0509	(E)	2
44.	Screw, Cap	MS35307-365	5305-00-847-1159	(A),(B),(C),(D),(G)	8
45.	Screw, Self-Tapping	9421073	5305-01-162-8512	(E)	6
46.	Screw, Self-Tapping	1234299-1	N/A	(A),(B),(C),(D)	3
47.	Strap, Tiedown	MS3367-1-0	5975-00-984-6582	(E)	2
48.	Terminal Lug	7728777	5940-00-983-4067	(E)	1
49.	Terminal Lug	7728780	5940-01-035-4212	(E)	2
50.	Washer	MS27183-10	5310-00-809-4058	(C),(D),(G)	11
51.	Washer	2436161	5310-01-102-3270	(E)	6
52.	Washer, Lock	MS35338-43	5310-00-045-3296	(A),(B),(C),(D), (E),(F),(G)	4
53.	Washer, Lock	MS35338-44	5310-00-582-5965	(A),(B),(C),(D),(E),(G)	34
54.	Washer, Lock	MS35338-46	5310-00-637-9541	(C),(D),(F),(G)	2
55.	Washer, Lock	MS35338-48	5310-00-584-5272	(C),(D)	3
56.	Washer, Lock	MS45904-68	5310-00-889-2528	(A),(B),(C),(D)	25
57.	Washer, Lock	MS45904-71	5310-00-947-6980	(E),(G)	5
58.	Washer, Lock	MS45904-72	5310-00-889-2527	(A),(B),(C), (D),(F),(G)	50
59.	Washer, Lock	MS45904-76	5310-00-061-1258	(A),(B),(C),(D),(G)	12
60.	Wellnut	12339397-3	5310-01-231-7455	(E)	1
61.	Wellnut	12339397-6	5310-01-388-6205	(E)	1

MATERIAL REQUIRED BUT NOT INCLUDED IN KITS:*Table 4-2. Non-Kit Parts List for Installation of C4ISR Equipment.*

ITEM NO.	NOMENCLATURE	PART NUMBER	NSN	QTY.
1.	Adapter, Antenna (tilt)	RF-1980-AT001	5985-01-519-6245	1
2.	Antenna	4245	5985-01-499-4898	1
3.	Antenna	A3005031	5820-01-183-9462	1
4.	Antenna AS-3900/VRC	A3017889-2	5985-01-308-8988	2
5.	Antenna, Element (lower)	A3018230-1	5985-01-201-1498	2
6.	Antenna, Element (upper)	A3017901-2	5985-01-306-4622	2
7.	Antenna, PLGR	AT575-030	5985-01-375-4660	1
8.	Assembly, Display Lock	872843-01	N/A	1
9.	Bar, Support	10181-5213-002	N/A	1
10.	Block, Clamp	12018-1905-01	N/A	1
11.	Bolt	MS35751-18	5306-00-108-9988	4
12.	Bracket, Antenna Base	RF292	5985-01-418-5247	1
13.	Bracket, Antenna Base	A3050655-1	5340-01-412-4379	2
14.	Bracket, PLGR	986-0645-001	5975-01-375-1302	1
15.	Bracket, User Readout (URO)	A3006206	5340-01-386-7841	1
16.	Cable Assembly, Antenna, HF	10564-3355-A004	N/A	1
17.	Cable Assembly, Antenna, PLGR	426-0141-050	6150-01-375-8662	1
18.	Cable Assembly, Ground	12480567-1	N/A	1
19.	Cable Assembly, INC-EPUU	A3279383-3	5995-01-453-9171	1
20.	Cable Assembly, power (HF)	10181-9826-020	N/A	1
21.	Cable Assembly, Power	12480567-2	N/A	1
22.	Cable Assembly, Power, PLGR	9728558-10	6150-01-375-8661	1
23.	Cable Assembly, RT Speaker	10535-0707-A020	N/A	1
24.	Cable Assembly, Speaker Power	10535-0708-A020	N/A	1
25.	Cable Assembly, User Readout (URO)	A3005328	5995-01-375-2439	1
26.	Cable, Control	A3014037-4	5995-01-335-7863	1
27.	Cable, KDU	10511-0704-040	N/A	1
28.	Cable, Speaker	A3014038-3	5995-01-219-4704	2
29.	Clamp, Loop	MS21333-65	5340-00-905-0790	3
30.	Clamp, Loop	MS21333-66	5340-00-990-7610	3
31.	Clamp, Loop	MS21333-69	5340-00-764-7051	4
32.	Clamp, Loop	MS21333-72	5340-00-091-3790	2
33.	Clamp, Loop	MS21333-74	5340-00-989-9222	7
34.	Clamp, Loop	MS21333-104	5340-00-088-1254	2
35.	Clamp, Loop	MS21333-121	5340-00-954-6014	1
36.	Cover	11080-5425-01	N/A	1
37.	Cover, Antenna Bracket	1018-5212-02	N/A	1
38.	CPU (Central Processing Unit)	881292-1	7021-01-474-3793	1
39.	Decal	12339060	7690-01-265-1135	1
40.	Decal	861868-2	N/A	1

MATERIAL REQUIRED BUT NOT INCLUDED IN KITS (Contd):*Table 4-2. Non-Kit Parts List for Installation of C4ISR Equipment (Contd).*

ITEM NO.	NOMENCLATURE	PART NUMBER	NSN	QTY.
41.	Display	881293-1	7025-01-475-0229	1
42.	Grommet, Nonmetallic	12338098	5325-01-308-5424	1
43.	Grommet	2400	5325-01-289-7859	1
44.	Grommet	MS21266-1N	5325-00-960-2410	A/R
45.	Grommet	MS21266-4N	5325-00-923-9512	A/R
46.	Grommet	MS35489-24	5325-01-452-0384	2
47.	Guard, Amp	872842-1	5935-01-487-2172	1
48.	Insert	12446871-2	5310-01-411-3422	3
49.	Isolation Kit, CPU	872826-2	5340-01-481-5741	1
50.	Isolation Kit, Display	872870-1	5340-01-481-5757	1
51.	Lanyard	8925T5-7X19	4010-01-497-2675	1
52.	Lanyard	Z33-0002-306	N/A	1
53.	Locking Bar	12018-1908-01	N/A	1
54.	Locking Base	12018-1907-01	N/A	1
55.	Locking Collar	Z52-0013-002	N/A	2
56.	Mount, Antenna Overcab	A3265061	N/A	1
57.	Mount, KDU	11071-0900-04	N/A	1
58.	Mount, Ramball	RAM-D-111U	5975-01-485-3615	1
59.	Mount, Resilient	MT-6146/VSQ-1	5340-01-167-8297	1
60.	Nut	116002	5310-01-125-1216	4
61.	Nut	MS35649-2252	5310-00-997-1888	3
62.	Nut	13218E0320-293	5310-00-913-8881	18
63.	Nut	9418892	5310-01-157-9819	14
64.	Nut	MS35649-63	5310-00-804-3859	5
65.	Nut	9417954	5310-00-931-8167	8
66.	Nut	271166	5310-00-696-5172	3
67.	Nut	9422771	5310-01-211-0691	1
68.	Nut	MS35649-2382	5310-00-056-3395	2
69.	Nut, Nylon	10075-1397	N/A	2
70.	Panel, Enclosure	12447141	2510-01-413-5993	1
71.	Plate, Antenna	A3104004-1	N/A	2
72.	Plate, Antenna	A3157619	9515-01-374-7165	2
73.	Rack, Integrated	A3276903	N/A	2
74.	Rail, Left Overhead	A3265060-001	N/A	1
75.	Rail, Right Overhead	A3265060-002	N/A	1
76.	Rivet, Blind	12339355-1	5320-01-271-6357	2
77.	Screw	9417875	N/A	4
78.	Screw	160035	5305-00-016-0035	1
79.	Screw	MS35206-230	5305-00-889-3000	5
80.	Screw	MS35206-265	5305-00-984-6212	6

MATERIAL REQUIRED BUT NOT INCLUDED IN KITS (Contd):*Table 4-2. Non-Kit Parts List for Installation of C4ISR Equipment (Contd).*

ITEM NO.	NOMENCLATURE	PART NUMBER	NSN	QTY.
81.	Screw, Cap	B1821BH025C062N	5305-01-458-5397	4
82.	Screw, Cap	B1821BH025C075N	5305-00-068-0508	8
83.	Screw, Cap	B1821BH025C088N	5305-00-071-2505	7
84.	Screw, Cap	B1821BH025C100N	5305-00-225-3843	54
85.	Screw, Cap	B1821BH025C125N	5305-00-068-0509	6
86.	Screw, Cap	B1821BH025C150N	5305-00-071-2509	4
87.	Screw, Cap	B1821BH031F075N	5306-00-050-1238	2
88.	Screw, Cap	B1821BH031F100N	5305-00-051-4076	10
89.	Screw, Cap	B1821BH031F125N	5305-00-051-4078	10
90.	Screw, Cap	B1821BH031C100N	5306-00-226-4827	8
91.	Screw, Cap	B1821BH025C138N	5305-00-225-3841	8
92.	Screw, Cap	B1821BH038C150N	5305-00-725-2317	4
93.	Screw, Cap	B1821BH038C225N	5305-01-434-2947	2
94.	Screw, Cap	B1821BH038F175N	5305-00-269-3241	4
95.	Screw, Cap	B1821BH044C150N	5305-00-071-2055	2
96.	Screw, Cap	B1821BH044C125N	5305-00-071-1788	4
97.	Screw, Self-Tapping	12342499-2	5305-01-264-5809	10
98.	Screw, Self-Tapping	9421073	5305-01-162-8512	25
99.	Screw, Self-Tapping	9426241	5305-01-206-7219	9
100.	Screw, Self-Tapping	9426634	4320-00-570-6117	4
101.	Spacer	10181-5214-01	N/A	5
102.	Spacer	A3046313	5820-01-237-8096	4
103.	Spacer	92510A318	N/A	4
104.	Spacer	10705AL315C	5365-01-487-3145	4
105.	Speaker	10181-5180-01	N/A	1
106.	Strap, Tiedown	MS3367-1-0	5975-00-984-6582	A/R
107.	Terminal Board	12480570	N/A	1
108.	Terminal Board	MS27212-3-8	5940-00-950-7782	1
109.	Terminal Board Cover	12480569-1	N/A	1
110.	Terminal Board Cover	12480569-2	N/A	1
111.	Terminal Board Cover	MS18029-3S-2	5940-01-280-9304	1
112.	Terminal Link	MS25266-6N-2	6150-01-167-9267	1
113.	Terminal Lug	7728777	5940-00-983-4067	1
114.	Terminal Lug	MS20659-108	5940-00-115-2674	1
115.	Terminal Lug	MS20659-141	5940-00-113-9825	10
116.	Terminal Lug	MS20659-129	5940-00-114-1314	2
117.	Tubing, Convoluted	Z52-0013-001	N/A	1
118.	Tubing, Shrink	MS23053/4-302-0	5970-01-161-6796	A/R
119.	Washer	12338095	5310-01-208-7576	3
120.	Washer	9414920	5310-01-476-8589	2

MATERIAL REQUIRED BUT NOT INCLUDED IN KITS (Contd):*Table 4-2. Non-Kit Parts List for Installation of C4ISR Equipment (Contd).*

ITEM NO.	NOMENCLATURE	PART NUMBER	NSN	QTY.
121.	Washer	9417373	5310-01-361-1163	1
122.	Washer	MS51412-23	5310-01-333-0060	2
123.	Washer	2436161	5310-01-102-3270	69
124.	Washer	2436163	5310-01-412-4013	14
125.	Washer, Lock	120380	5310-00-543-2705	1
126.	Washer, Lock	120382	5310-00-774-7293	6
127.	Washer, Lock	MS35338-41	5310-00-045-4007	5
128.	Washer, Lock	MS35338-44	5310-00-582-5965	42
129.	Washer, Lock	MS45904-71	5310-00-947-6980	9
130.	Washer, Lock	MS45904-72	5310-00-889-2527	24
131.	Washer, Lock	131043	5310-00-013-1043	4
132.	Wingnut	MS51553-420	5310-01-384-2546	4
133.	Wire Assembly, Fuse (12V)	12480568-2	N/A	1
134.	Wire Assembly, Fuse (24V)	12480568-1	N/A	3
135.	Wire, Braided	AA59569F30T0375	6145-00-191-8402	A/R
136.	Wire, Lock	MS20995C32	9505-00-293-4208	A/R

CHAPTER 5 INSTALLATION PROCEDURES

Section I. SCOPE

This chapter provides instructions for installation of the following C4ISR equipment:

- Single Channel Ground and Airborne Radio System (SINCGARS)
- Force XXI Battle Command, Brigade-and-Below (FBCB2)
- Precision Lightweight Global Positioning System Receiver (PLGR)
- Enhanced Position Location Reporting System (EPLRS)
- HF 20 Watt Radio
- Additional terminal boards in the vehicle

When installing C4ISR equipment, be sure to read and follow instructions and illustrations carefully.

Section II. INSTALLATION OF TERMINAL BOARDS

Use the following procedure to install additional terminal boards to provide adequate power connections. Vehicles must have dual-voltage alternators installed in order to have both 12V and 24V terminal boards installed.

Section III. CAB ENCLOSURE PANEL, TERMINAL BOARD, AND COVER MODIFICATION

NOTE

- For vehicles without cab enclosure panel, begin with step 3-1 and use cab enclosure panel NSN 2510-01-413-5993.
 - For vehicles with cab enclosure panel, begin with step 3-3.
 - All dimensions are in inches.
- 3-1.** Place cab enclosure panel (3) in position. Locate, mark, and drill five 0.159-in. diameter holes marked A and B in B-beam (1) and battery box (2).
 - 3-2.** Enlarge two lower mounting holes marked A to 0.390-in. diameter, and install two inserts (4) in battery box (2).

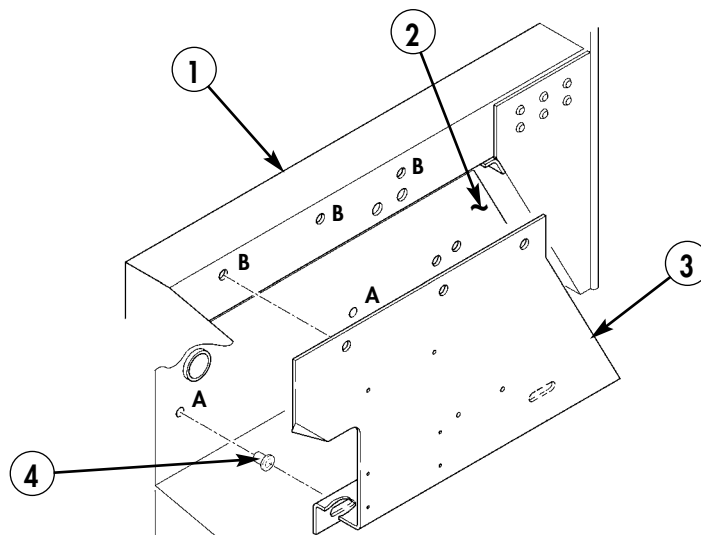

- 3. CAB ENCLOSURE PANEL – 12447141 – QTY. 1**
- 4. INSERT – 12446871-2 – QTY. 2**

Figure 5-1.

NOTE

- Do not install cab enclosure panel.
- Use figures 5-2 and 5-3 to identify cab enclosure panel that is being modified.

- 3-3.** Locate, mark, and drill three 0.156-in. diameter holes marked A in cab enclosure panel (3) as shown in figures 5-2 or 5-3.
- 3-4.** Locate, mark, and drill two 0.156-in. diameter holes marked C in cab enclosure panel (3) as shown in figures 5-2 or 5-3.

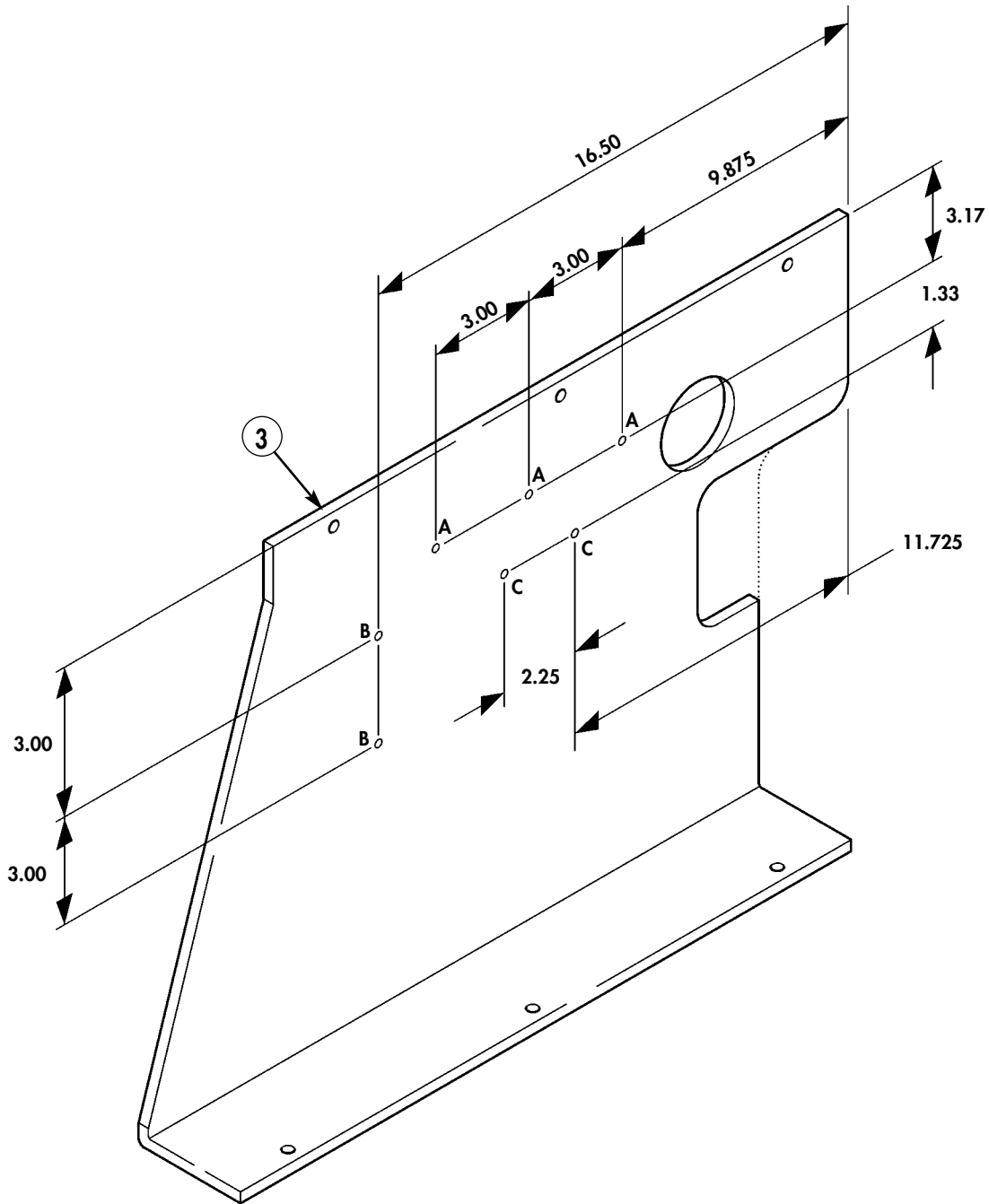

Figure 5-2.

3-5. Locate, mark, and drill two 0.196-in. diameter holes marked B in cab enclosure panel (3) as shown in figures 5-2 or 5-3.

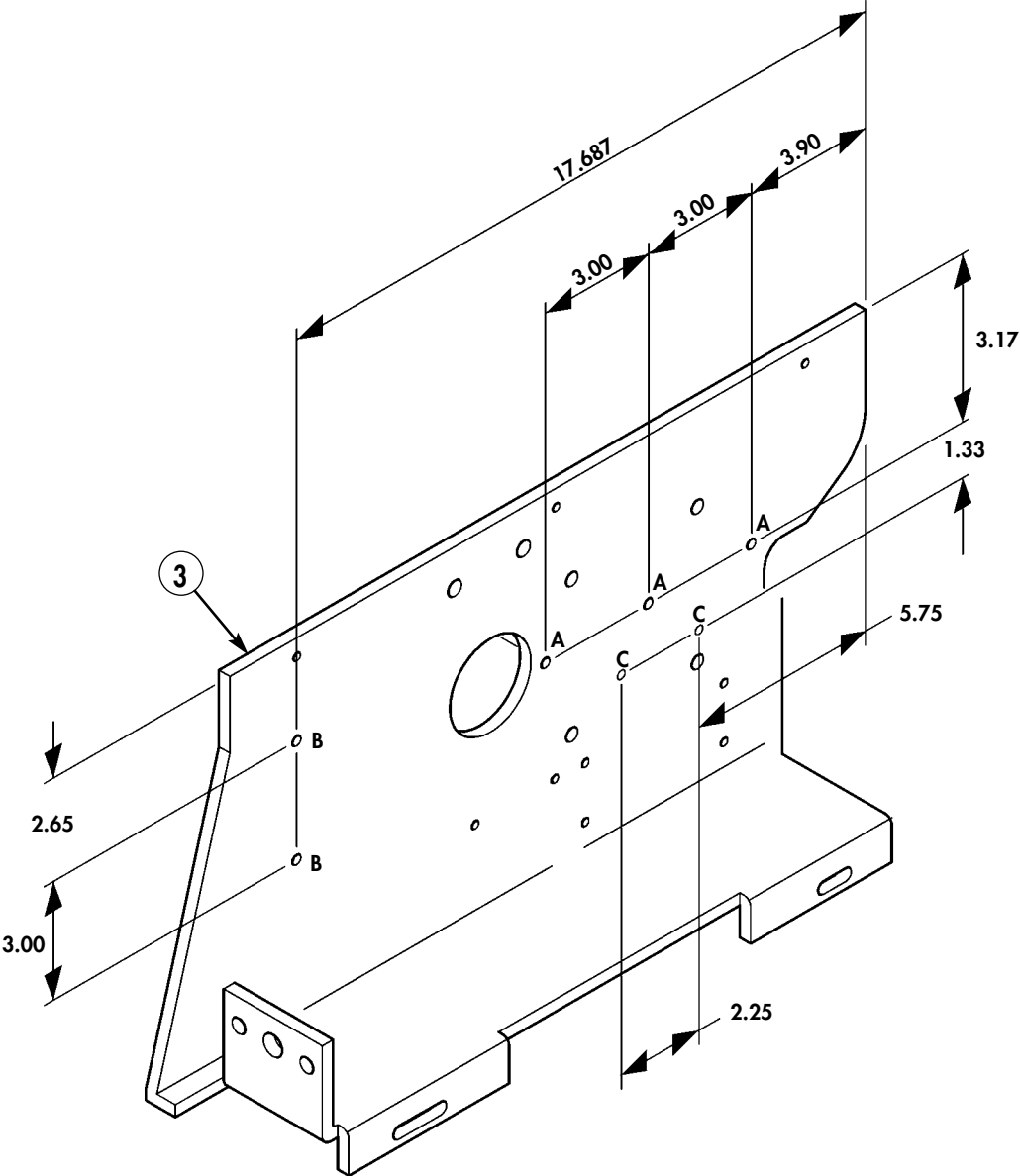

Figure 5-3.

CAUTION

Do not cut raised sections of terminal board. Terminal board is not usable if cut on raised section.

- 3-6. Measure and cut terminal board (5) in two places (6). Remove burrs and sharp edges.
- 3-7. Install five nut sleeves (9) in terminal board covers (7), (8), and (10), and secure with five snaprings (11).

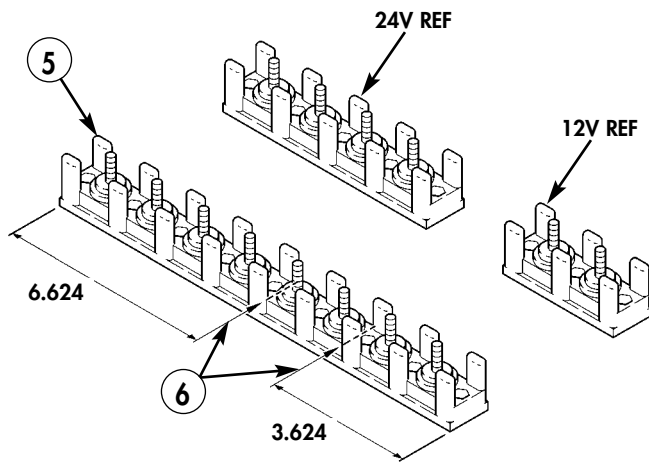

Figure 5-4.

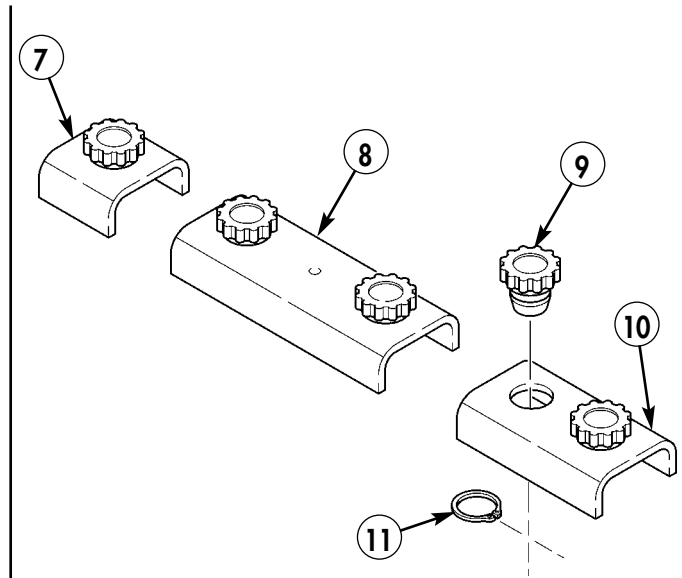

Figure 5-5.

- 5. TERMINAL BOARD – MS27212-3-8 – QTY. 1
- 7. TERMINAL BOARD COVER – 12480569-1 – QTY. 1
- 8. TERMINAL BOARD COVER – 12480569-2 – QTY. 1
- 10. TERMINAL BOARD COVER – MS18029-3S-2 – QTY. 1

Section IV. B-BEAM PREPARATION

Locate, mark, and drill four 0.159-in. diameter holes (2) in B-beam (1).

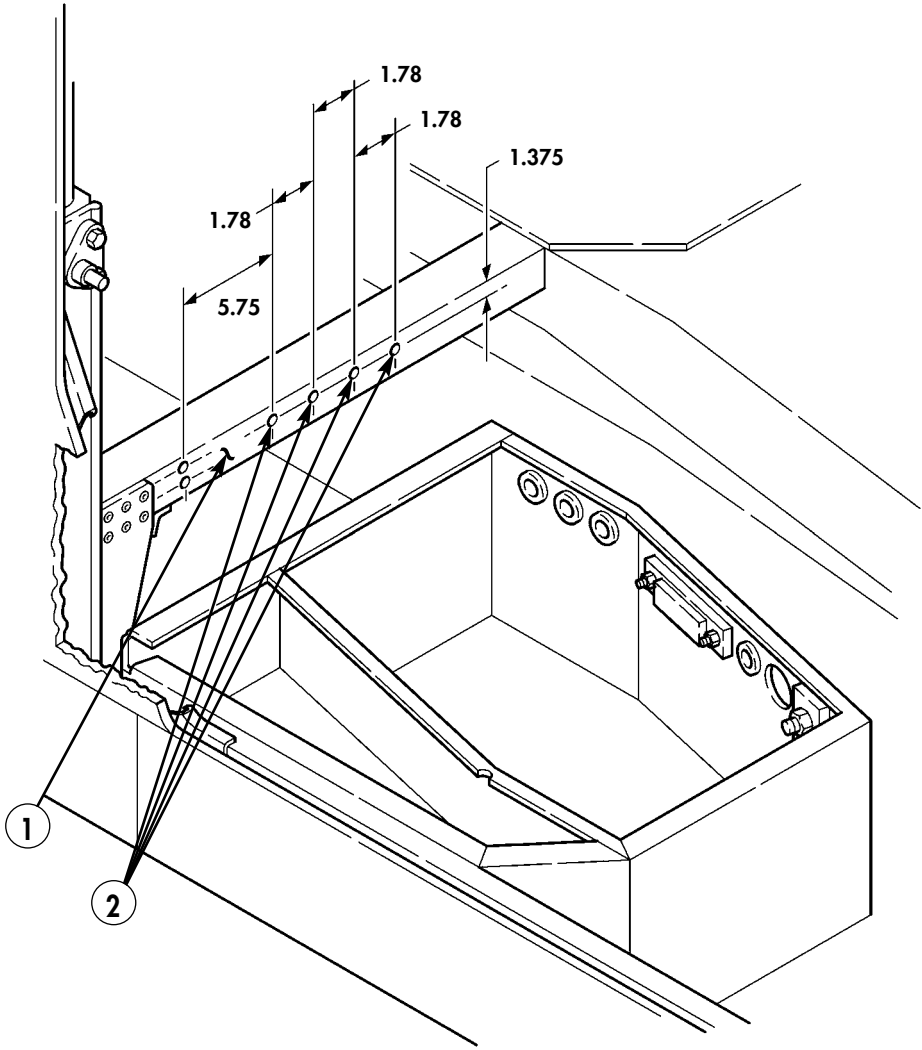
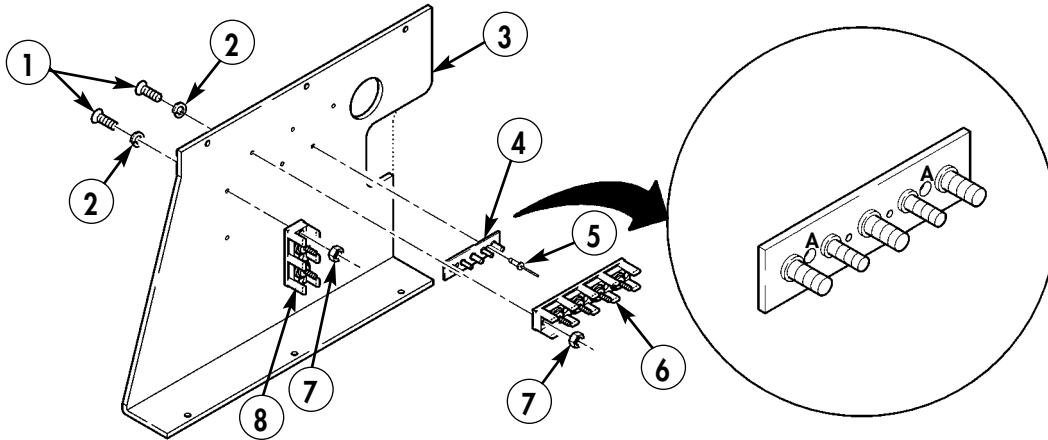

Figure 5-6.

Section V. ASSEMBLY OF CAB ENCLOSURE PANEL

- 5-1. Install 12V terminal board (8) on cab enclosure panel (3) with two screws (1), lockwashers (2), and nuts (7).
- 5-2. Install 24V terminal board (6) on cab enclosure panel (3) with three screws (1), lockwashers (2), and nuts (7).
- 5-3. Enlarge two holes marked A in terminal board (4) to 0.196 in., and secure terminal board (4) to cab enclosure panel (3) with two rivets (5).



- 1. SCREW – MS35206-230 – QTY. 5
- 2. LOCKWASHER – MS35338-41 – QTY. 5
- 4. TERMINAL BOARD – 12480570 – QTY. 1
- 5. BLIND RIVET – 12339355-1 – QTY. 2
- 7. NUT – MS35649-63 – QTY. 5

Figure 5-7.

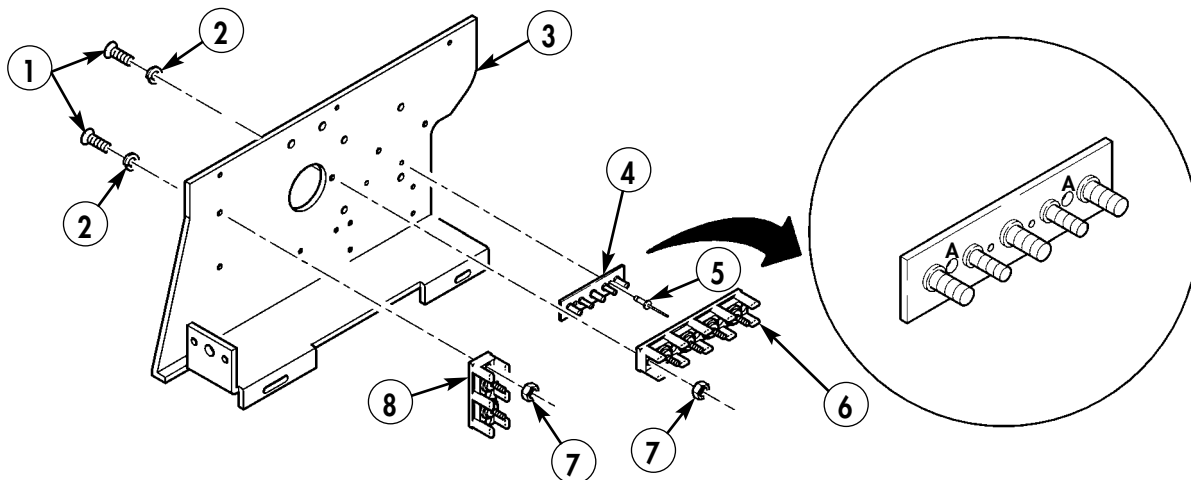

Figure 5-8.

Section VI. FINAL ASSEMBLY, TERMINAL BOARD WIRING, AND TERMINAL LINK

NOTE

- Refer to figure 5-9 for wiring overview.
 - Perform steps 6-1 and 6-2 if hole and grommet do not exist in battery box.
- 6-1.** Locate, mark, and drill one 2.00-in. diameter hole (6) in upper right corner of rear wall of battery box.
 - 6-2.** Install grommet (7) in hole (6).
 - 6-3.** Secure terminal link (2) and fuse wire (3) to 12V terminal board (1) with two locknuts (4). Install cover (5) on 12V terminal board (1).
 - 6-4.** Route wire (8) through battery box hole (6).

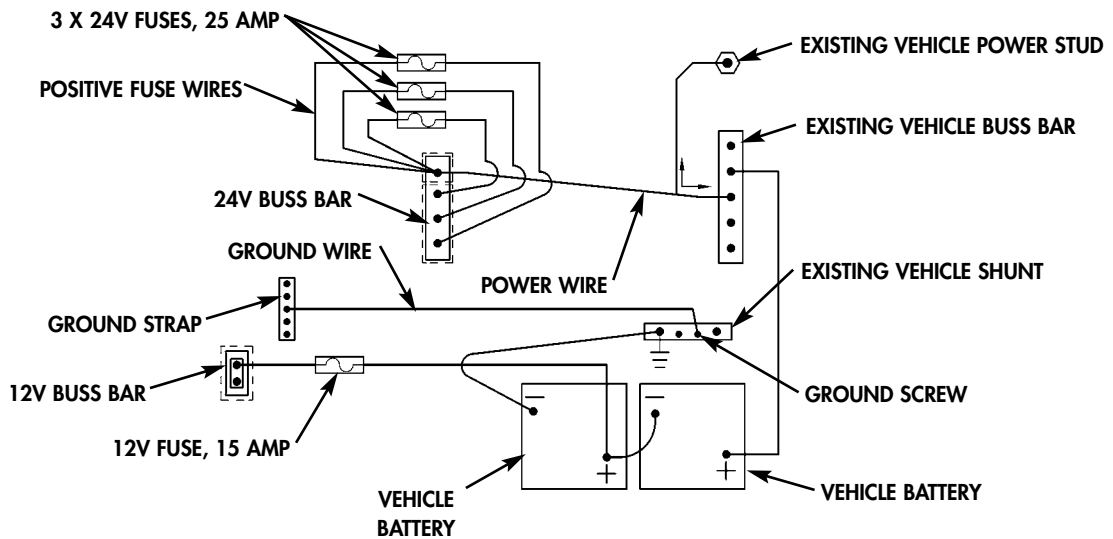
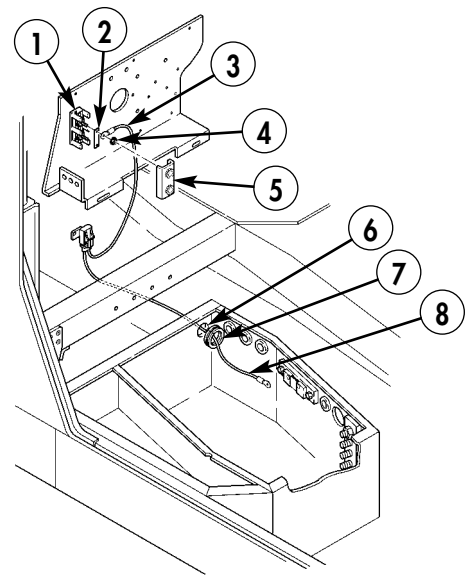

Figure 5-9.



- 2. TERMINAL LINK – MS25226-6N-2 – QTY. 1**
- 3. FUSE WIRE ASSEMBLY (12V) – 12480568-2 – QTY. 1**
- 4. LOCKNUT – 271175 – QTY. 2**
- 7. GROMMET – 2400 – QTY. 1**

Figure 5-10.

- 6-5. Connect wire (8) to existing positive 12V battery terminal end (10) with existing screw (9) and nut (11).

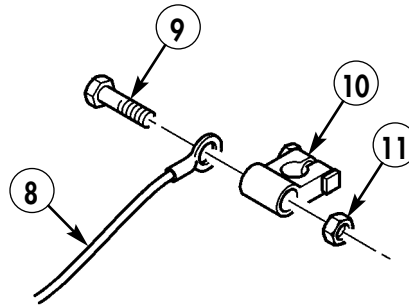
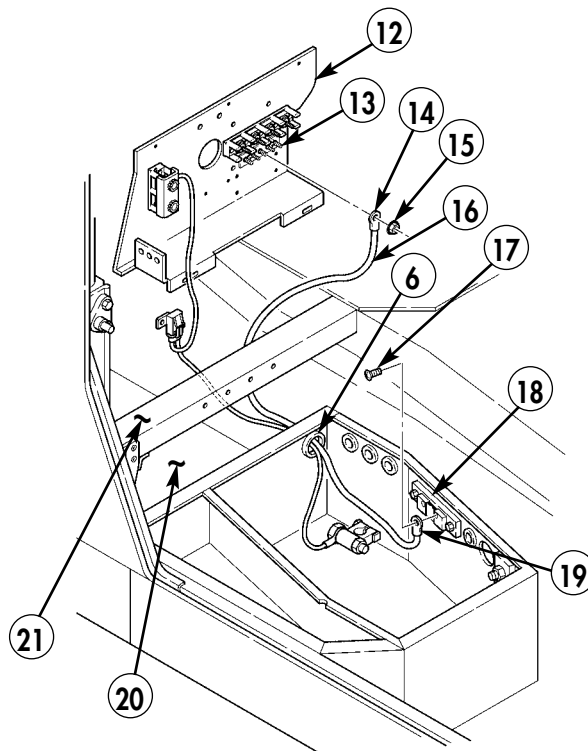

Figure 5-11.

- 6-6. Position cab enclosure panel (12) in rear floor pan (20) and rear of B-beam (21). Do not secure cab enclosure panel (12) at this time.
- 6-7. Route ground cable (16) through battery box hole (6).
- 6-8. Secure terminal lug (14) on center terminal of terminal board (13) with nut (15), and secure terminal lug (19) on shunt (18) with existing screw (17).
- 6-9. Install four additional nuts (15) on terminal board (13).



- 15. PLAIN-ASSEMBLED NUT – 271169 – QTY. 5
- 16. GROUND CABLE ASSEMBLY – 12480567-1 – QTY. 1

Figure 5-12.

- 6-10.** Route 24V power cable (27) through hole (6) and install 24V power cable terminal lug (23) on inboard stud (22) of terminal board (28). Do not secure 24V power cable terminal lug (23) at this time.
- 6-11.** Secure three fuse wires (25) and 24V power cable terminal lug (23) to inboard terminal board stud (22) with locknut (26).
- 6-12.** Secure three remaining fuse wires (24) to corresponding studs on 24V terminal board (28) with three locknuts (26).

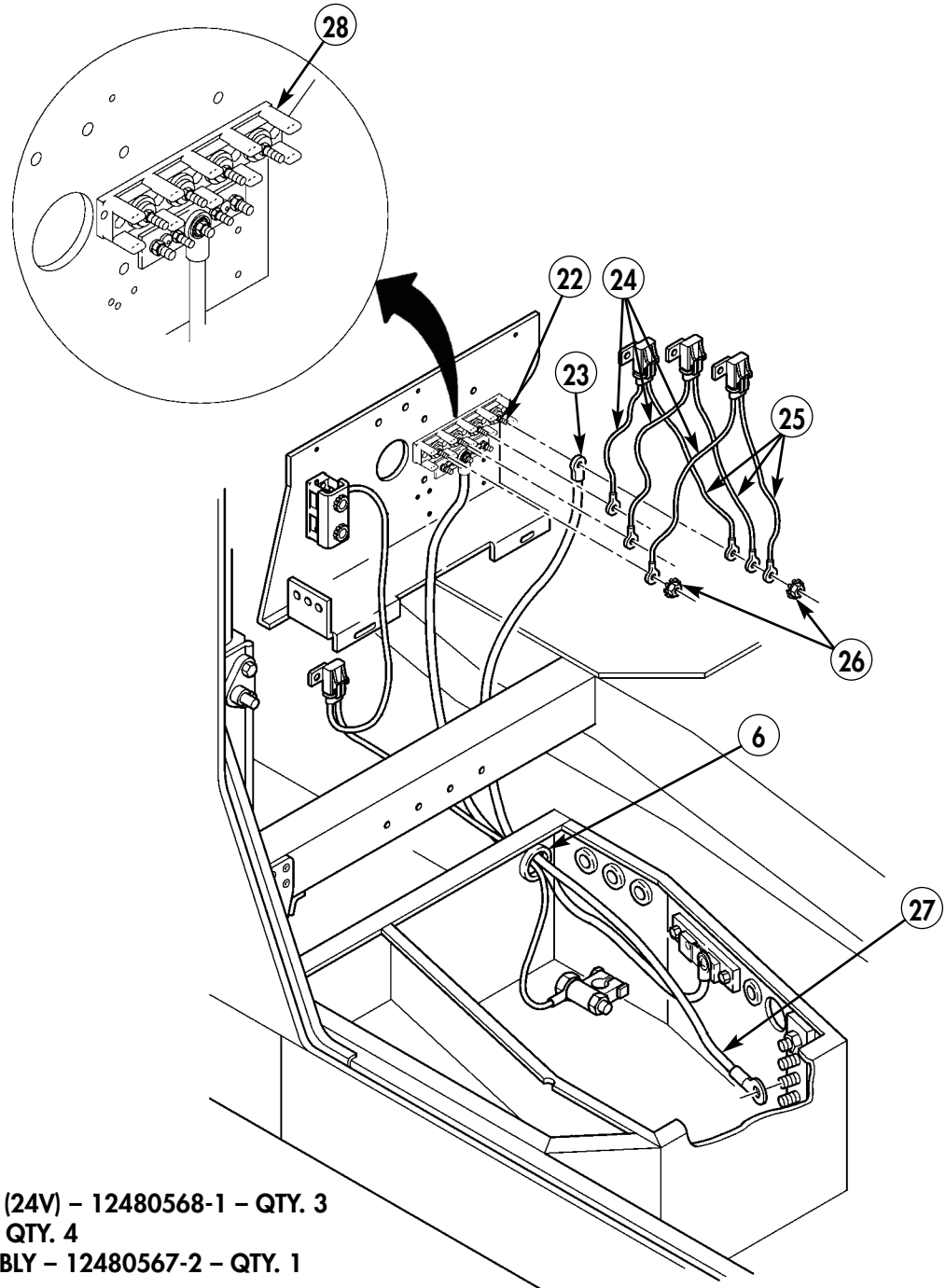

- 24. FUSE WIRE ASSEMBLY (24V) - 12480568-1 - QTY. 3**
26. LOCKNUT - 271175 - QTY. 4
27. POWER CABLE ASSEMBLY - 12480567-2 - QTY. 1

Figure 5-13.

NOTE

For vehicles with new cab enclosure panel, begin with step 6-14.

- 6-13.** Install cab enclosure panel (12). (Refer to TM 9-2320-280-20.)
- 6-14.** Secure cab enclosure panel (12) to B-beam (21) with three self-tapping screws (29).
- 6-15.** Secure cab enclosure panel (12) to battery box (33) with two capscrews (30), lockwashers (31), and washers (32).

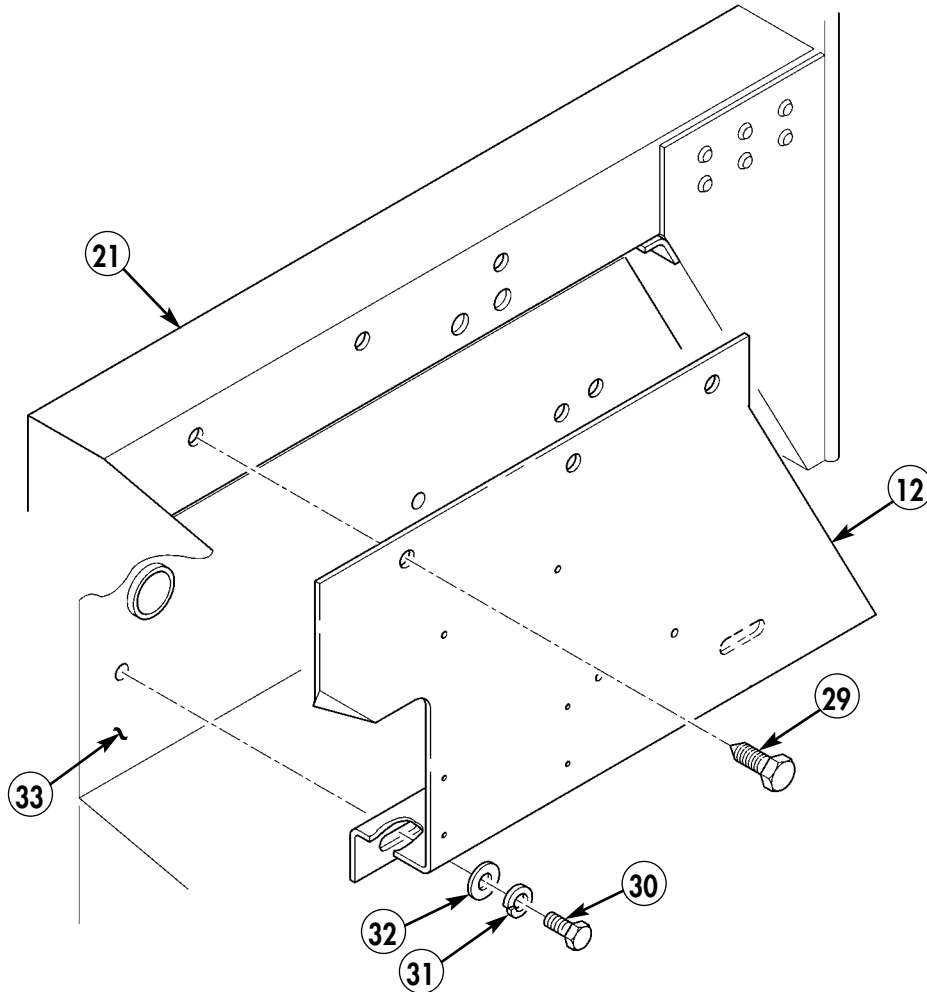

- 29. SELF-TAPPING SCREW – 12342499-2 – QTY. 3**
- 30. CAPSCREW – B1821BH025C075N – QTY. 2**
- 31. LOCKWASHER – MS35338-48 – QTY. 2**
- 32. FLAT WASHER – MS51412-23 – QTY. 2**

Figure 5-14.

- 6-16.** Secure three 24V fusewire assemblies (24) and one 12V fusewire assembly (3) to B-beam (21) with four self-tapping screws (35).

NOTE

For models equipped with power stud, perform step 6-17.
Otherwise, proceed to step 6-18.

- 6-17.** Secure 24V terminal board power wire terminal lug (27) to power stud (39) with lockwasher (37) and existing nut (38).
- 6-18.** Secure 24V terminal board power wire terminal lug (27) to terminal board (36) with lockwasher (37) and existing nut (38).
- 6-19.** Install decal (34) on B-beam (21).
- 6-20.** If previously removed, install right-hand rear fixed door. (Refer to TM 9-2320-280-20.)
- 6-21.** Install batteries. (Refer to TM 9-2320-280-20.)



- 34. DECAL – 12339060 – QTY. 1**
35. SELF-TAPPING SCREW – 12342499-2 – QTY. 4
37. LOCKWASHER – MS35338-48 – QTY. 1

Figure 5-15.

Section VII. INTEGRATED RACK INSTALLATION

NOTE

Perform step 7-1 only if MT-6353/VRC mounting base is to be installed.

- 7-1. Remove two inserts (2) from bottom of integrated rack (1).

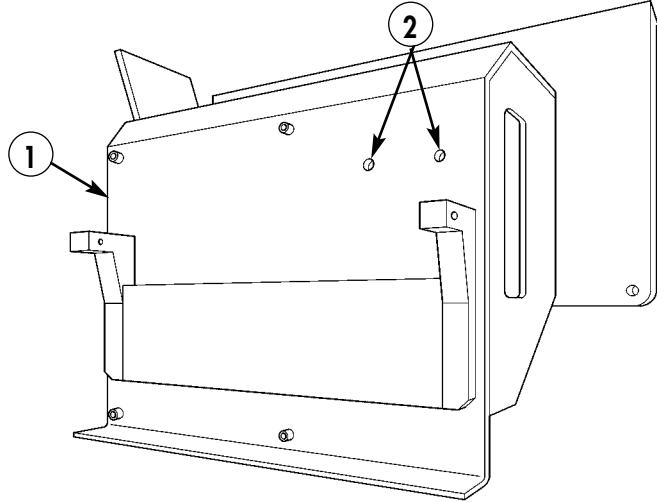

1. RACK, INTEGRATED – A3276903 – QTY. 1

Figure 5-16.

- 7-2. Using integrated rack (1) as template, locate, mark, and drill one 0.390-in. diameter hole (4) in dash (6).
- 7-3. Remove paint from vicinity of hole (4) and two existing inserts (5).
- 7-4. Install insert (3) in hole (4).
- 7-5. Apply anti-seize compound to vicinity of inserts (3) and (5) as required.

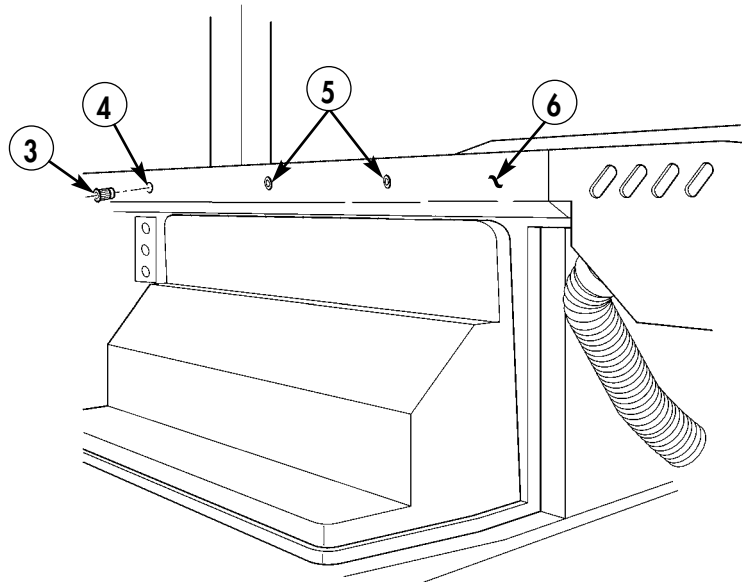

3. INSERT – 12446871-2 – QTY. 1

Figure 5-17.

- 7-6. Remove paint from vicinity of three mounting slots (7) on integrated rack (1).
- 7-7. Apply anti-seize compound to vicinity of three mounting slots (7) on integrated rack (1) as required.

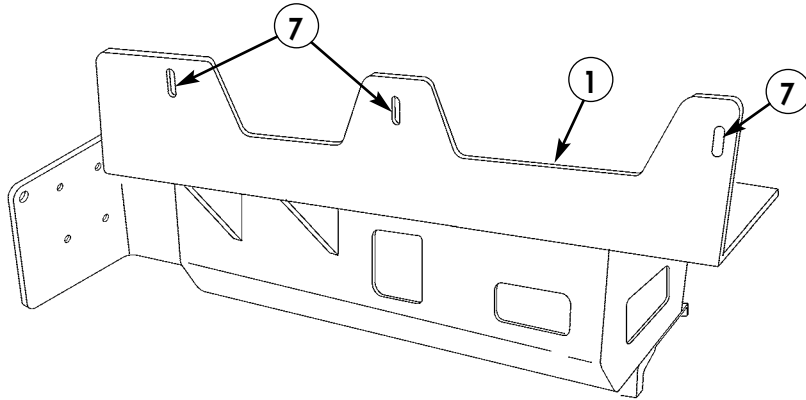
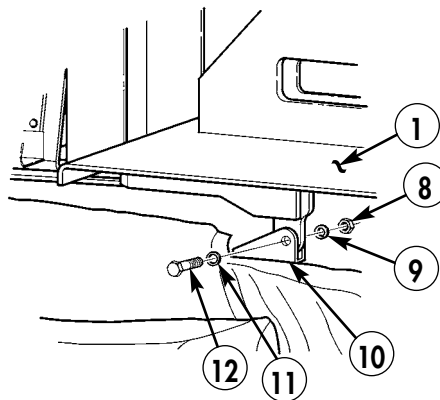

Figure 5-18.

NOTE

Do not install mounting hardware on top of integrated rack at this time. Not installing this hardware leaves the integrated rack free to pivot to assist in routing of cabling. Secure rack only after all cabling has been routed.

- 7-8. Mount integrated rack (1) to existing radio rack mount (10) using screw (12), washer (11), lockwasher (9), and nut (8). Repeat for opposite side. Do not tighten screws.



8. NUT – MS35649-2382 – QTY. 2
 9. LOCKWASHER – MS35338-46 – QTY. 2
 11. WASHER – 2436163 – QTY. 2
 12. CAPSCREW – B1821BH038C225N – QTY. 2

Figure 5-19.

Section VIII. INSTALLATION OF SINGARS MOUNTING TRAY AND AMP GUARD

- 8-1. Remove paint from vicinity of four mounting holes (6) on integrated rack (7) and vicinity of four mounting holes (5) on bottom of mounting base (4).
- 8-2. Apply anti-seize compound to vicinity of four mounting holes (6) on integrated rack (7) and four mounting holes (5) on mounting base (4) as required.

NOTE

Two lockwashers and one nut are used on driver-side screws only.

- 8-3. Install MT-6352/VRC mounting base (4) and amp guard (9) on integrated rack (7) with two capscrews (2), four lockwashers (1), and two nuts (8). Secure MT-6352/VRC mounting base (4) to integrated rack (7) with two capscrews (3) and two lockwashers (1).
- 8-4. Place warning decal (10) on amp guard (9).

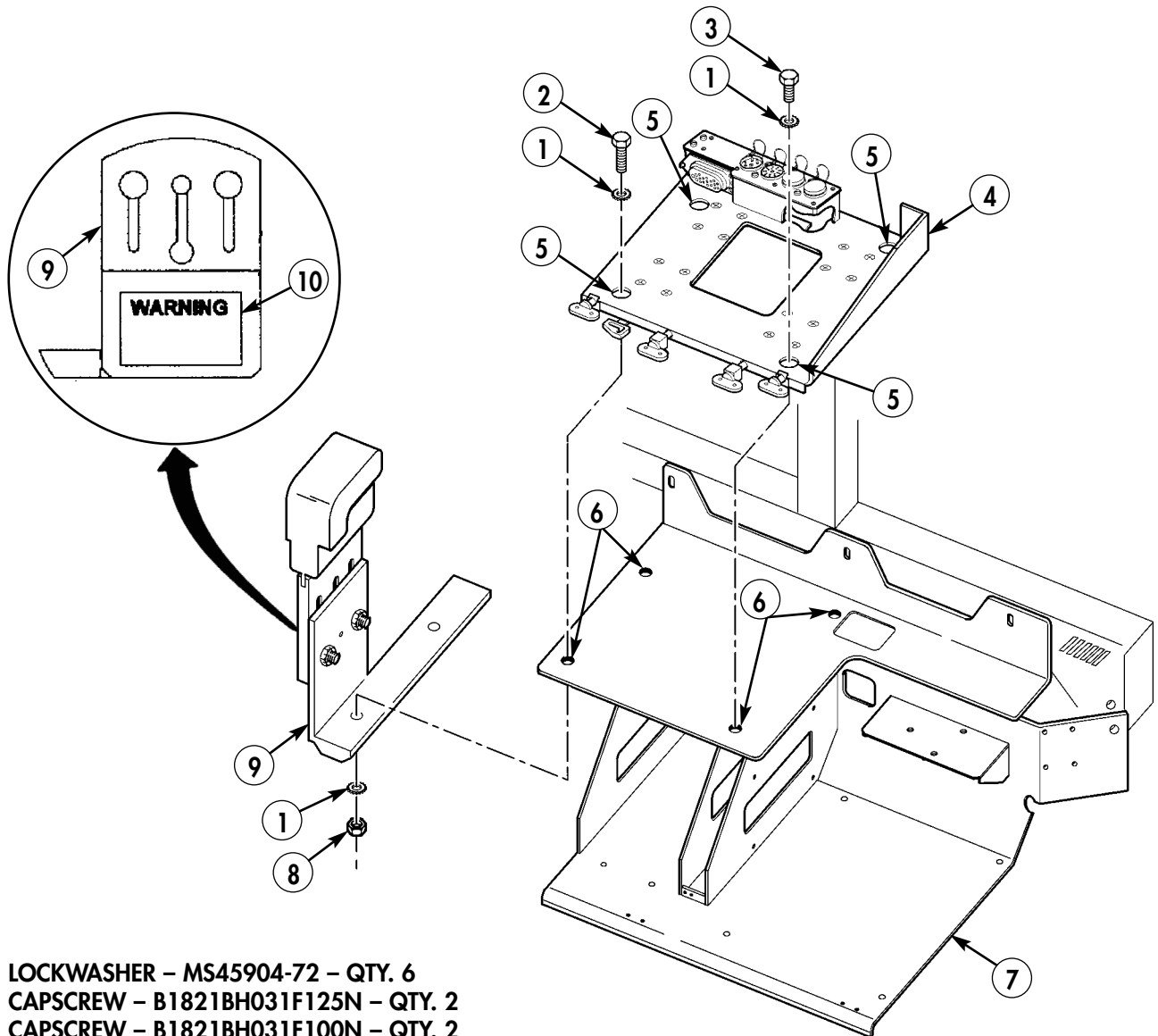

- 1. LOCKWASHER – MS45904-72 – QTY. 6
- 2. CAPSCREW – B1821BH031F125N – QTY. 2
- 3. CAPSCREW – B1821BH031F100N – QTY. 2
- 4. MOUNTING BASE, MT-6352/VRC – A3013367-1 – QTY. 1
- 8. NUT – MS51968-5 – QTY. 2
- 9. AMP GUARD – 872842-1 – QTY. 1
- 10. DECAL – 861868-2 – QTY. 1

Figure 5-20.

Section IX. POWER AMPLIFIER INSTALLATION

NOTE

Perform this procedure only if SINCGARS model AN/VRC-92F is to be installed.

- 9-1. Remove paint from vicinity of four mounting areas (2) on MT-6353/VRC mounting base (1) and apply anti-seize compound as required.

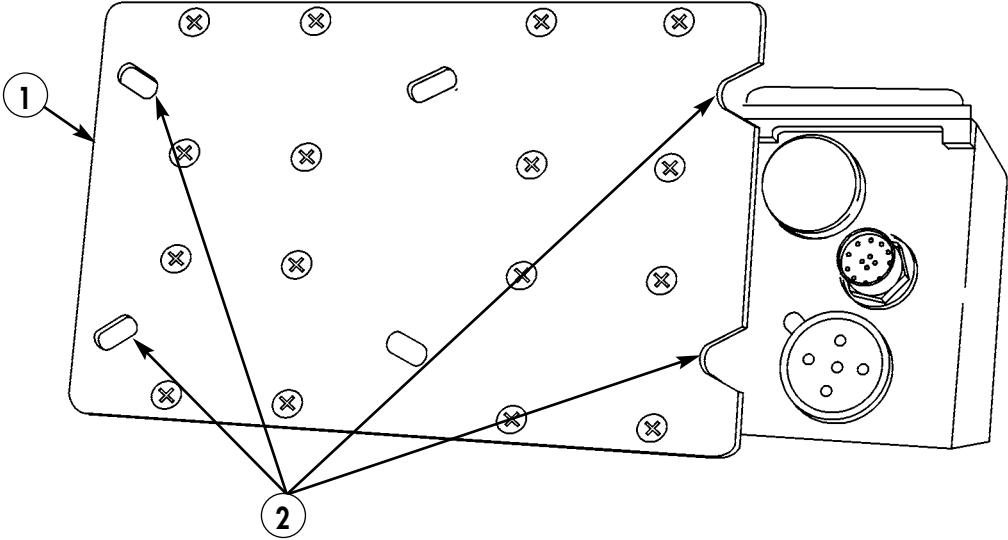

1. MOUNTING BASE, MT-6353/VRC – A3014053-1 – QTY. 1

Figure 5-21.

- 9-2. Remove paint from vicinity of four mounting holes (4) on integrated rack (3) and apply anti-seize compound as required.

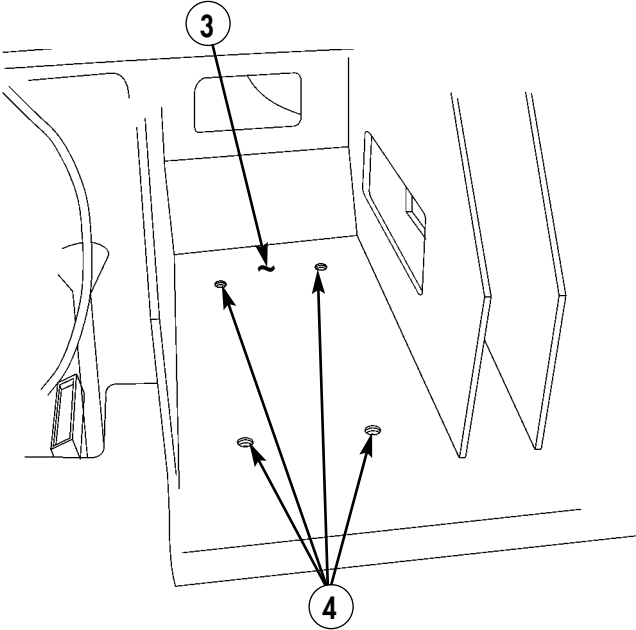
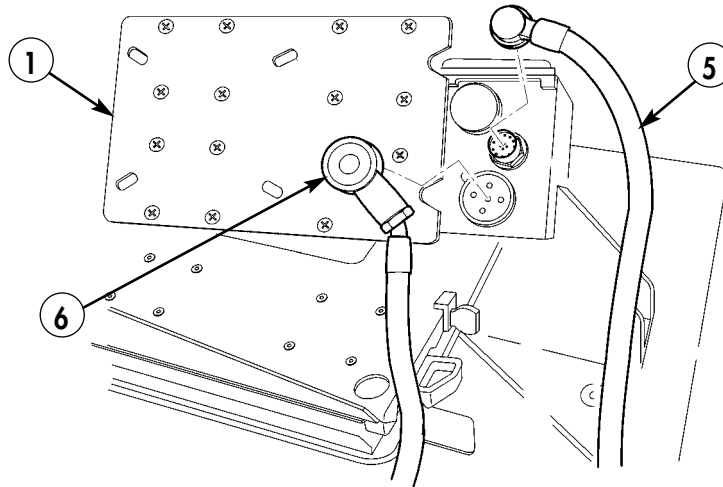

Figure 5-22.

- 9-3. Attach control cable (5) to MT-6353/VRC mounting base (1).
- 9-4. Attach power cable (6) to MT-6353/VRC mounting base (1).



- 5. CONTROL CABLE – A3014037-4 – QTY. 1
- 6. POWER CABLE – A3014040-9 – QTY. 1

Figure 5-23.

NOTE

Ensure control cable and power cable are routed through hole in back of integrated rack before installing MT-6353/VRC mounting base. Refer to chapter 5, section XIII.

- 9-5. Attach MT-6353/VRC mounting base (1) to integrated rack (3) with two capscrews (9) and (10), six lockwashers (8), and nut strip (7).

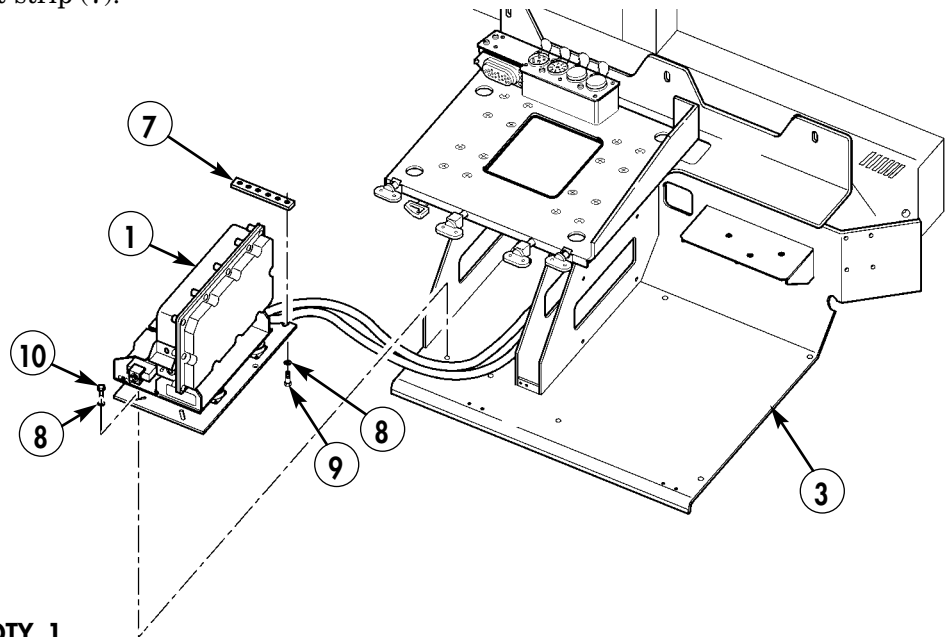

- 7. NUT STRIP – A3014064-1 – QTY. 1
- 8. LOCKWASHER – MS45904-72 – QTY. 6
- 9. CAPSCREW – B1821BH031F125N – QTY. 2
- 10. CAPSCREW – B1821BH031F075N – QTY. 2

Figure 5-24.

Section X. FCB2 COMPONENTS INSTALLATION

NOTE

SINGGARS model AN/VRC-92F shown.

- 10-1. Remove paint from vicinity of four holes (8) on integrated rack (7) and on both sides from vicinity of four holes (12) on CPU isolation kit (4). Apply anti-seize compound as required.
- 10-2. Install CPU isolation kit (4) on integrated rack (7) with three capscrews (3), washers (2), and lockwashers (1), leaving open holes (8) and (12).
- 10-3. Install CPU (6) on CPU isolation kit (4) with two existing fastener guards (5).
- 10-4. Fabricate ground strap (11) from 8.00-in. length of braided wire and two terminal lugs.
- 10-5. Install ground strap (11) on CPU ground stud (16) with existing washer (13), lockwasher (14), and wingnut (15).
- 10-6. Install ground strap (11) on CPU isolation kit (4) and integrated rack (7) with capscREW (9), washer (2), and two lockwashers (10).

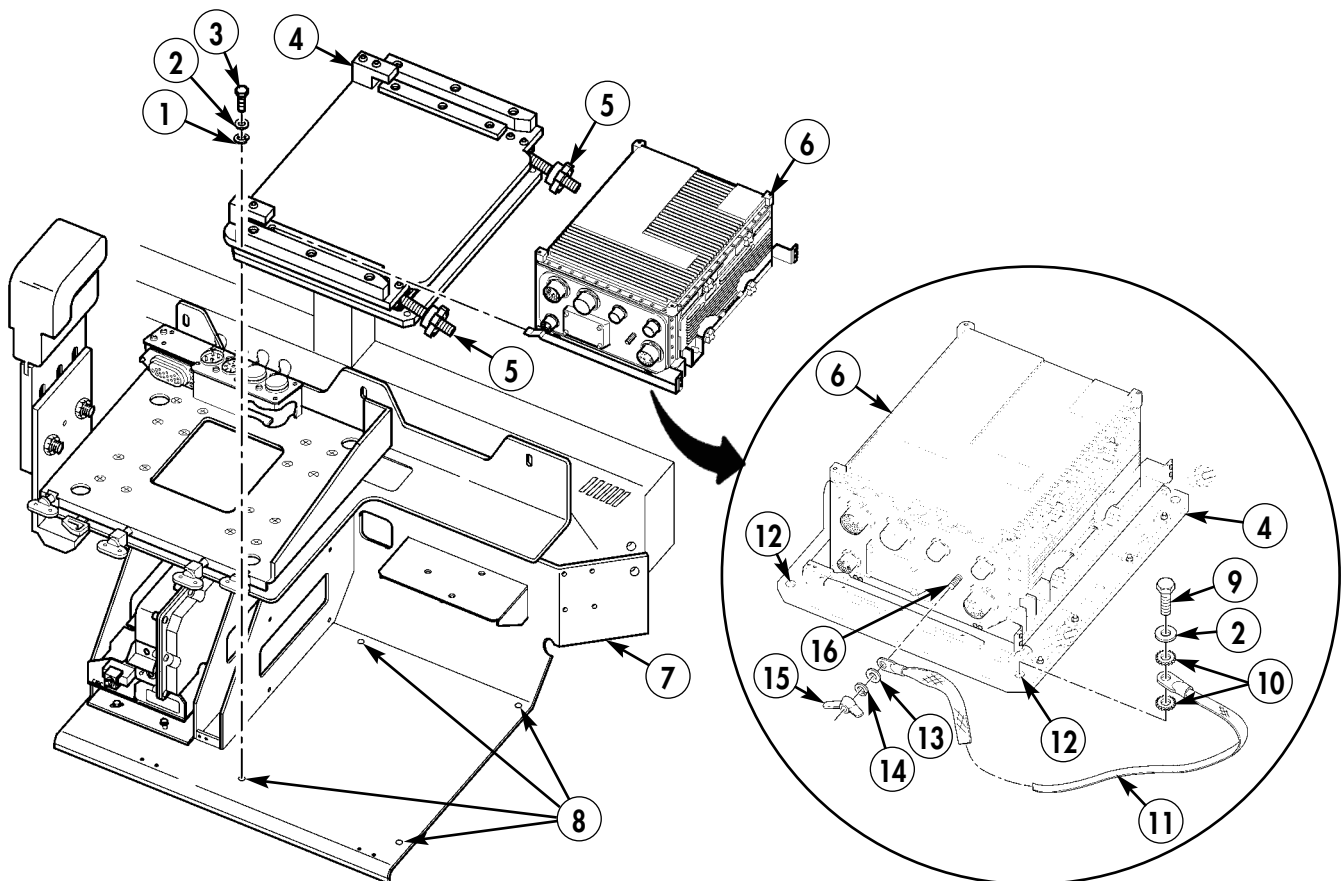

1. LOCKWASHER – MS35338-44 – QTY. 3
2. WASHER – 2436161 – QTY. 4
3. CAPSCREW – B1821BH025C100N – QTY. 3
4. CPU ISOLATION KIT – 872826-2 – QTY. 1
6. CPU – 881292-1 – QTY. 1
9. CAPSCREW – B1821BH025C125N – QTY. 1
10. LOCKWASHER – MS45904-68 – QTY. 2
11. CPU GROUND STRAP
 - BRAIDED WIRE – AA59569F30T0375 – QTY. A/R
 - TERMINAL LUG – MS20659-141 – QTY. 2

Figure 5-25.

NOTE

SINGGARS model AN/VRC-92F shown.

- 10-7. Install Ramball mount (25) on integrated rack (7) with two screws (24), screw (3), lockwasher (1), lanyard (17), washer (28), three lockwashers (1), and nuts (27).
- 10-8. Install display isolation kit (21) on display lock assembly (20) with four bolts (29), spacers (18), lanyard (17), and four wingnuts (19).
- 10-9. Install display unit (23) on display isolation kit (21) with four screws (22).
- 10-10. Install display lock assembly (20) on Ramball mount (25).
- 10-11. Fabricate display ground strap (26) from 8-in. length of braided wire and two terminal lugs.

NOTE

Remove paint from vicinity of integrated rack mounting hole before performing step 10-12. Apply anti-seize compound as required. Ground strap will be installed on integrated rack only when integrated rack is fully secured in vehicle.

- 10-12. Install display ground strap (26) on display ground stud (32) with existing lockwasher (31) and wingnut (30).

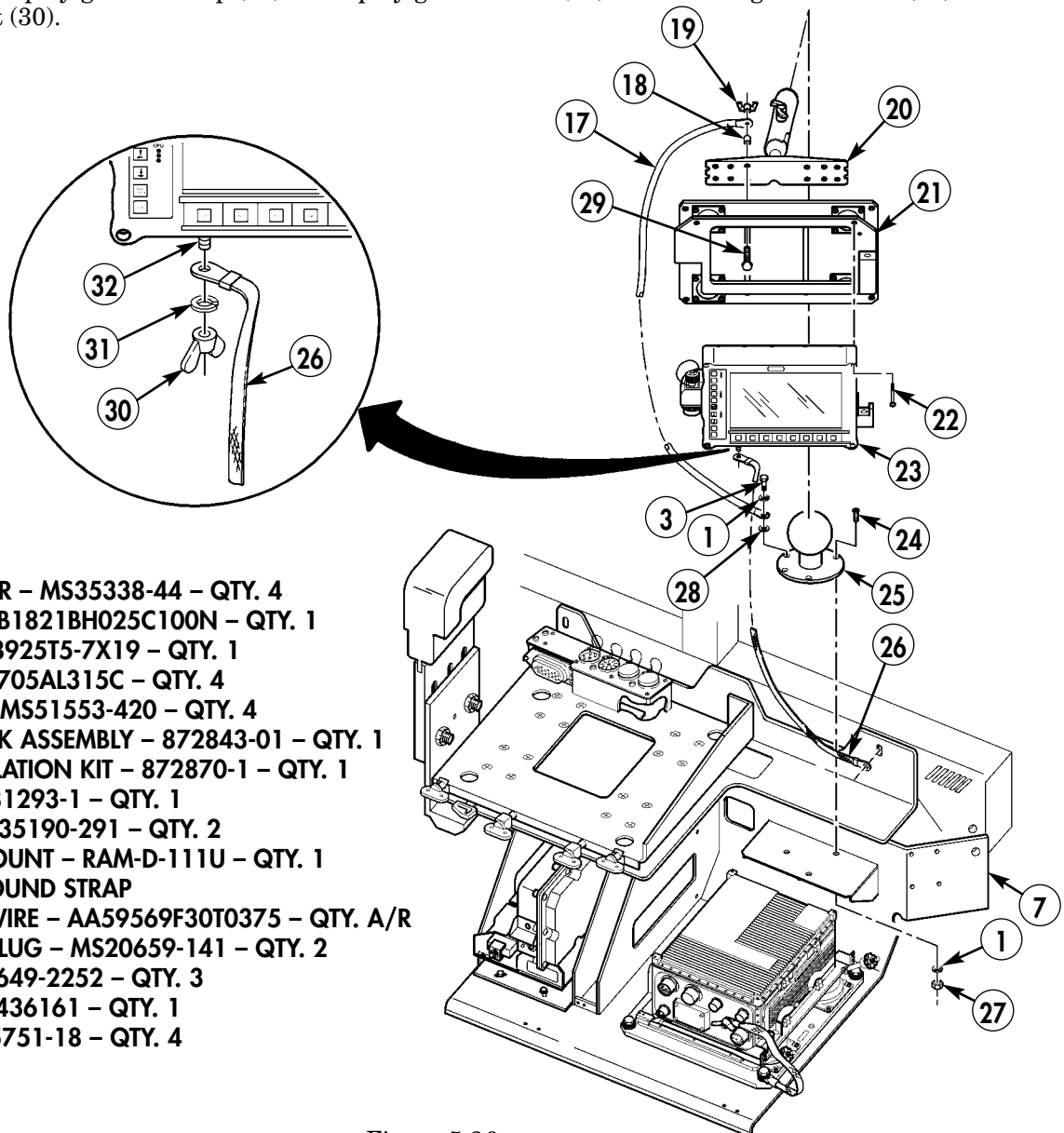

- 1. LOCKWASHER - MS35338-44 - QTY. 4
- 3. CAPSCREW B1821BH025C100N - QTY. 1
- 17. LANYARD - 8925T5-7X19 - QTY. 1
- 18. SPACER - 10705AL315C - QTY. 4
- 19. WINGNUT - MS51553-420 - QTY. 4
- 20. DISPLAY LOCK ASSEMBLY - 872843-01 - QTY. 1
- 21. DISPLAY ISOLATION KIT - 872870-1 - QTY. 1
- 23. DISPLAY - 881293-1 - QTY. 1
- 24. SCREW - MS35190-291 - QTY. 2
- 25. RAMBALL MOUNT - RAM-D-111U - QTY. 1
- 26. DISPLAY GROUND STRAP
 - BRAIDED WIRE - AA59569F30T0375 - QTY. A/R
 - TERMINAL LUG - MS20659-141 - QTY. 2
- 27. NUT - MS35649-2252 - QTY. 3
- 28. WASHER - 2436161 - QTY. 1
- 29. BOLT - MS35751-18 - QTY. 4

Figure 5-26.

Section XI. LOUDSPEAKER INSTALLATION

NOTE

- Ensure all mounting holes are on the flat surface of cargo floor raised ribs.
- Perform steps 11-1 through 11-3 for left-side speaker installation.

11-1. Using speaker mounting plate (1) as template, locate, mark, and drill four 0.201-in. diameter holes (3) in cargo floor (2).

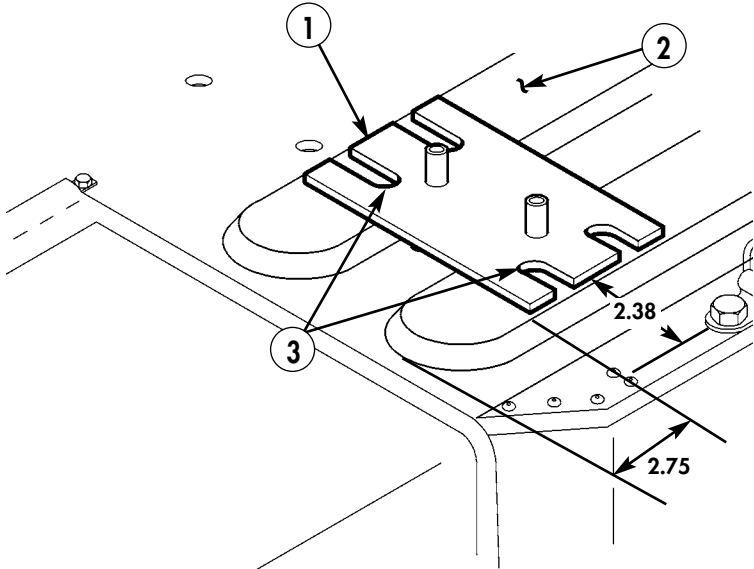

1. MOUNTING PLATE – A3014550-1 – QTY. 1

Figure 5-27.

11-2. Attach speaker mounting plate (1) to cargo floor (2) with four self-tapping screws (4).

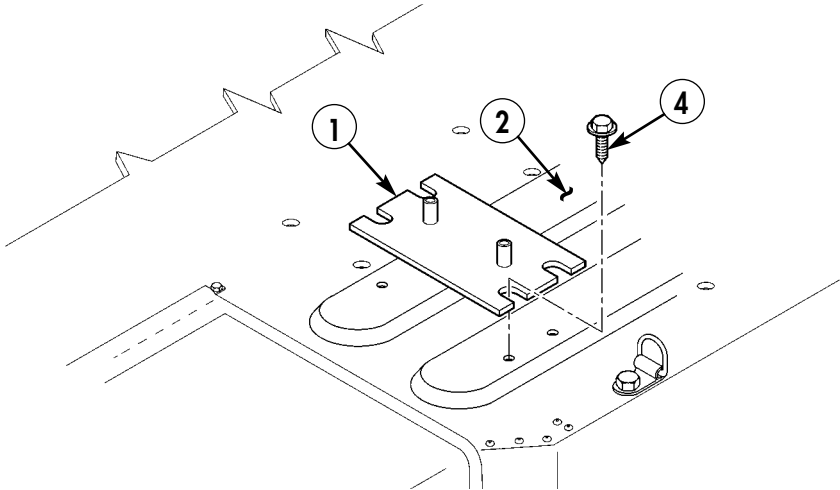

4. SELF-TAPPING SCREW – 9426241 – QTY. 4

Figure 5-28.

- 11-3. Attach loudspeaker (5) to speaker mounting plate (1) with two existing externally-relieved body screws (6).

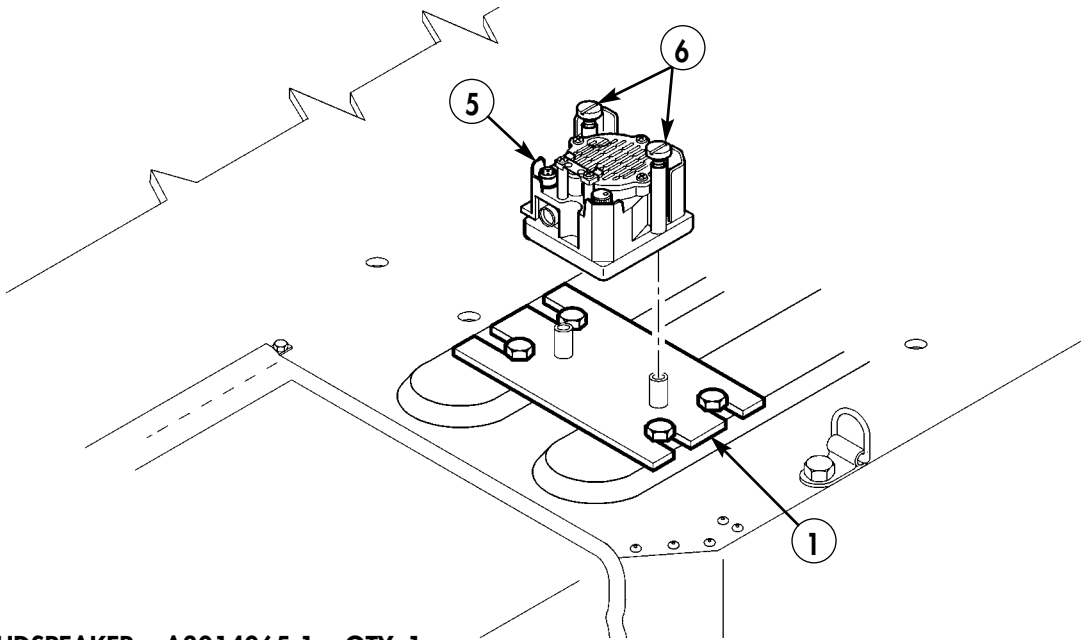

5. LOUDSPEAKER – A3014065-1 – QTY. 1

Figure 5-29.

NOTE

Perform steps 11-4 through 11-6 for right side speaker installation.

- 11-4. Using speaker mounting plate (1) as template, locate, mark, and drill four 0.201-in. diameter holes (7) in cargo floor (2).

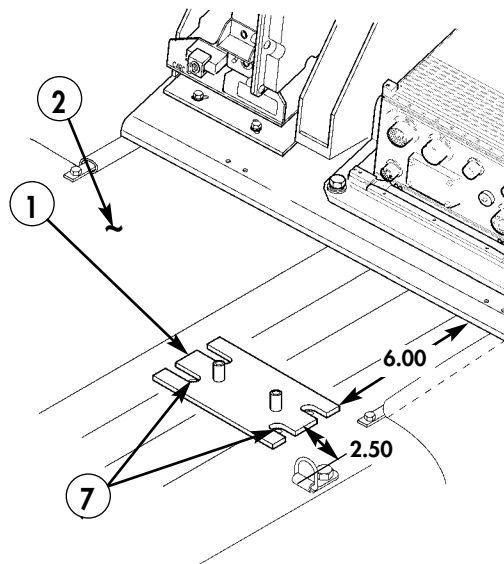

1. MOUNTING PLATE – A3014550-1 – QTY. 1

Figure 5-30.

11-5. Attach speaker mounting plate (1) to cargo floor (2) with four self-tapping screws (4).

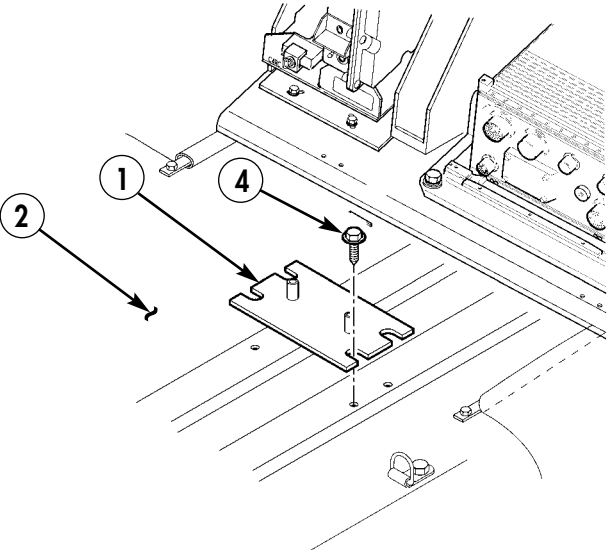

4. SELF-TAPPING SCREW – 9426241 – QTY. 4

Figure 5-31.

11-6. Attach loudspeaker (5) to speaker mounting plate (1) with two existing externally-relieved body screws (6).

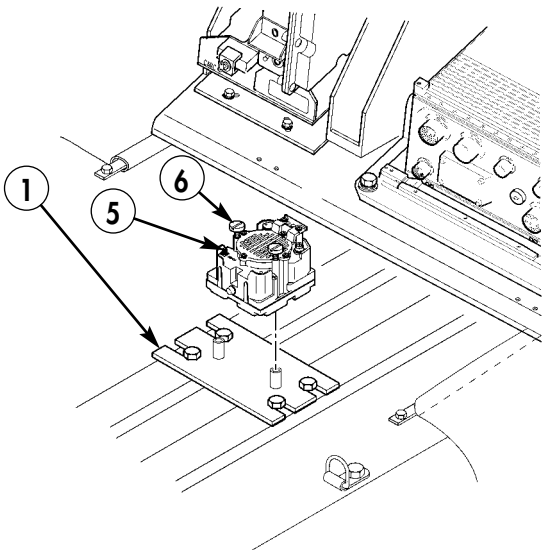

5. LOUDSPEAKER – A3014065-1 – QTY. 1

Figure 5-32.

Section XII. HF 20 WATT RADIO MOUNT INSTALLATION

- 12-1. Using cover (2) as template, locate and mark position for enclosure (2) on wheelwell (1)
- 12-2. Locate and mark position for hole.

NOTE

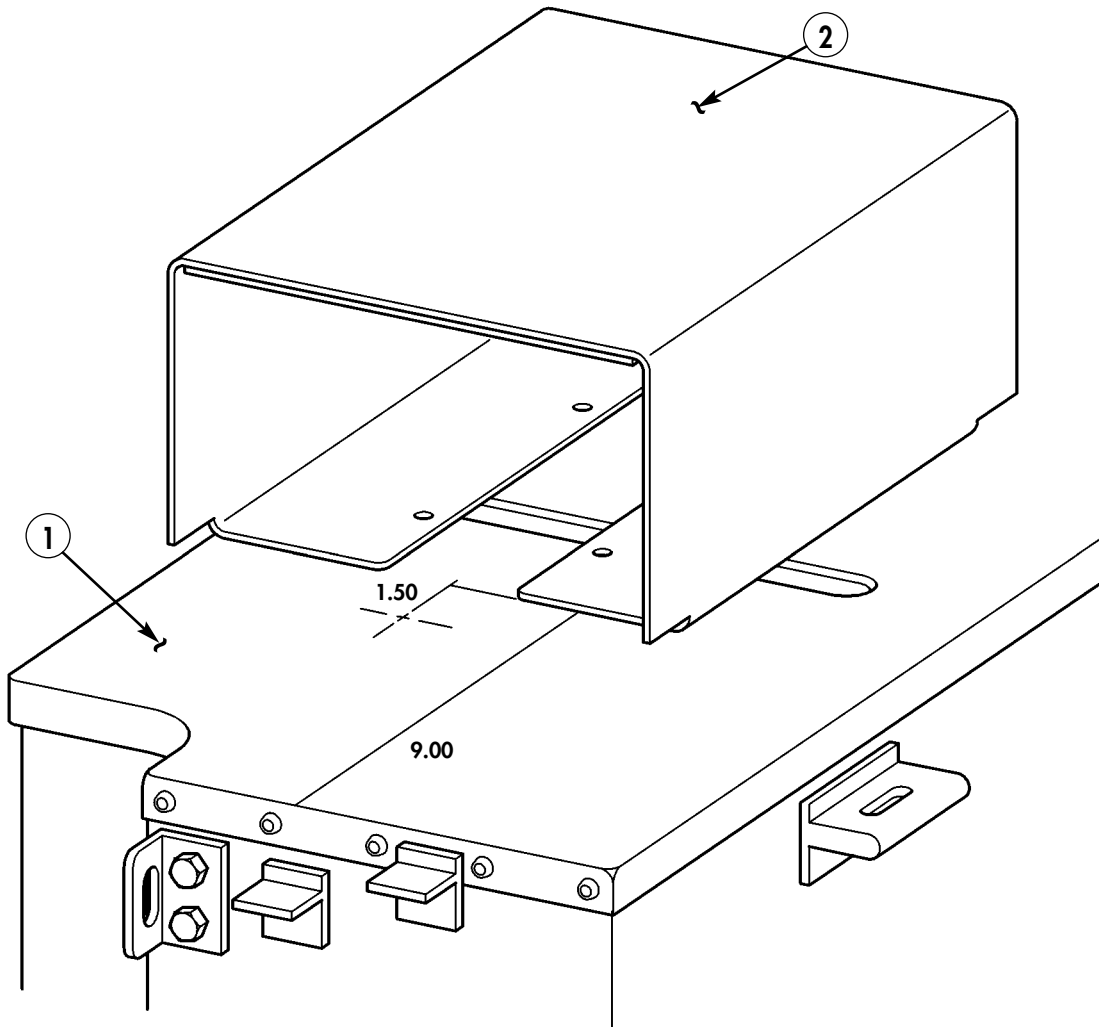

2. COVER - 11080-5425-01 - QTY. 1

Figure 5-33.

NOTE

Remove all rivets that will interfere with mounting radio transmitter enclosure flat against wheelwell.

- 12-3. Remove eight to ten rivets (3) on inside edge of right wheelhouse (1) located under radio transmitter enclosure (2).
- 12-4. Drill one 1.375-in. diameter hole (4) in location taken in step 12-2. Deburr hole (4).

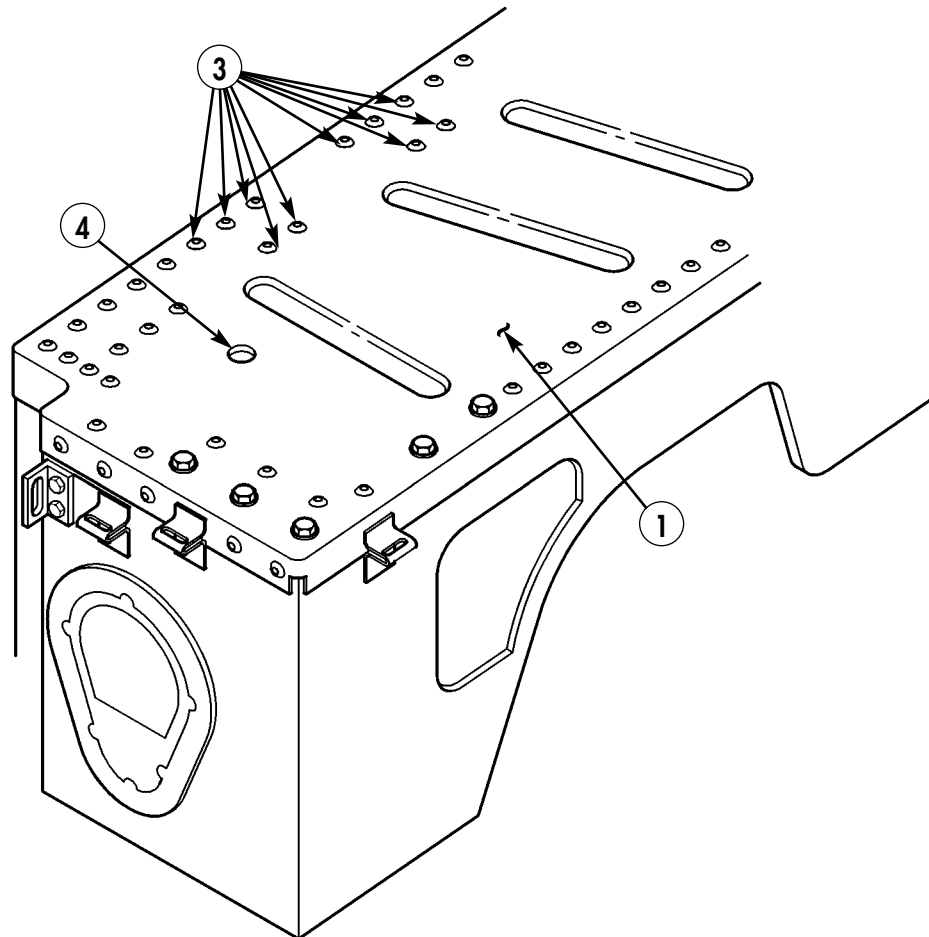

Figure 5-34.

- 12-5. Remove and discard four existing screws (5) and lockwashers (8) from isolation mount top plate (6). Remove isolation mount top plate (6) from isolation mount bottom plate (7).

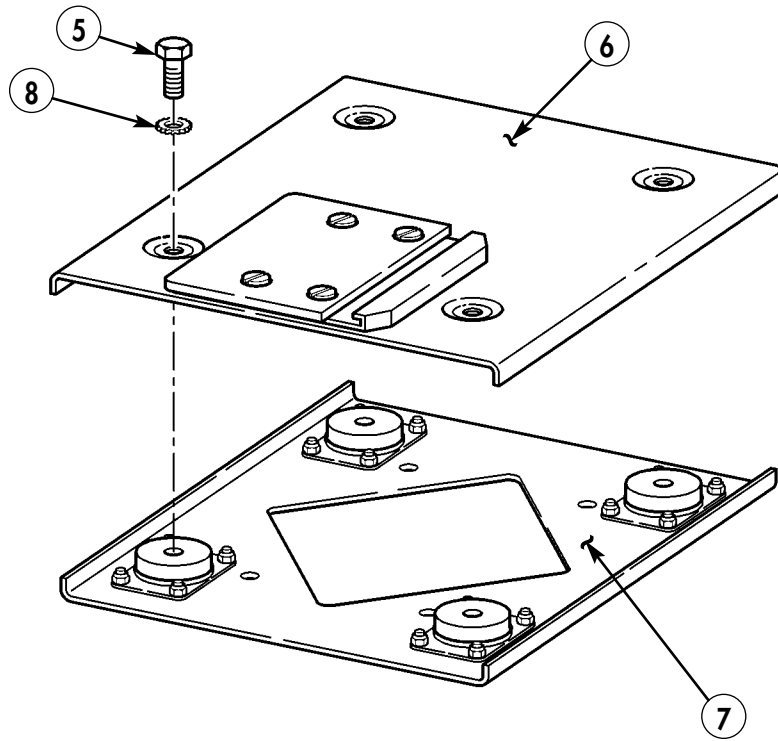
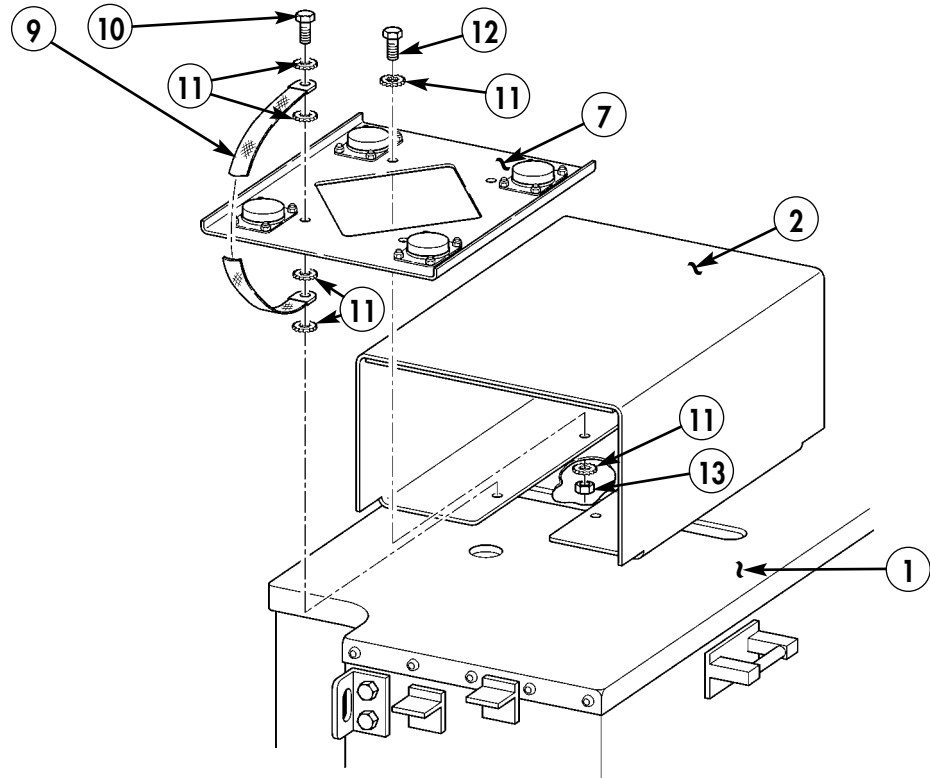

Figure 5-35.

- 12-6. Attach radio transmitter enclosure (2) and isolation mount bottom plate (7) to right rear wheelhouse (1) with three screws (12), six lockwashers (11), and three nuts (13).
- 12-7. Secure radio transmitter enclosure (2) and isolation mount bottom plate (7) to right rear wheelhouse (1) with one screw (10), ground strap (9), five lockwashers (11), and one nut (13).
- 12-8. Install clamp block (15) on mounting base (6) with four included screws (14).



- 9. GROUND STRAP
 - BRAIDED WIRE – AA59569F30T0375 – QTY. A/R
 - TERMINAL LUG – MS20659-141 – QTY. 2
- 10. CAPSCREW – B1821BH025C125N – QTY. 1
- 11. LOCKWASHER – MS45904-68 – QTY. 11
- 12. CAPSCREW – B1821BH025C100N – QTY. 3
- 13. NUT – 9419143 – QTY. 4

Figure 5-36.

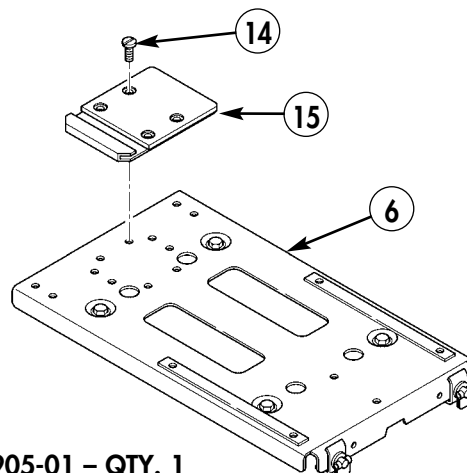

- 14. BLOCK, CLAMP – 12018-1905-01 – QTY. 1

Figure 5-37.

- 12-9. Install locking base (17) to isolation mount top plate (6) with two included screws (16) and Loctite No. 271.
- 12-10. Install lanyard (19) on locking base (17) with included screw (18), lockwasher (20), and Loctite No. 271.
- 12-11. Install lanyard (19) on locking bar (23) with included screw (21) and lockwasher (22).
- 12-12. Attach isolation mount top plate (6) to isolation mount bottom plate (7) with four screws (24) and four lockwashers (25). Position locking bar (23) on locking base (17).

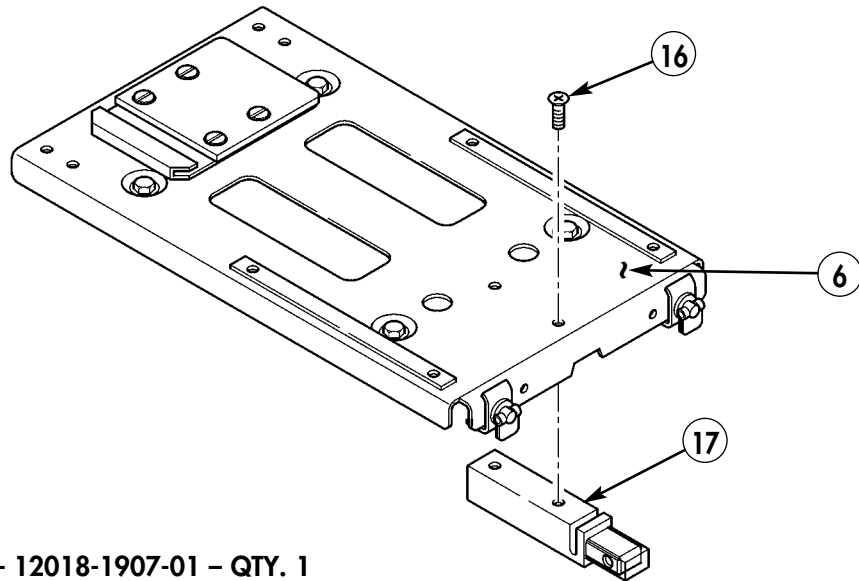

17. LOCKING BASE – 12018-1907-01 – QTY. 1

Figure 5-38.

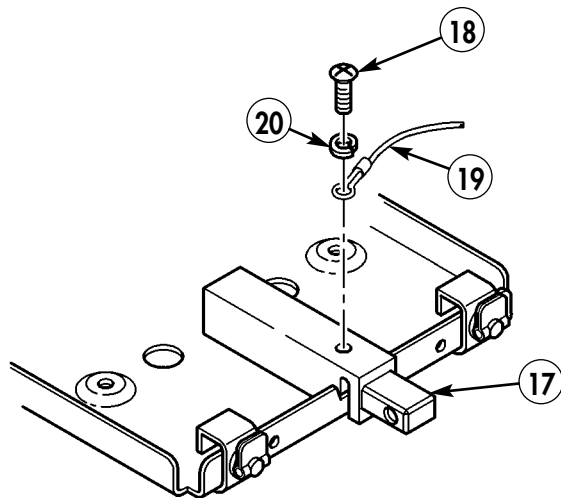

19. LANYARD – Z33-0002-306 – QTY. 1

Figure 5-39.

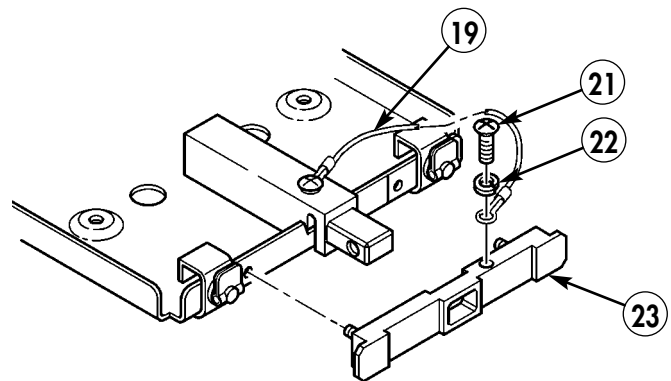

23. LOCKING BAR – 12018-1908-01 – QTY. 1

Figure 5-40.

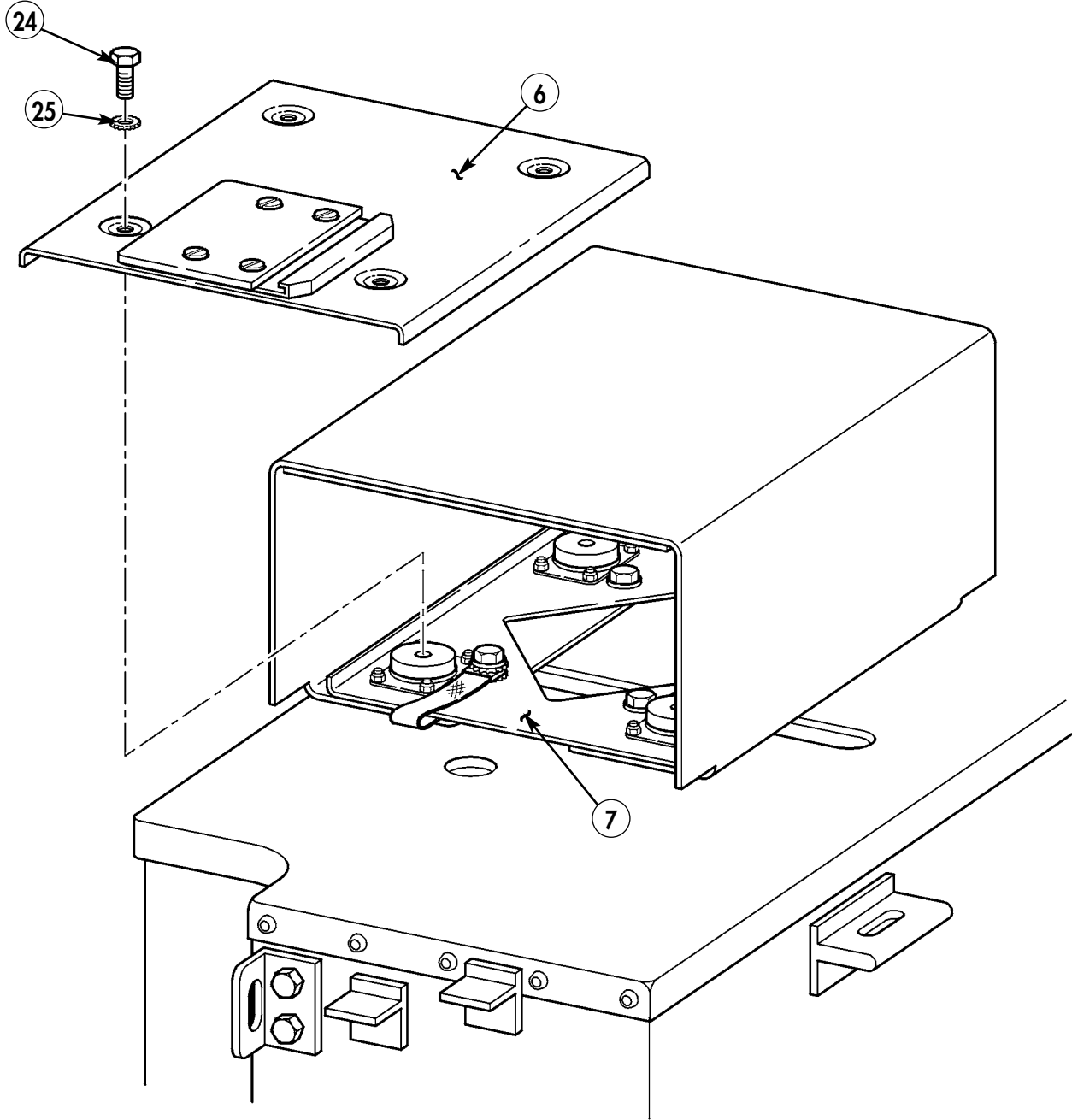

- 24. CAPSCREW - B1821BH025C062N - QTY. 4
- 25. LOCKWASHER - MS45904-68 - QTY. 4

Figure 5-41.

NOTE

Ensure convoluted tubing is cut straight and even to allow proper fit of locking collar.

- 12-13. Install locking collar (26) on one end of convoluted tubing (27)
- 12-14. Place convoluted tubing (27) in hole (28) in right wheelhouse (1), through wheelhouse (1) and through hole (4) in right wheelhouse (1). Mark convoluted tubing at proper length.
- 12-15. Remove convoluted tubing (27) from wheelhouse (1) and cut to proper length.

NOTE

Ensure convoluted tubing is cut straight and even to allow proper fit of locking collar.

- 12-16. Install locking collar (26) on other end of convoluted tubing (27).
- 12-17. Place convoluted tubing (27) in hole (4) in top of right wheelhouse (1), through wheelhouse (1) and through hole in rear wall (28). Secure with nylon nuts (29).

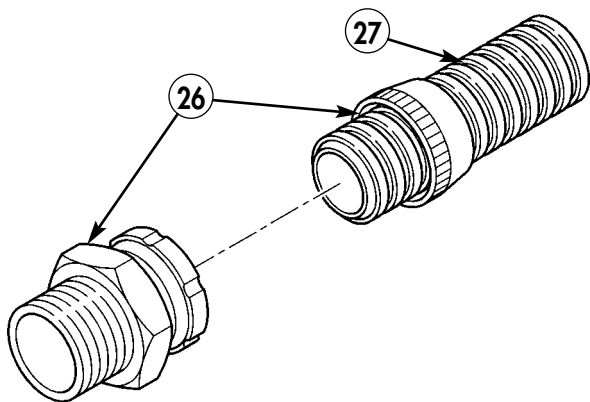

- 26. LOCKING COLLAR - Z52-0013-002 - QTY. 2
- 27. CONVOLUTED TUBING - Z52-0013-001 - QTY. 1

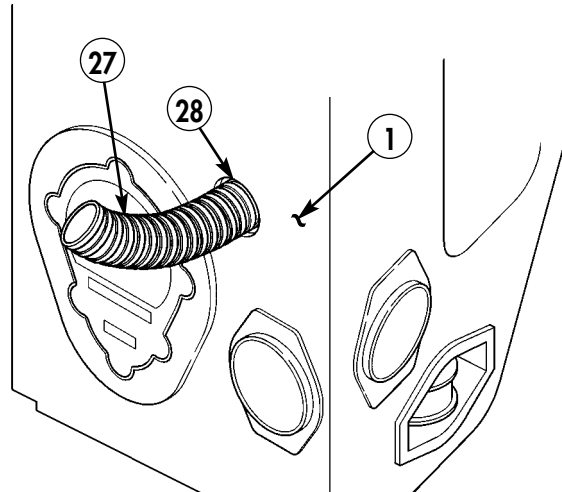
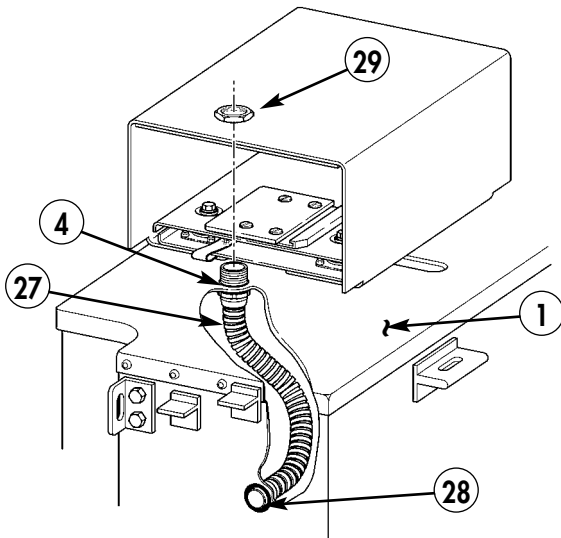

Figure 5-42.



- 29. NYLON NUT - 10075-1397 - QTY. 2

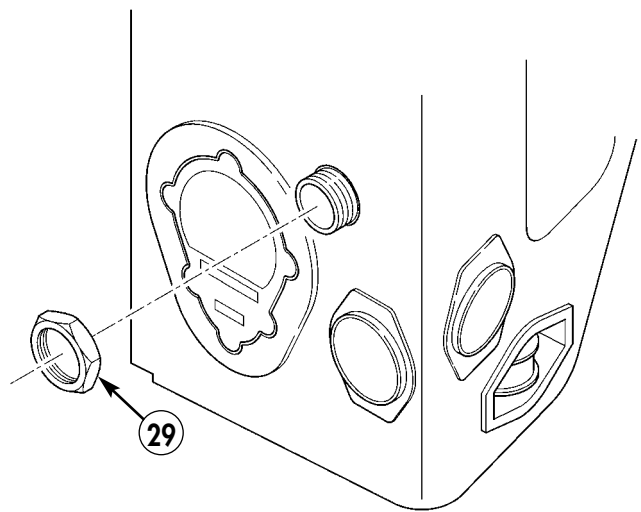
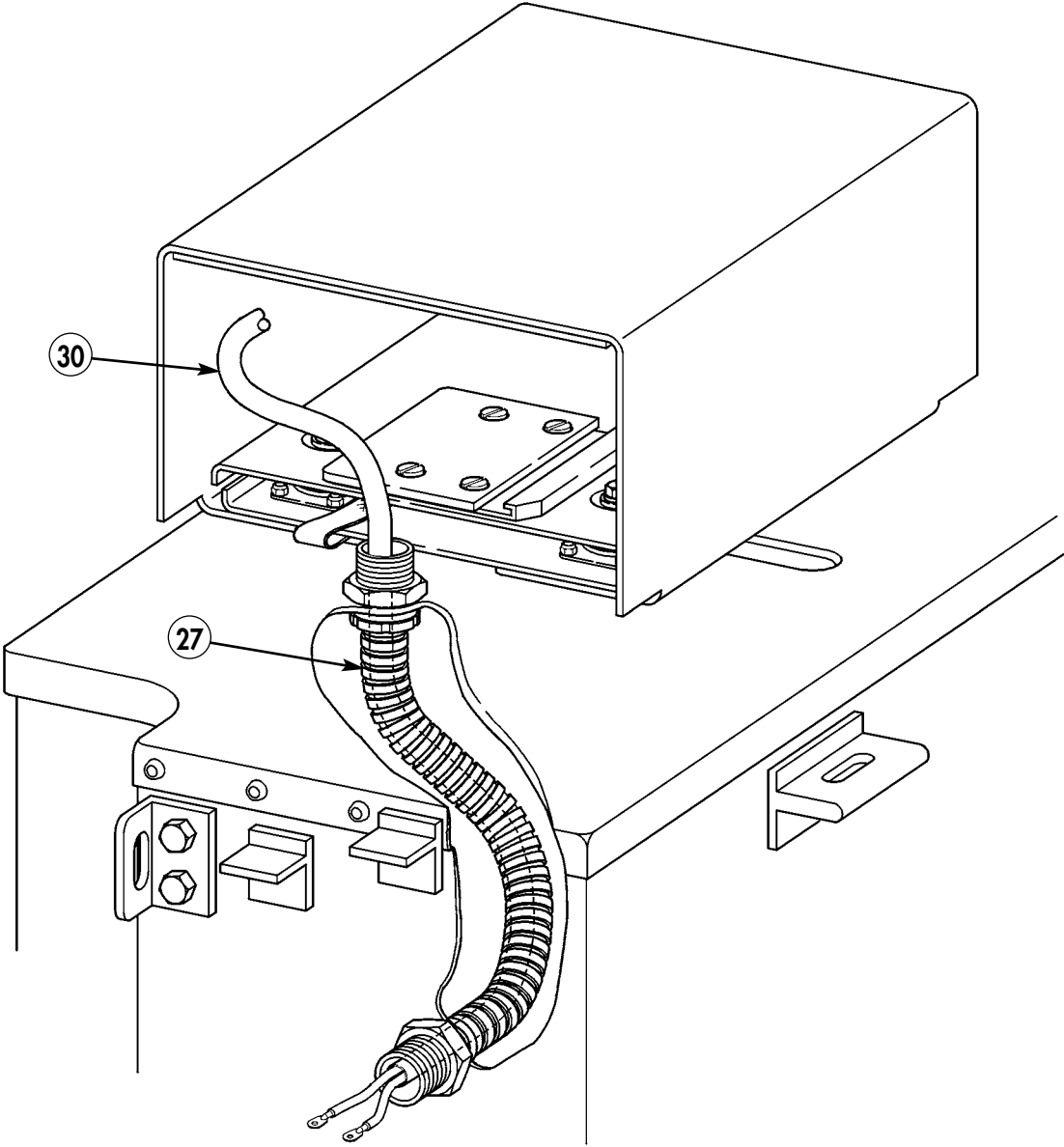

Figure 5-43.

12-18. Route antenna cable (30) through convoluted tubing (27).



30. HF ANTENNA CABLE – 10564-3355-A004 – QTY. 1

Figure 5-44.

Section XIII. ANTENNA BRACKET AND ANTENNA INSTALLATION

NOTE

Do not tighten screws at this time.

- 13-1. Attach antenna mount (5) to rear wall of right rear wheelhouse (3) with three capscrews (6), six lockwashers (2), three aluminum spacers (4), and nuts (1).
- 13-2. Temporarily install support bar (7) on antenna mounting bracket (5).
- 13-3. Using support bar (7) as template, locate and mark two hole locations (8). Remove support bar (7).
- 13-4. Drill two 0.281-in. diameter holes (8) in right rear wheelhouse (3).

NOTE

Do not tighten bolts at this time.

- 13-5. Attach support bar (7) to antenna support bracket with two capscrews (13), lockwashers (10), and washers (11).

NOTE

Do not tighten capscrews at this time.

- 13-6. Attach support bar (7) to right rear wheelhouse (3) with two capscrews (12), washers (11), spacers (4), lockwashers (10), and nuts (9).
- 13-7. Tighten top two capscrews (6) securing antenna mounting bracket (5) to right rear wheelhouse (3).
- 13-8. Tighten two capscrews (13) securing support bar (7) to antenna mounting bracket (5).
- 13-9. Tighten two capscrews (12) securing support bar (7) to right rear wheelhouse (3).

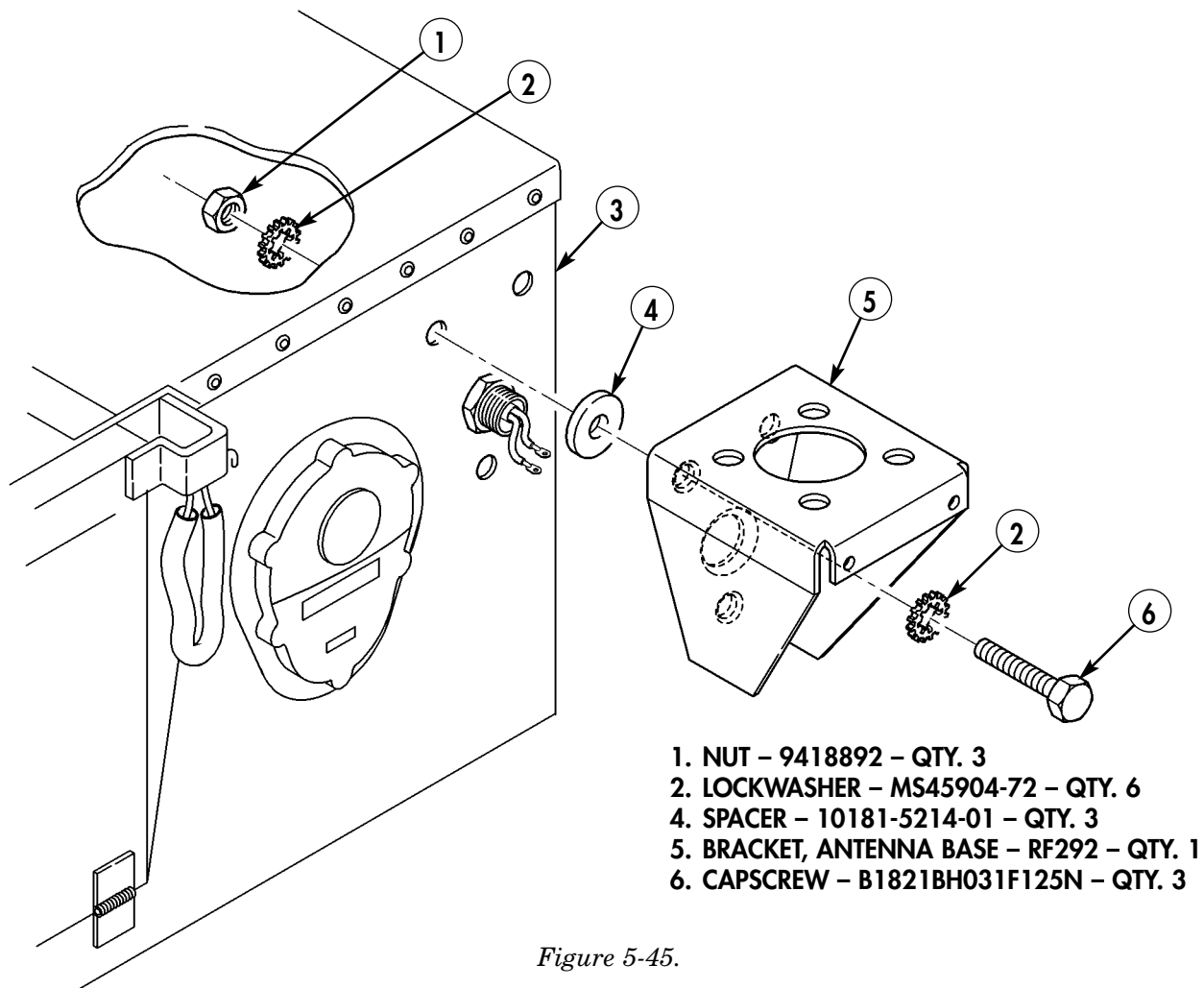

Figure 5-45.

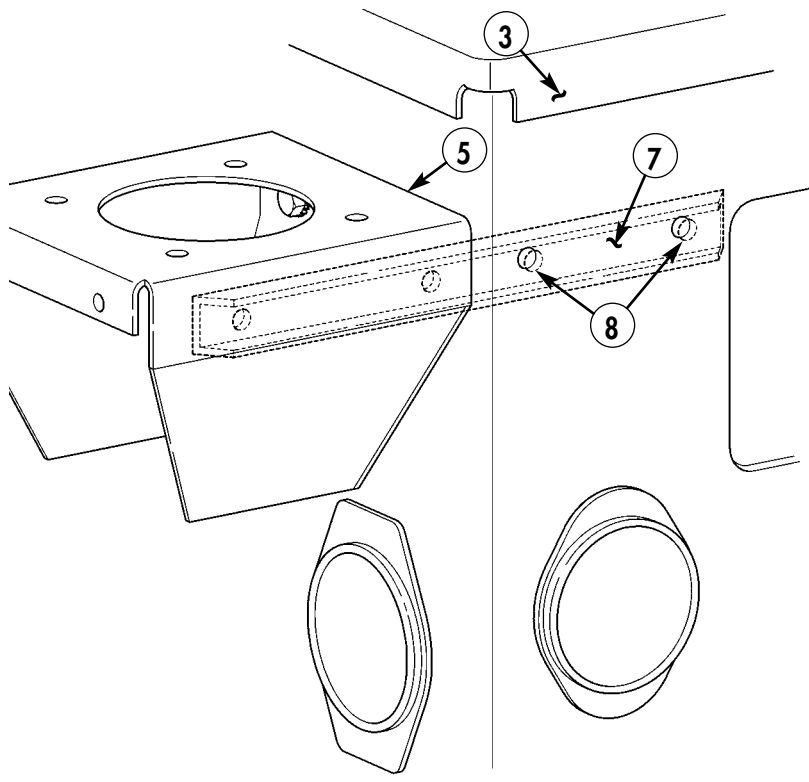
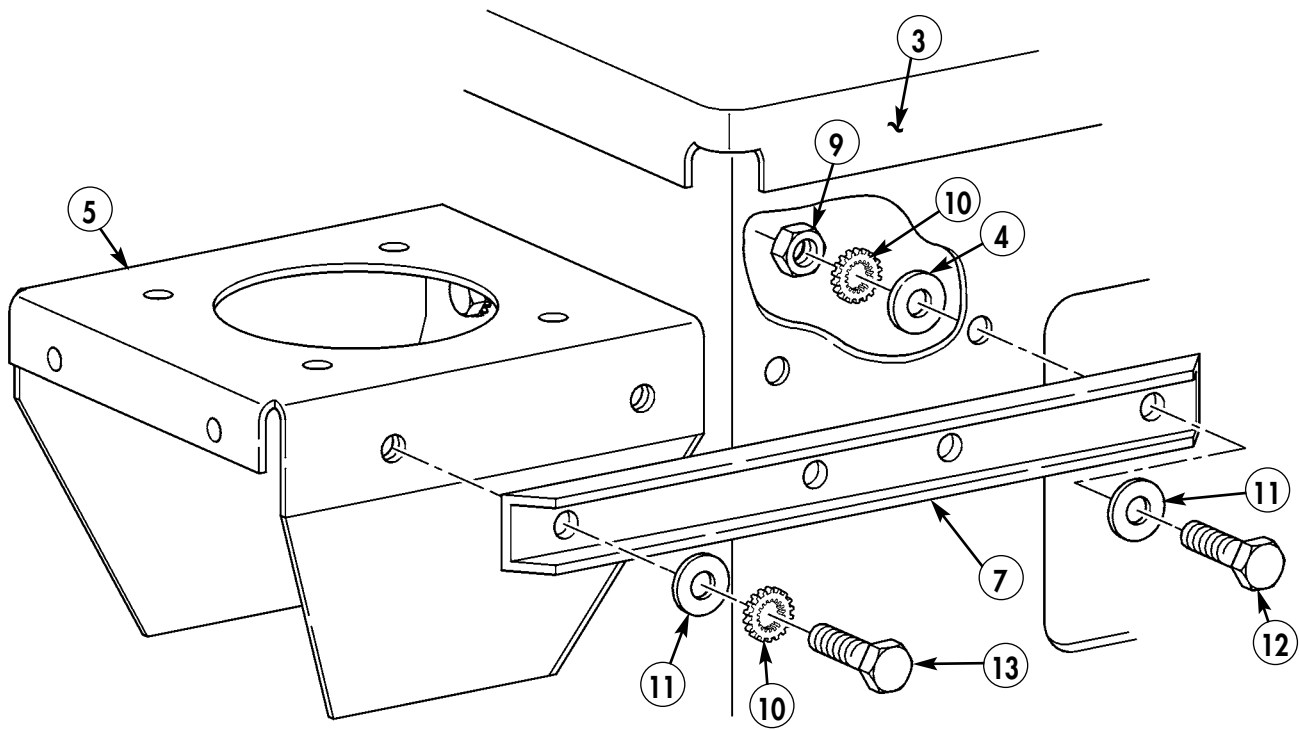

Figure 5-46.



- 4. SPACER - 10181-5214-01 - QTY. 2
- 7. BAR, SUPPORT - 10181-5213-002 - QTY. 1
- 9. NUT - 9419143 - QTY. 2
- 10. LOCKWASHER - MS45904-72 - QTY. 4

- 11. WASHER - MS27183-10 - QTY. 6
- 12. CAPSCREW - B1821BH025C100N - QTY. 2
- 13. CAPSCREW - B1821BH025C088N - QTY. 2

Figure 5-47.

- 13-10. Attach ground strap (17) to antenna base (16) and position antenna base (16) on antenna mounting bracket (5).
- 13-11. Install terminal lug (18) on ground strap (17).
- 13-12. Remove bottom capscrew (6) and lockwashers (2) from antenna mounting bracket (5). Secure antenna ground strap (17) to right rear wheelhouse (3) and antenna mounting bracket (5) with existing capscrew (6), three lockwashers (2), and nut (1).
- 13-13. Secure antenna base (16) to antenna mounting bracket (5) with four capscrews (14) and lockwashers (15).

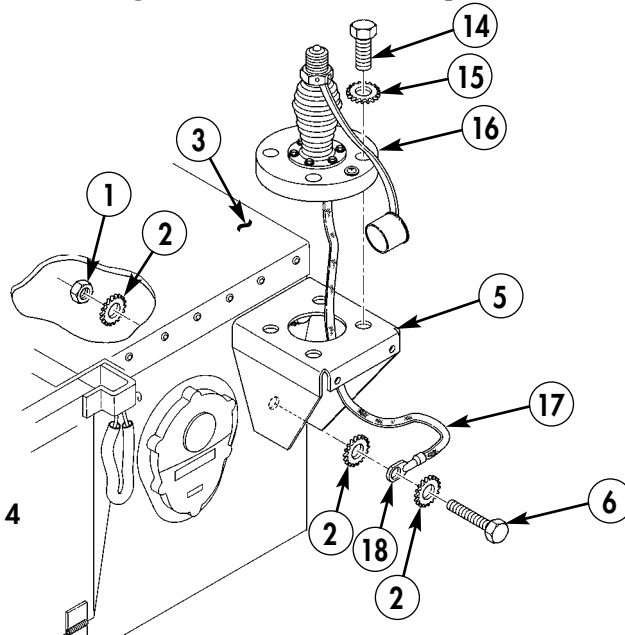

- 2. LOCKWASHER – MS45904-72 – QTY. 1
- 14. CAPSCREW – B1821BH038F175N – QTY. 4
- 15. LOCKWASHER – MS45904-76 – QTY. 4
- 16. ANTENNA – 4245 – QTY. 1
- 18. TERMINAL LUG – MS20659-108 – QTY. 1

Figure 5-48.

NOTE

Ensure antenna adapter tilts fore and aft of vehicle after tightening.

- 13-14. Install antenna adapter (19) on antenna base by screwing on until tight.
- 13-15. Secure with existing clamp (20).

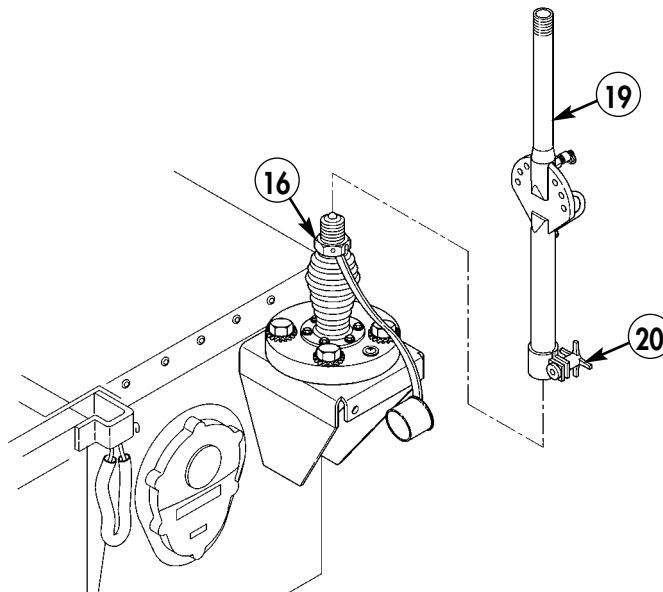

- 19. ANTENNA ADAPTER – RF-1980-AT001 – QTY. 1

Figure 5-49.

13-16. Install cover plate (22) on antenna mounting bracket (5) with three screws (13), washers (11), and lockwashers (21).

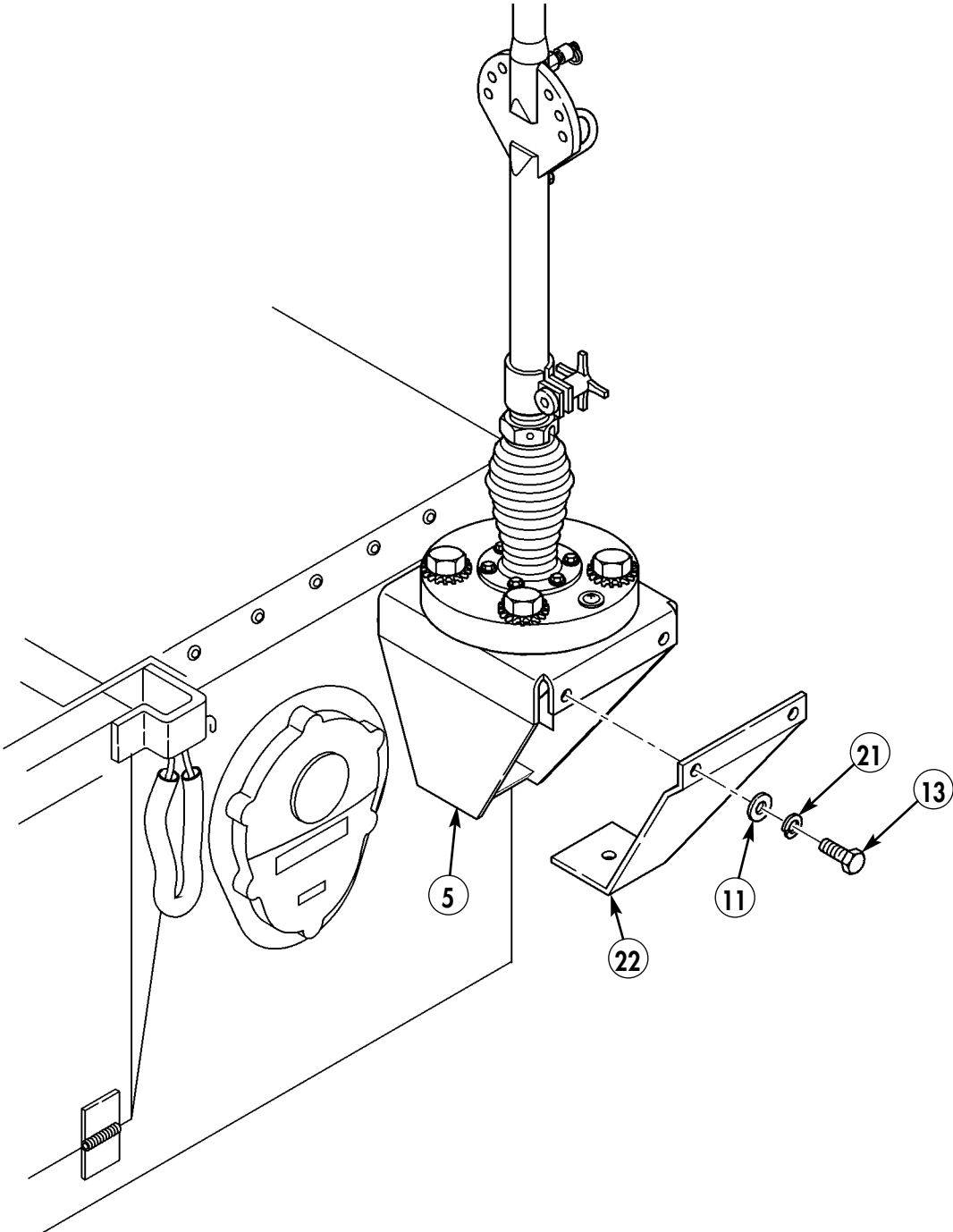

- 11. WASHER – MS27183-10 – QTY. 3
- 13. CAPSCREW – B1821BH025C088N – QTY. 3
- 21. LOCKWASHER – MS35338-44 – QTY. 3
- 22. COVER, ANTENNA BRACKET – 1018-5212-02 – QTY. 1

Figure 5-50.

Section XIV. REAR SINGARS ANTENNA INSTALLATION

NOTE

This procedure applies to vehicles without existing antennas. For vehicles with existing antennas, remove all control cables. (Refer to TM 9-2320-280-20.)

- 14-1. Using antenna mounting bracket (3) as template, locate, mark, and drill one 1.375-in. diameter hole (4) in left rear wall (2).
- 14-2. Locate, mark, and drill three 0.343-in. diameter holes (1) in rear wall (2).
- 14-3. Remove paint from vicinity of three holes (1) and three matching holes in antenna mounting bracket (3).
- 14-4. Apply anti-seize compound to vicinity of three holes (1) and rear of antenna mounting bracket (3).

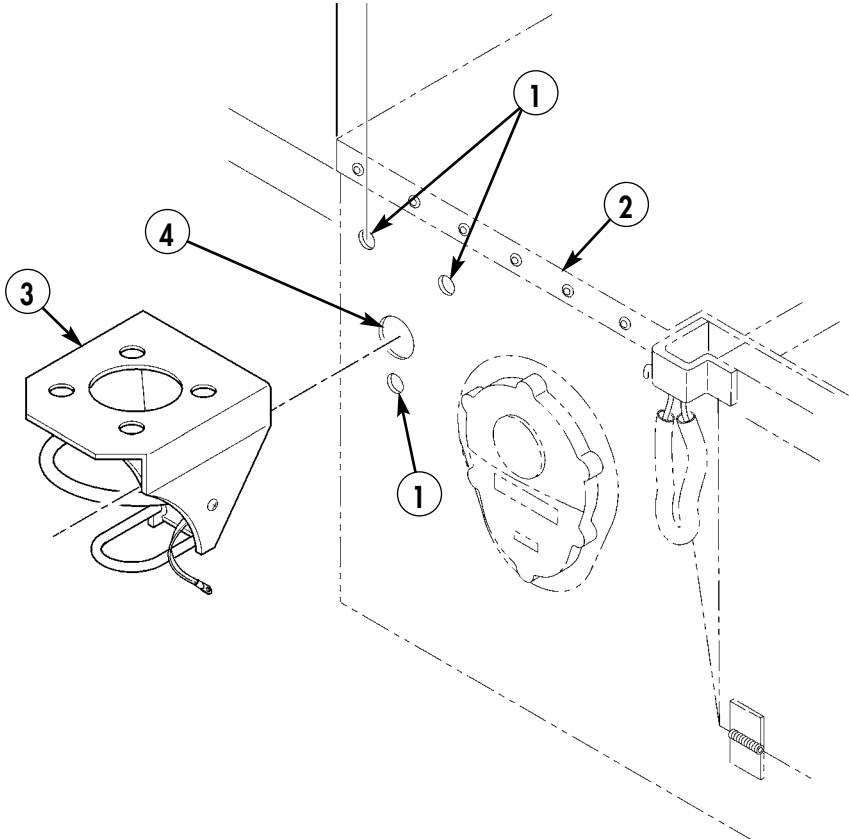

3. ANTENNA MOUNTING BRACKET – A3014546-1 – QTY. 1

Figure 5-51.

- 14-5. Install grommet (8) in hole (4) of rear wall (2).
- 14-6. Position antenna (7) and gasket (15) on antenna mounting bracket (3) and route existing ground strap (13) through antenna mounting bracket (3).
- 14-7. Install antenna (7) on antenna mounting bracket (3) with four capscrews (5), eight lockwashers (6), and four nuts (14).
- 14-8. Install antenna mounting bracket (3) on rear wall (2) with two capscrews (12), lockwashers (6), washers (9), and nuts (10).
- 14-9. Remove old terminal lug and install new terminal lug (11) on ground strap (13). Install ground strap (13) and antenna mounting bracket (3) on rear wall (2) with capscrew (12), lockwasher (6), washer (9), and nut (10).

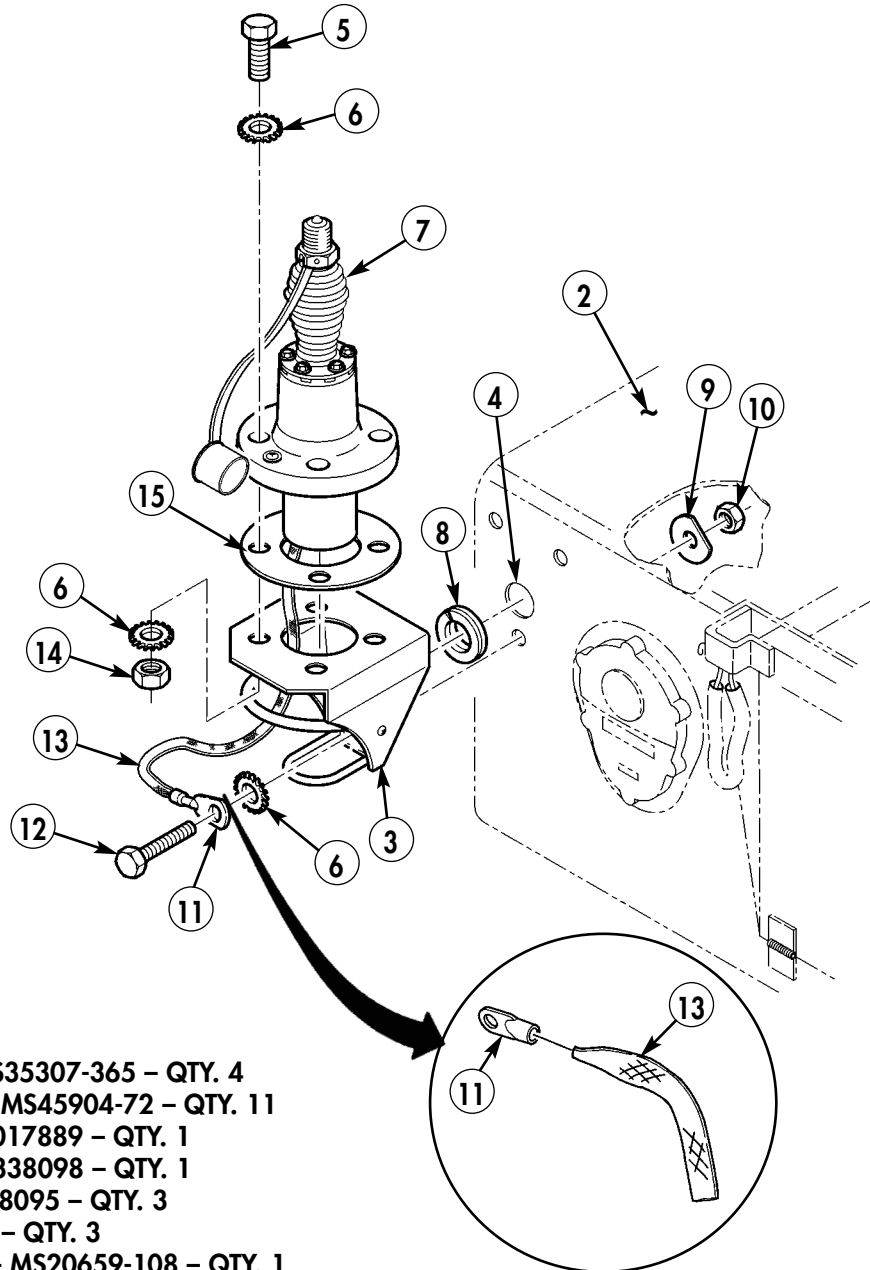

- 5. CAPSCREW - MS35307-365 - QTY. 4
- 6. LOCKWASHER - MS45904-72 - QTY. 11
- 7. ANTENNA - A3017889 - QTY. 1
- 8. GROMMET - 12338098 - QTY. 1
- 9. WASHER - 12338095 - QTY. 3
- 10. NUT - 9418892 - QTY. 3
- 11. TERMINAL LUG - MS20659-108 - QTY. 1
- 12. CAPSCREW - B1821BH031F125N - QTY. 3
- 14. NUT - 13218E0320-293 - QTY. 4
- 15. GASKET - A3013655-1 - QTY. 1

Figure 5-52.

- 14-10. Attach upper antenna element (16) to lower antenna element (18).
- 14-11. Attach antenna assembly to antenna base (7).
- 14-12. Attach fiber rope assembly (17) to upper antenna element (16).
- 14-13. Secure lower antenna element (18) to antenna base (7) with lockwire (19).

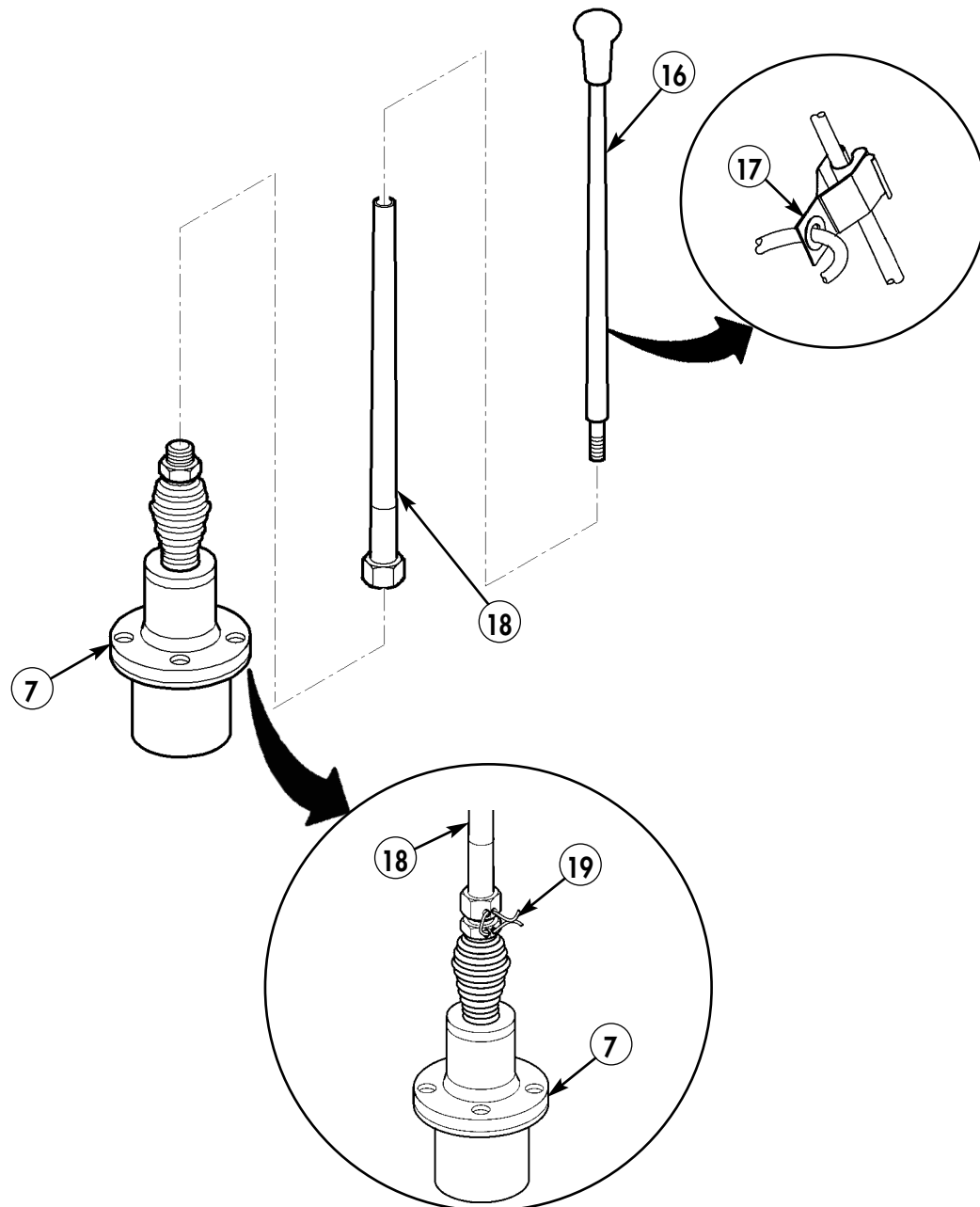

- 16. UPPER ANTENNA ELEMENT - A3017901-2 - QTY. 1
- 17. FIBER ROPE ASSEMBLY - A3167672-1 - QTY. 1
- 18. LOWER ANTENNA ELEMENT - A3018230-1 - QTY. 1
- 19. LOCKWIRE - MS20995C32 - QTY. A/R

Figure 5-53.

Section XV. CABLES INSTALLATION

NOTE

- This procedure applies to vehicles without existing antennas. For vehicles with existing antennas, remove all control cables. (Refer to TM 9-2320-280-20.)
- Loosen left- and right-side tunnel insulation before performing steps 15-1, 15-3, 15-4, and 15-8. (Refer to TM 9-2320-280-20.)
- SINCGARS model AN/VRC-92F shown.

15-1. Route loudspeaker cable (1) down through center access hole (2), under integrated rack (3), and under right-side tunnel insulation (4) towards right speaker (5). Connect loudspeaker cable (1) to right speaker (5). Coil excess loudspeaker cable (1) and store under integrated rack (3).

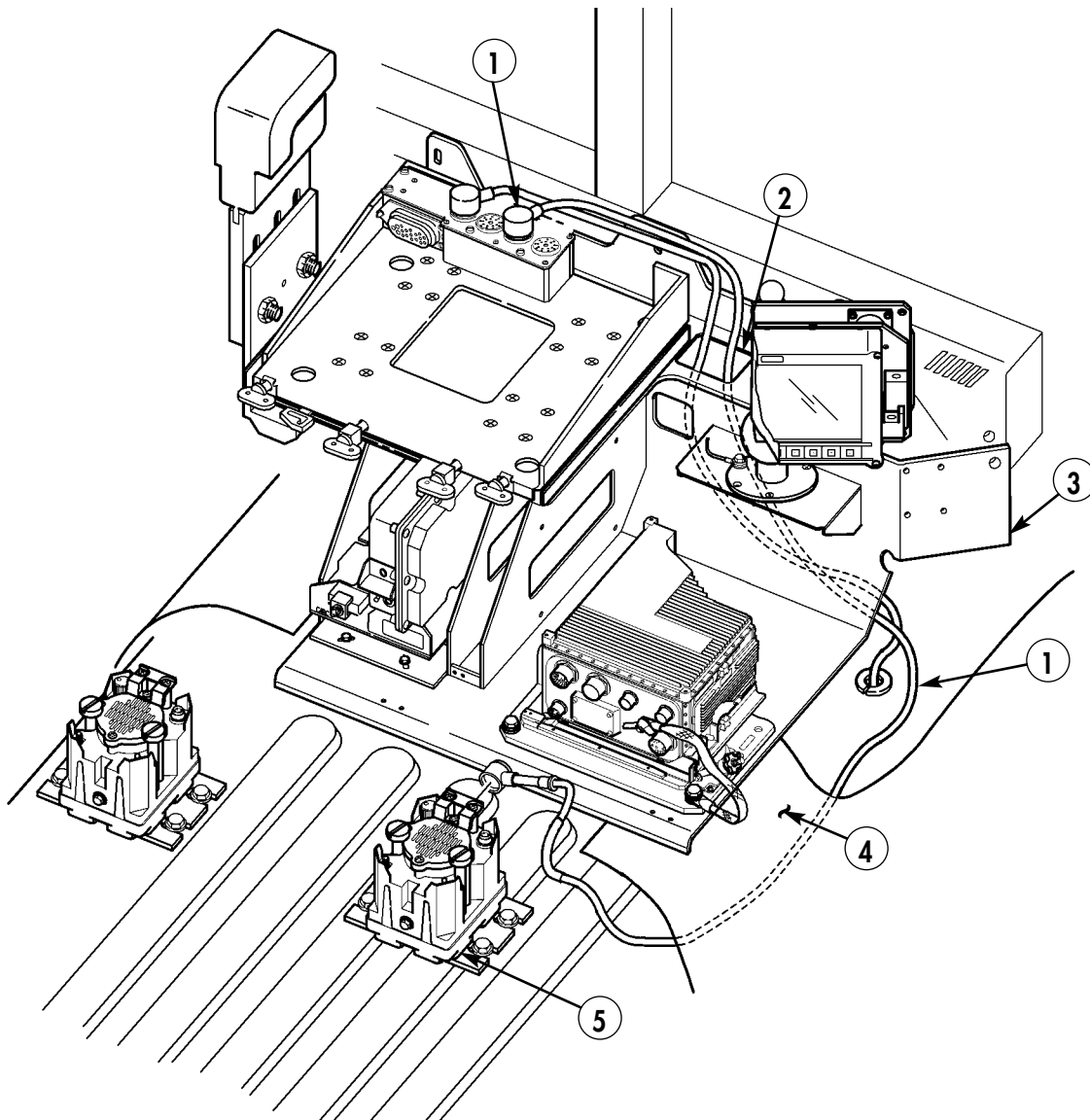

1. LOUDSPEAKER CABLE — A3014038-3 — QTY. 1

Figure 5-54.

NOTE

SINGGARS model AN/VRC-92F shown.

- 15-2.** Route loudspeaker cable (1) down through center access hole (2), under integrated rack (3), and under left-side tunnel insulation (9) towards left speaker (8). Connect loudspeaker cable (1) to left speaker (8).
- 15-3.** Secure loudspeaker cable (1) to integrated rack (3) with loop clamp (12) and existing screw (14), washer (13), lockwasher (11), and nut (10). Do not tighten nut at this time. Coil excess loudspeaker cable (1) and store under integrated rack (3).
- 15-4.** Route antenna cable (6) from left side of mounting base (7), down through center access hole (2), under integrated rack (3), and under right-side tunnel insulation (4) to B-beam.

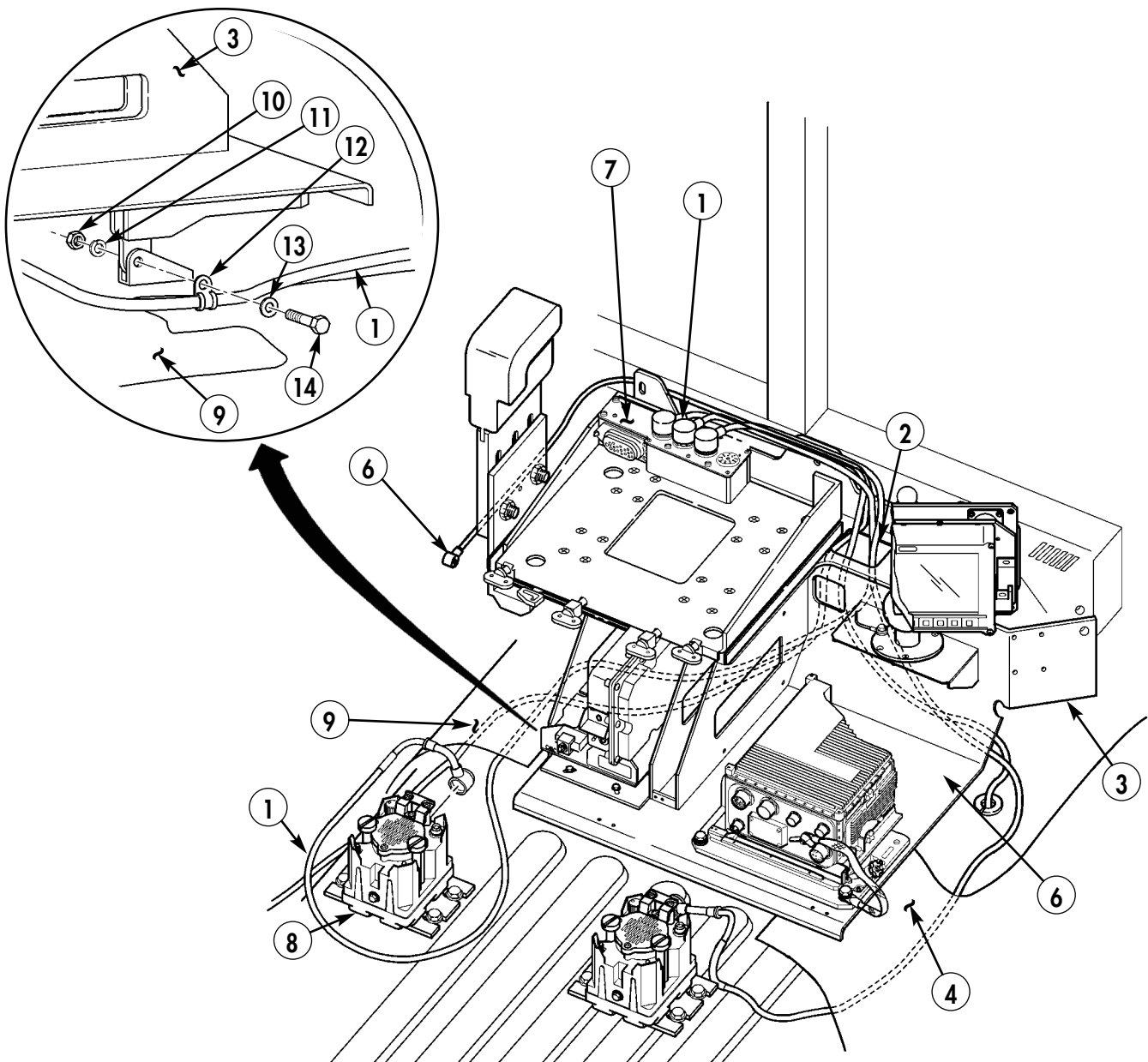

1. LOUDSPEAKER CABLE - A3014038-3 - QTY. 1
 6. ANTENNA CABLE - A3014031-8 - QTY. 1
 12. LOOP CLAMP - MS21333-121 - QTY. 1

Figure 5-55.

NOTE

- Perform steps 15-5 through 15-8 for vehicles with SINCGARS model AN/VRC-92F only.
- Previously routed cables have been removed from figure 5-55 for clarity.

- 15-5.** Route antenna cable (18) from mounting base (7) to MT-6353/VRC mounting base (19).
- 15-6.** Route power amp cable (15) from MT-6353/VRC mounting base (19) up through center access hole (2) and connect to mounting base (7).
- 15-7.** Route control cable (16) from MT-6353/VRC mounting base (19) up through center access hole (2) to mounting base (7).
- 15-8.** Route antenna cable (17) from front of MT-6353/VRC mounting base (19), under integrated rack (3), and under right-side tunnel insulation (4) towards rear of vehicle.

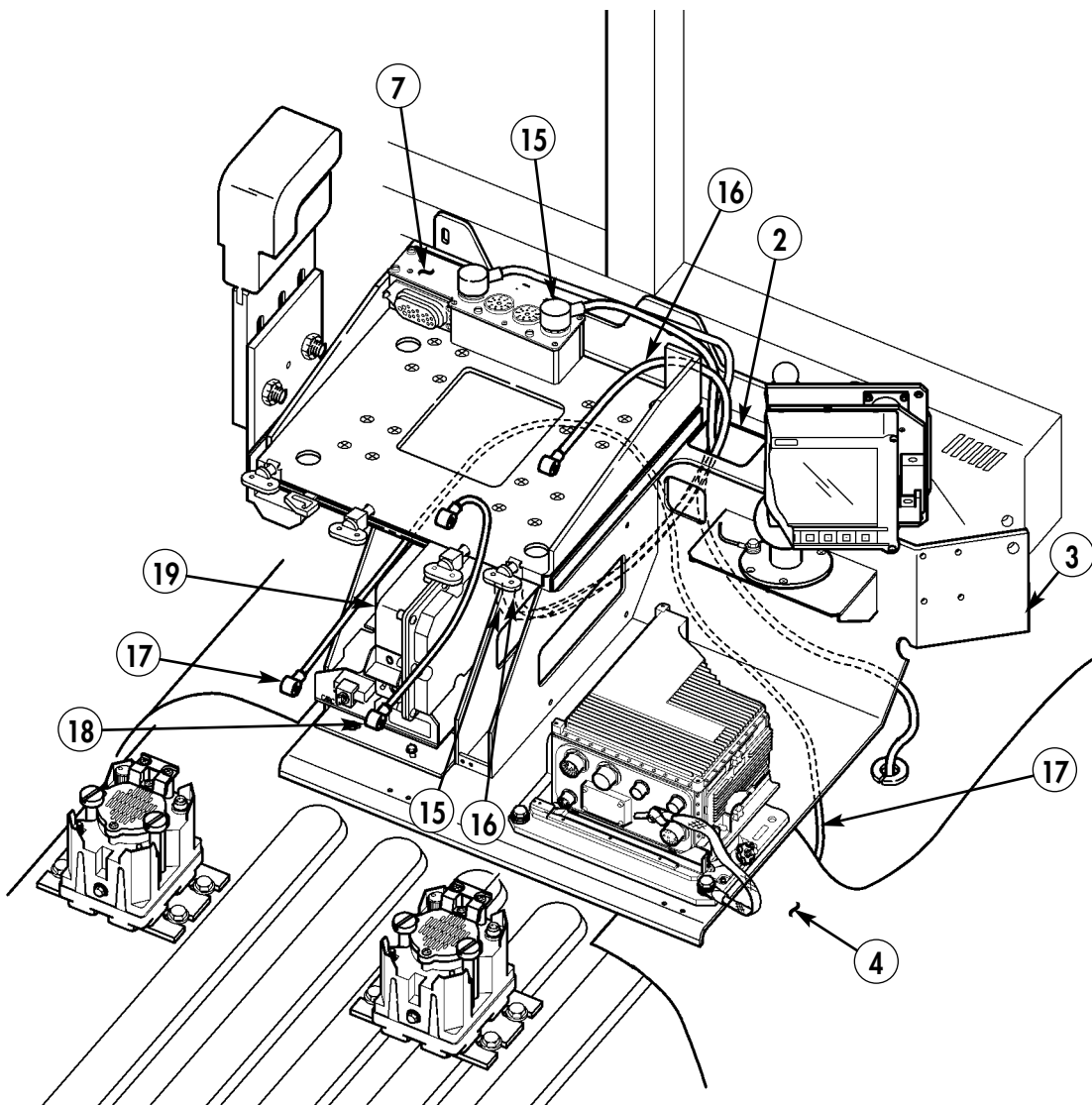

- 17. ANTENNA CABLE – A3014031-17 – QTY. 1**
18. ANTENNA CABLE – A3014032-3 – QTY. 1

Figure 5-56.

NOTE

It may be necessary to drill four 0.147-in. holes in right wheelhouse/utility area before performing step 15-9.

- 15-9. Route antenna cable (17) up B-beam. Secure with tape until antenna and cable are installed in Section XXII.
- 15-10. Route antenna cable (6) along right rear seat/utility area with four self-tapping screws (20) and loop clamps (21).
- 15-11. Route antenna cable (6) through right wheelhouse/utility area with existing grommet, retainer, screws, and plain-assembled nuts. (Refer to TM 9-2320-280-20.)

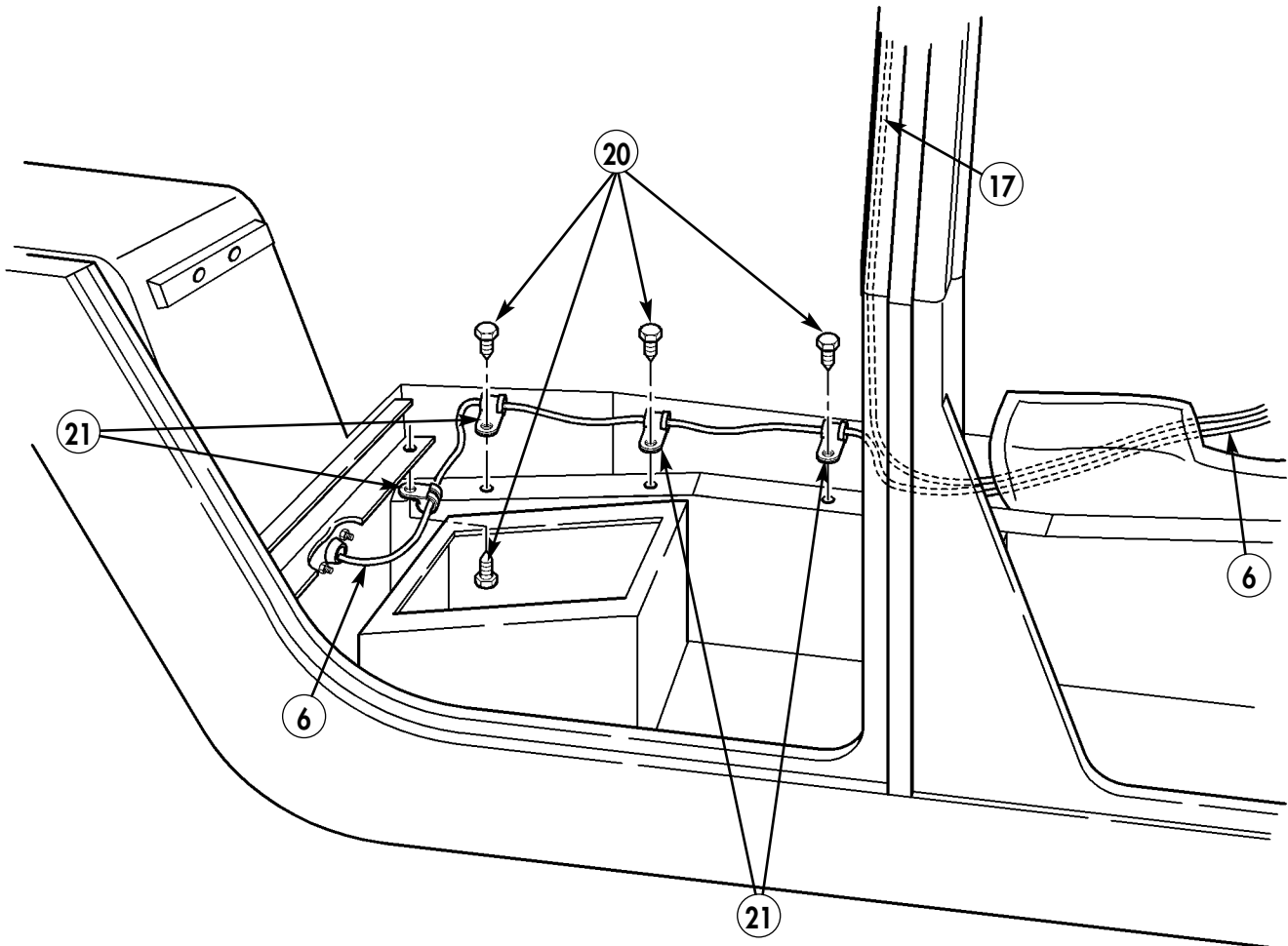

- 20. SELF-TAPPING SCREW – 9421073 – QTY. 4
- 21. LOOP CLAMP – MS21333-75 – QTY. 4

Figure 5-57.

- 15-12.** Route antenna cable (6) along front wheelhouse seam (23) and along front (29), intermediate (28), and rear (27) cargo bed supports. Secure antenna cable (6) to cargo bed supports (29), (28), and (27) with three self-tapping screws (25), loop clamps (26), screw (24), loop clamp (26), and nut (22).

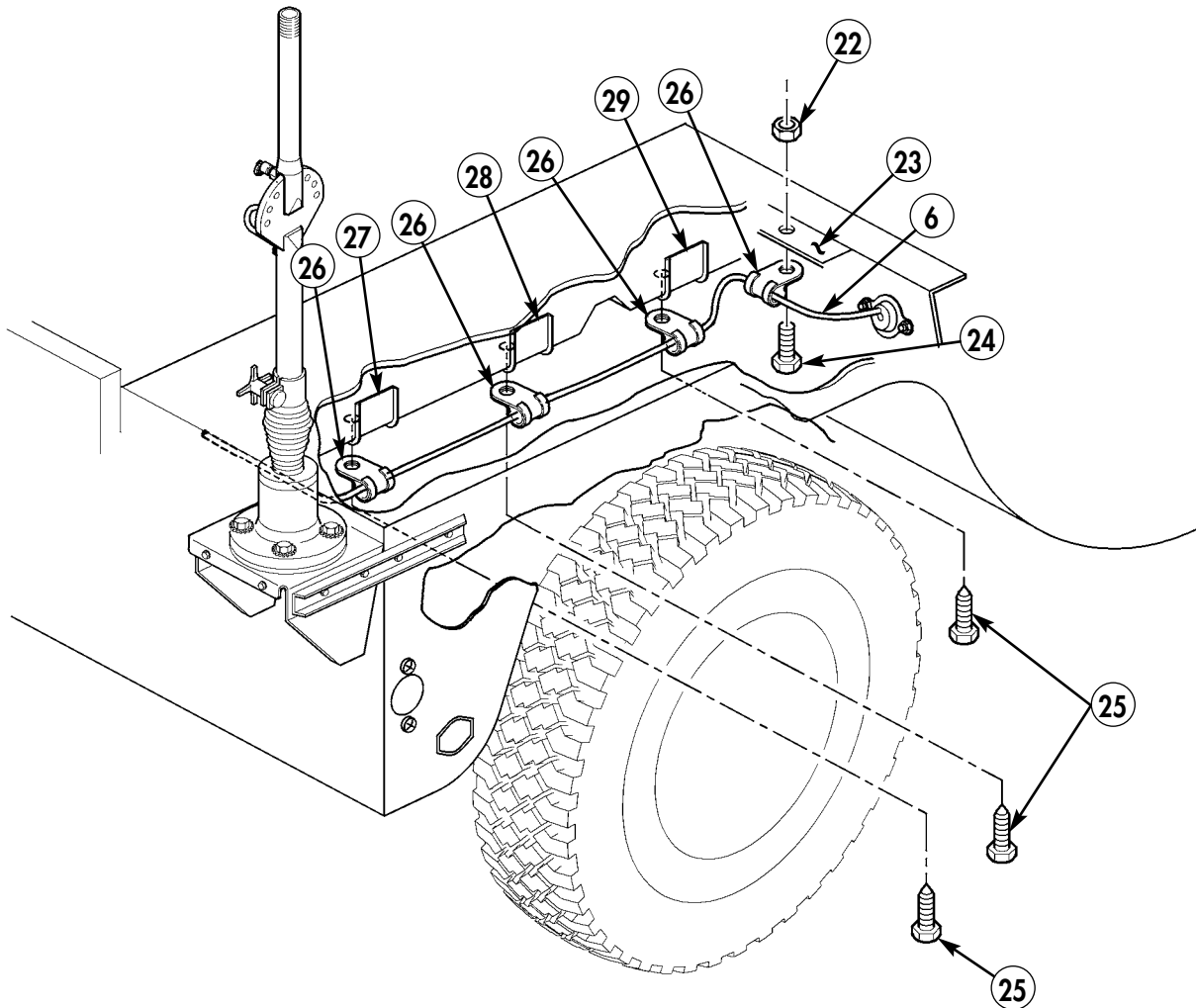

- 22. NUT – MS35650-302 – QTY. 1
- 24. SCREW – MS35224-65 – QTY. 1
- 25. SELF-TAPPING SCREW – 9421073 – QTY. 3
- 26. LOOP CLAMP – MS21333-98 – QTY. 4

Figure 5-58.

- 15-13. Route antenna cable (6) along existing taillight wiring harness (36) on rear cargo bed support (27) and secure with four existing loop clamps (37), (38), (39), (40), and existing self-tapping screws (42).
- 15-14. Route antenna cable (6) along existing taillight wiring harness (36) on left-side frame rail with three existing loop clamps (43), (44), (37), and existing self-tapping screws (42) and (34), lockwasher (35), and loop clamp (37), screw (48), lockwasher (47), washer (45), and nut (46).
- 15-15. Route antenna cable (6) to antenna base (30) and secure with loop clamp (31), screw (49), lockwasher (32), and nut (33).
- 15-16. Attach antenna cable (6) to antenna base (30).
- 15-17. Coil excess antenna cable (6) and secure with tiedown strap (41).

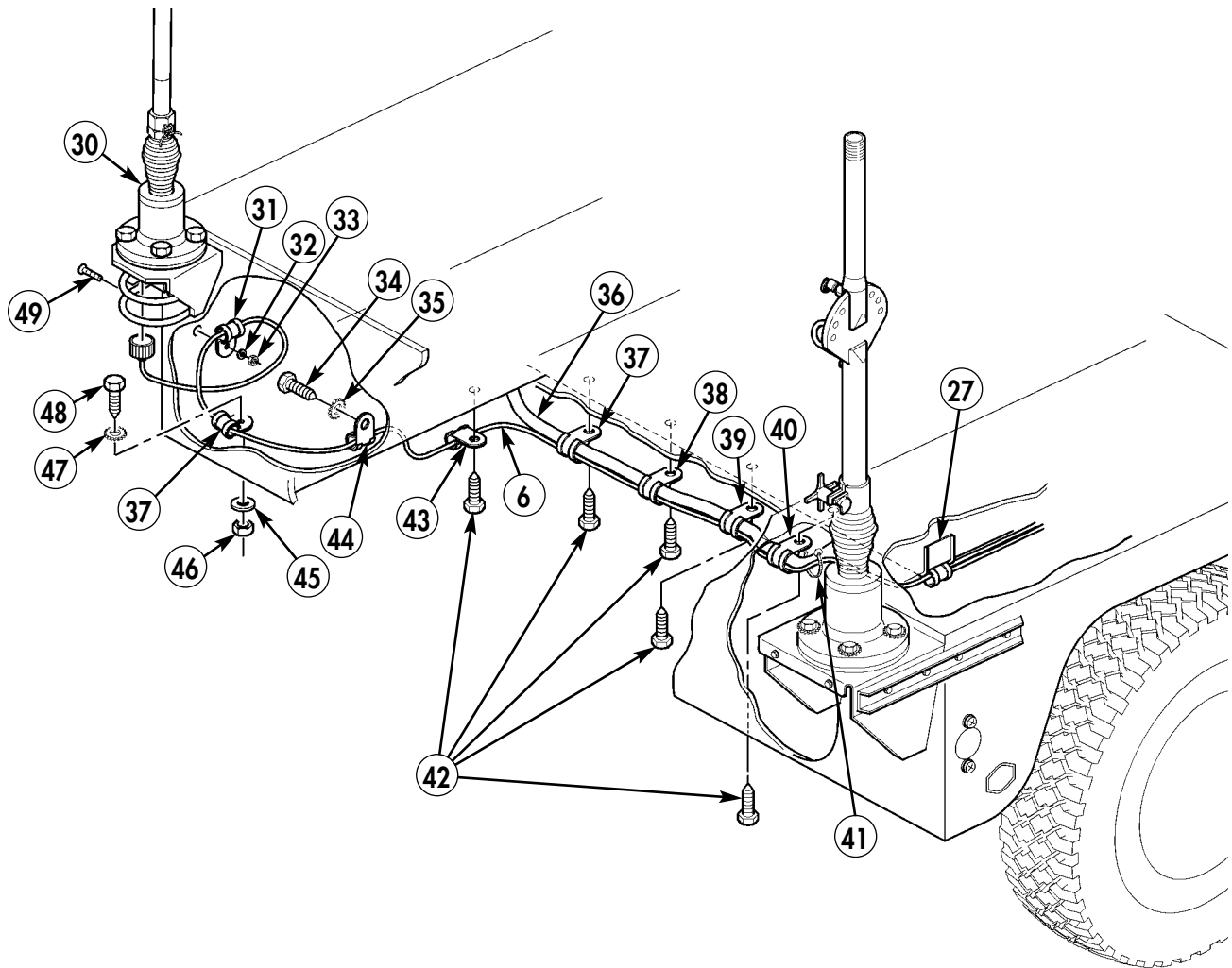

- 31. LOOP CLAMP – MS21333-98 – QTY. 1
- 41. TIEDOWN STRAP – MS3367-1-0 – QTY. A/R

Figure 5-59.

Section XVI. PLGR BRACKET INSTALLATION

- 16-1. Install PLGR bracket (10) on integrated rack (12) with four screws (11).
- 16-2. Locate, mark, and drill one 0.201-in. diameter hole (8) in right-side engine tunnel (9).
- 16-3. Remove paint from vicinity of hole (1) on integrated rack (12) and hole (8) on right-side engine tunnel (9). Apply anti-seize compound as required.
- 16-4. Fabricate ground strap (5) from 8.00-in. length of braided wire and two terminal lugs.
- 16-5. Install ground strap (5) on integrated rack (12) with capscrew (6), two lockwashers (4), lockwasher (2), and nut (3).
- 16-6. Install ground strap (5) on right-side engine tunnel (9) with self-tapping screw (7) and two lockwashers (4).

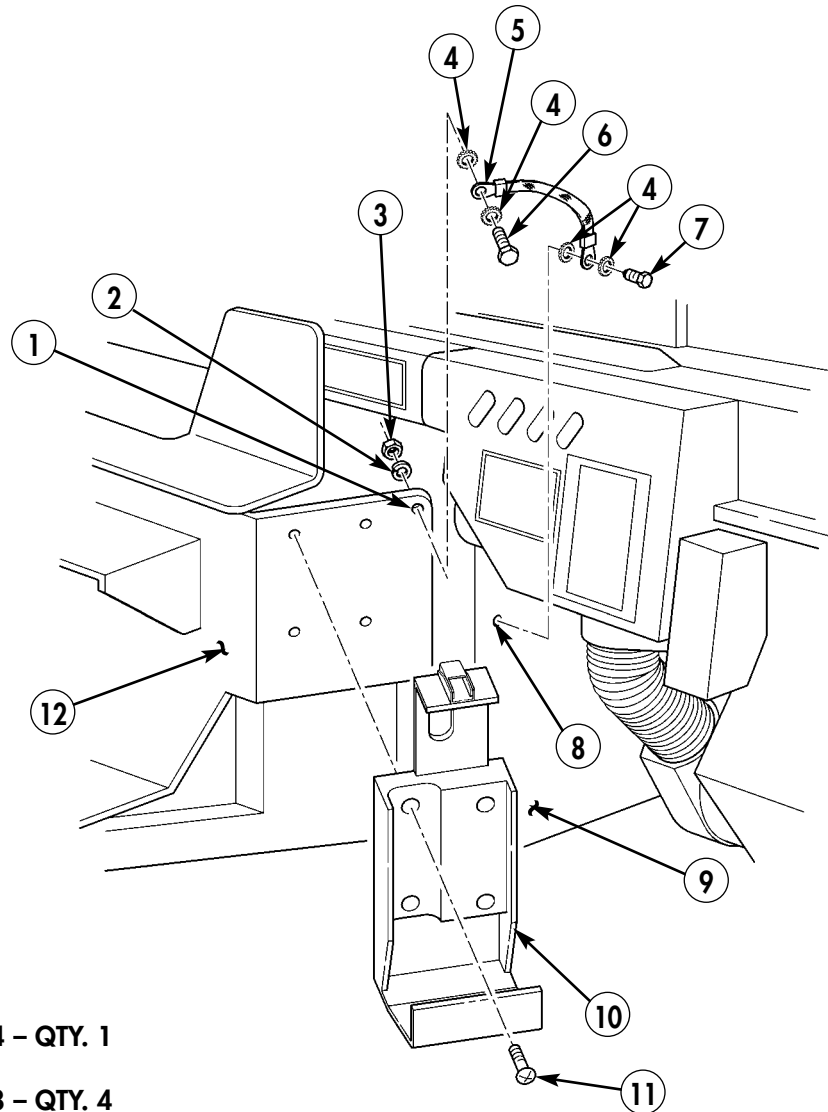

- 2. LOCKWASHER – MS35338-44 – QTY. 1
- 3. NUT – 9419143 – QTY. 1
- 4. LOCKWASHER – MS45904-68 – QTY. 4
- 5. GROUND STRAP
 - BRAIDED WIRE – AA59569F30T0375 – QTY. A/R
 - TERMINAL LUG – MS20659-129 – QTY. 2
- 6. CAPSCREW – B1821BH025C100N – QTY. 1
- 7. SELF-TAPPING SCREW – 9426241 – QTY. 1
- 10. PLGR BRACKET – 986-0645-001 – QTY. 1
- 11. SCREW – MS35206-263 – QTY. 4

Figure 5-60.

Section XVII. PLGR ANTENNA AND CABLE INSTALLATION

- 17-1. Remove two plugs (1) from outer right-side windshield frame (3).

NOTE

Drilled holes on inside and outside of windshield frame should align to allow routing of PLGR cable through windshield frame.

- 17-2. Locate, mark, and drill one 0.375-in. diameter hole (2) in outer right-side windshield frame (3).

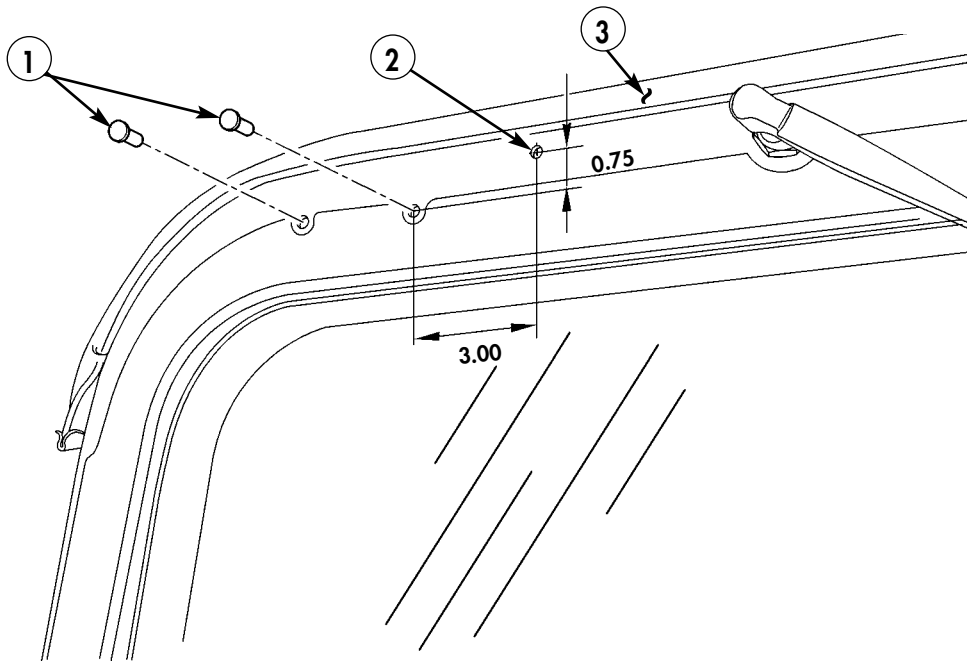

Figure 5-61.

- 17-3. Locate, mark, and drill one 0.375-in. diameter hole (4) in inner right-side windshield frame (5).

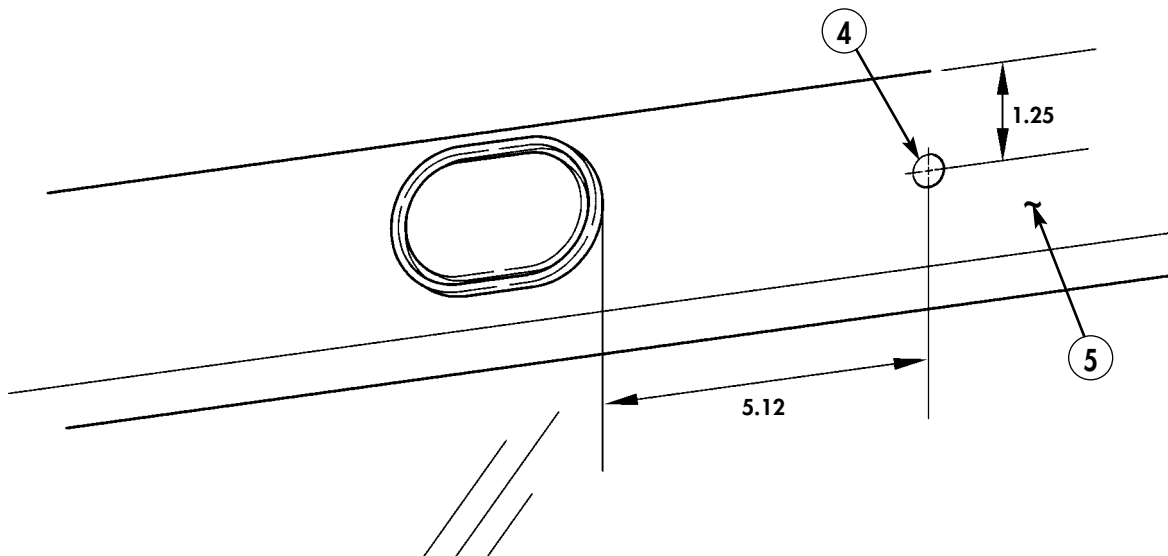
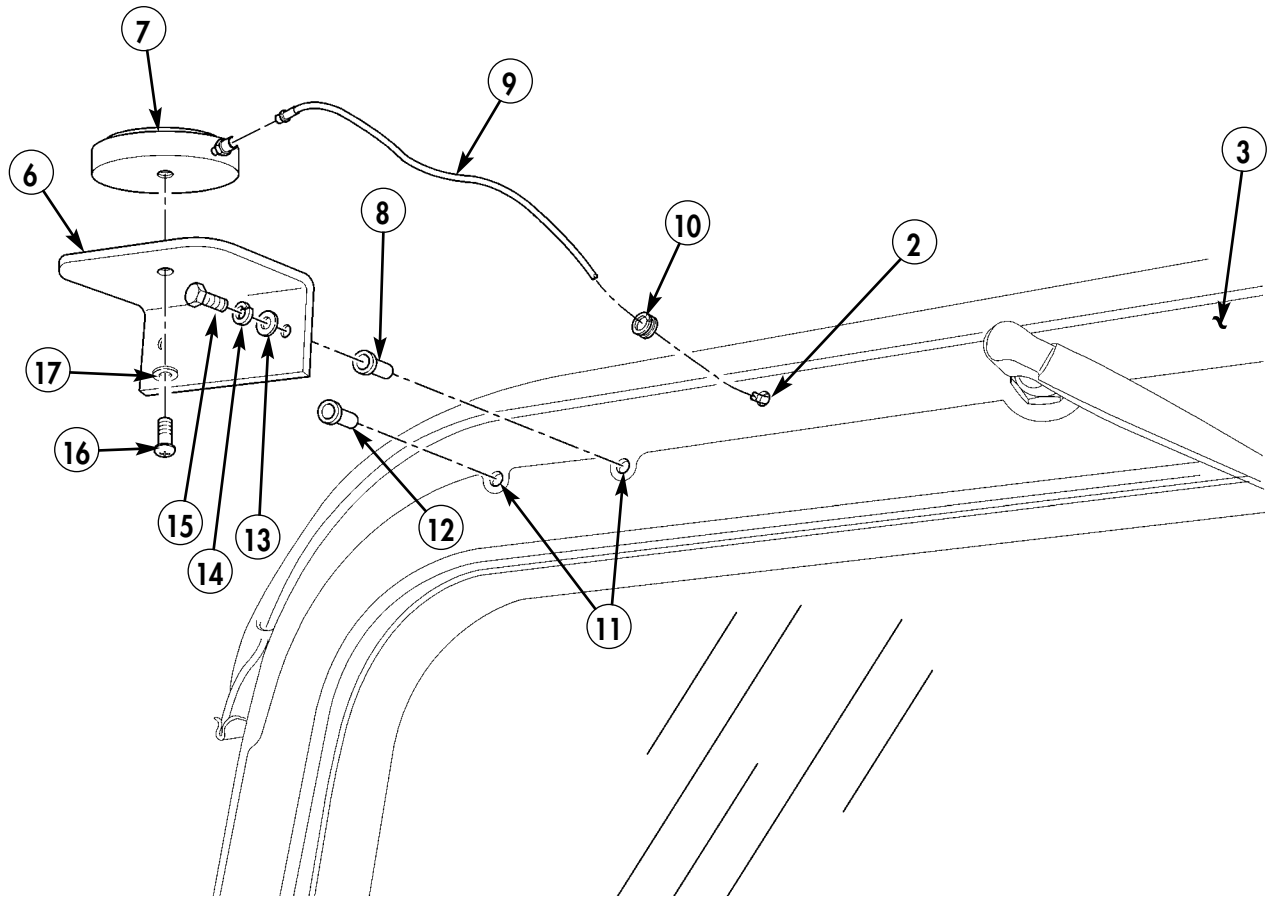

Figure 5-62.

- 17-4. Pull PLGR antenna cable (9) through hole (2) in outer right-side windshield frame (3).
- 17-5. Split one side of grommet (10), place on PLGR antenna cable (9), and insert grommet (10) in hole (2) in outer right-side windshield frame (3).
- 17-6. Install wellnuts (8) and (12) in holes (11).
- 17-7. Install PLGR antenna mount bracket (6) on outer right side windshield frame (3) with two lockwashers (13), washers (14), and capscrews (15).
- 17-8. Install PLGR antenna (7) on PLGR antenna mount bracket (6) with washer (17) and screw (16).
- 17-9. Attach PLGR antenna cable (9) to PLGR antenna (7).



- 6. PLGR ANTENNA MOUNT BRACKET - 12480578 - QTY. 1
- 7. PLGR ANTENNA - AT575-030 - QTY. 1
- 8. WELLNUT - 12339397-6 - QTY. 1
- 9. PLGR ANTENNA CABLE - 426-0141-050 - QTY. 1
- 10. GROMMET - MS35489-143 - QTY. 1
- 12. WELLNUT - 12339397-3 - QTY. 1
- 13. LOCKWASHER - MS35338-44 - QTY. 2
- 14. WASHER - 9414920 - QTY. 2
- 15. CAPSCREW - B1821BH025C125N - QTY. 2
- 16. SCREW - 160035 - QTY. 1
- 17. WASHER - 9417373 - QTY. 1

Figure 5-63.

- 17-10.** Split one side of grommet (10) and place on PLGR antenna cable (9).
- 17-11.** Insert PLGR antenna cable (9) and grommet (10) in hole (4) in inner right windshield frame (5).

NOTE

If sun visor kit has not been installed, perform steps 17-12 through 17-14. If sun visor has been installed, perform steps 17-15 and 17-16.

- 17-12.** Locate, mark, and drill one 0.390-in. diameter hole (21) in windshield frame (5).
- 17-13.** Install insert (22) in hole (21).
- 17-14.** Route PLGR antenna cable (9) along inner right windshield frame (5) with loop clamp (20), lockwasher (19), and capscrew (18).
- 17-15.** Remove capscrew (18) and lockwasher (19).
- 17-16.** Route PLGR antenna cable (9) along inner right windshield frame (5) with loop clamp (20), lockwasher (19), and capscrew (18).

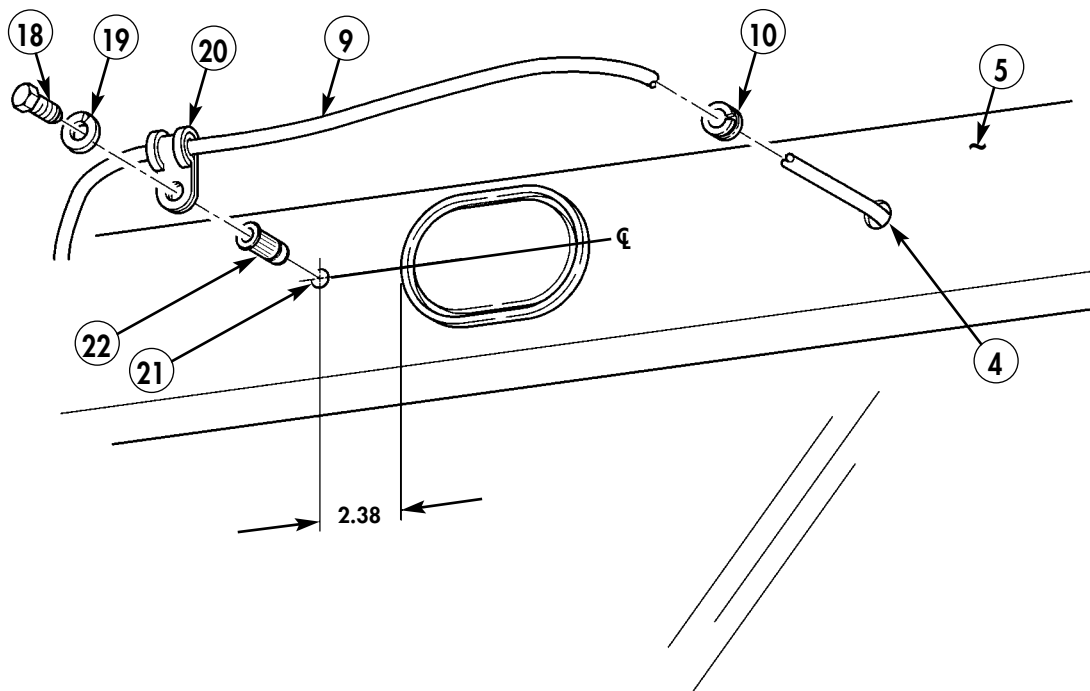

- 10.** GROMMET – MS35489-143 – QTY. 1
18. CAPSCREW – B1821BH025C100N – QTY. 1
19. LOCKWASHER – 120380 – QTY. 1
20. LOOP CLAMP – MS21333-96 – QTY. 1
22. INSERT – 12446871-2 – QTY. 1

Figure 5-64 .

- 17-17. Locate, mark, and drill two 0.147-in. diameter holes (27) in windshield center frame (28).
- 17-18. Route PLGR antenna cable (9) along windshield center frame (28) with two self-tapping screws (25), loop clamps (26) and (20), existing screw (23), and washer (24).

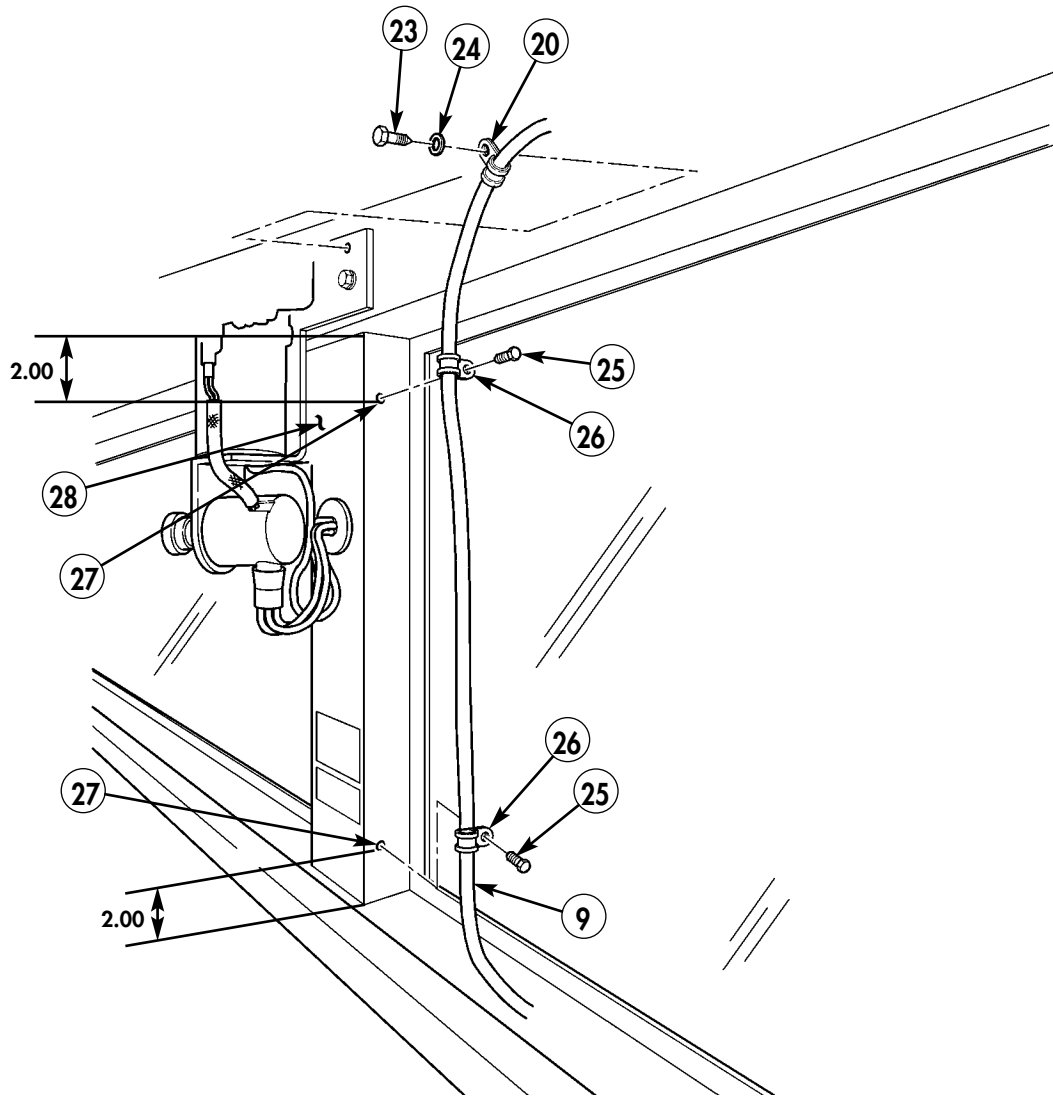

- 20. LOOP CLAMP – MS21333-96 – QTY. 1
- 25. SELF-TAPPING SCREW – 9421073 – QTY. 2
- 26. LOOP CLAMP – MS21333-65 – QTY. 2

Figure 5-65.

- 17-19. Locate, mark, and drill one 0.147-in. hole (35) in top of windshield frame (30).
- 17-20. Route PLGR antenna cable (9) on top of windshield frame (30) and secure with loop clamp (26) and self-tapping screw (25).
- 17-21. Route PLGR antenna cable (9) down through center access hole (29) of integrated rack (31), and coil excess antenna cable (9) under integrated rack (31).
- 17-22. Route PLGR power cable (33) from bracket (32) to right-side tunnel insulation (34).

NOTE

Loosen right-side tunnel insulation before performing step 17-23.
(Refer to TM 9-2320-280-20.)

- 17-23. Route PLGR power cable (33) under edge of right-side tunnel insulation (34) to 24V terminal bar at cab enclosure panel.

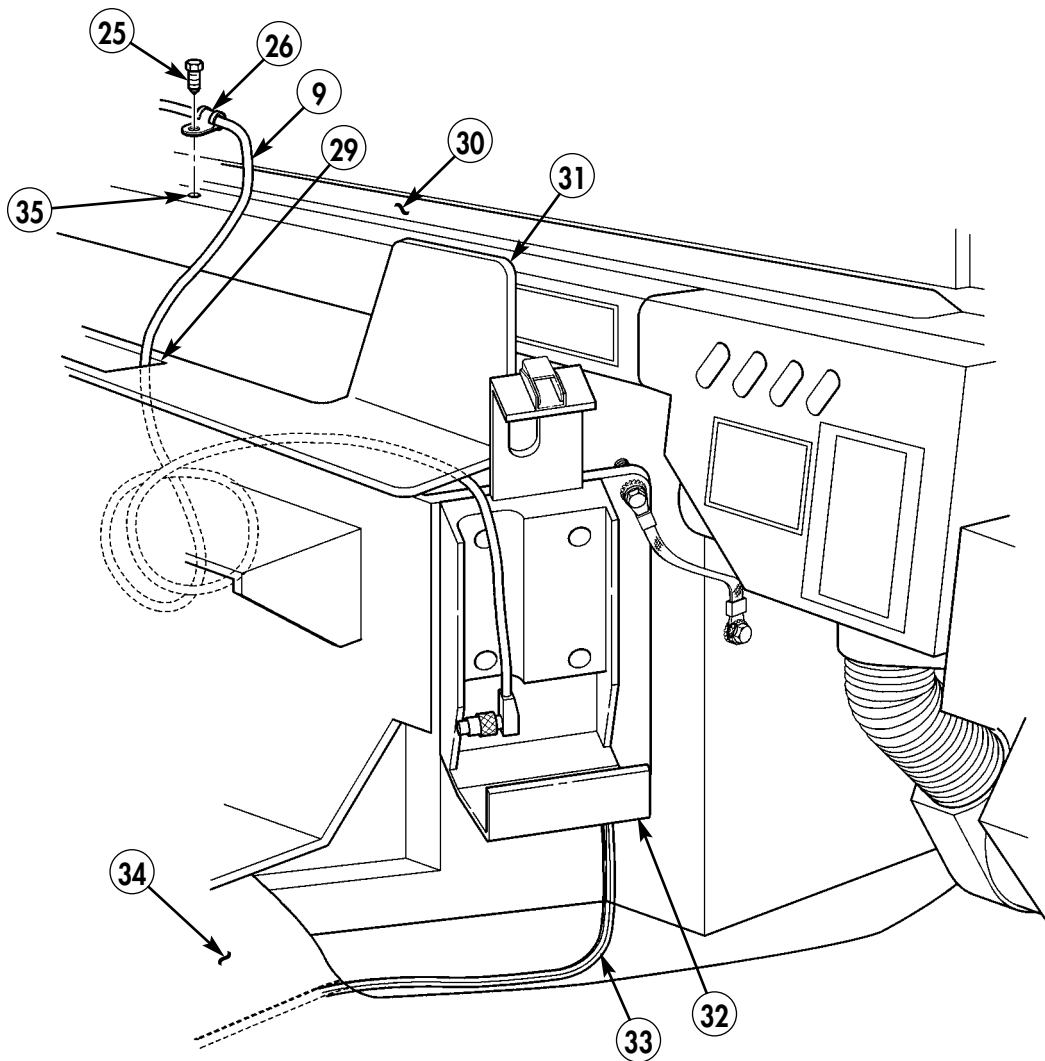

- 25. SELF-TAPPING SCREW - 9421073 - QTY. 1
- 26. LOOP CLAMP - MS21333-65 - QTY. 1
- 31. PLGR POWER CABLE - 9728558-10 - QTY. 1

Figure 5-66.

NOTE

PLGR power cable positive lead insulation is ribbed.

- 17-24. Attach shrink tubing (38) and terminal lugs (36) and (42) to PLGR power cable negative lead (41) and PLGR power cable positive lead (39). (Refer to TM 9-2320-280-20 for terminal connector repair.)
- 17-25. Attach PLGR power cable positive lead (39) to 24V terminal board (44) located on cab enclosure panel (45) with existing nut (37).
- 17-26. Attach PLGR power cable negative lead (41) to ground strap (43) located on cab enclosure panel (45) with existing nut (37).
- 17-27. Coil excess positive and negative power leads (39) and (41), place beneath ground strap (43), and secure with tiedown strap (40).

NOTE

Ensure all excess antenna cable is inside cab of vehicle.

- 17-28. Coil excess antenna cable and store under integrated rack using tiedown strap (40) as necessary. (Refer to figure 5-65.)
- 17-29. Install right-side tunnel insulation. (Refer to TM 9-2320-280-20.)

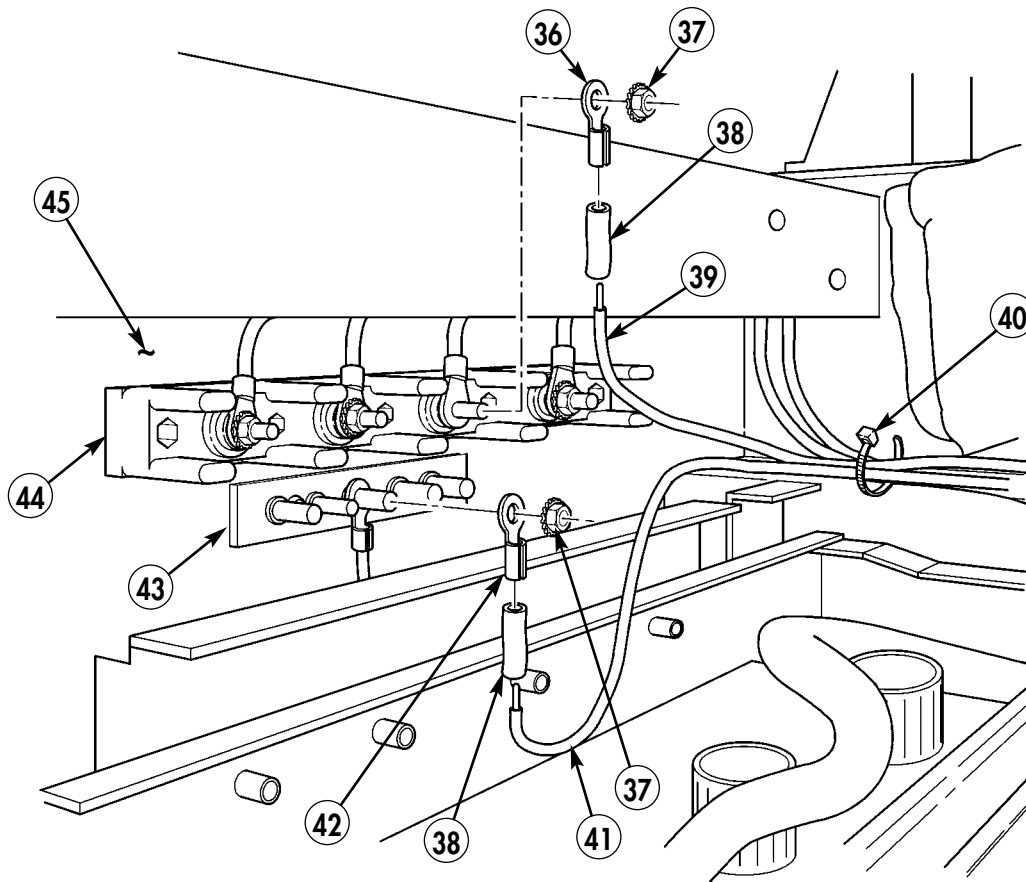

- 36. TERMINAL LUG – 7728780 – QTY. 1
- 38. SHRINK TUBING – MS23053/4-302-0 – QTY. A/R
- 40. TIEDOWN STRAP – MS3367-1-0 – QTY. A/R
- 42. TERMINAL LUG – 7728777 – QTY. 1

Figure. 5-67.

Section XVIII. EPLRS MOUNTING INSTALLATION

- 18-1. Remove two sections (3) from mounting plate (1) as shown.
- 18-2. Remove paint from vicinity of sixteen mounting holes (2) on mounting plate (1).

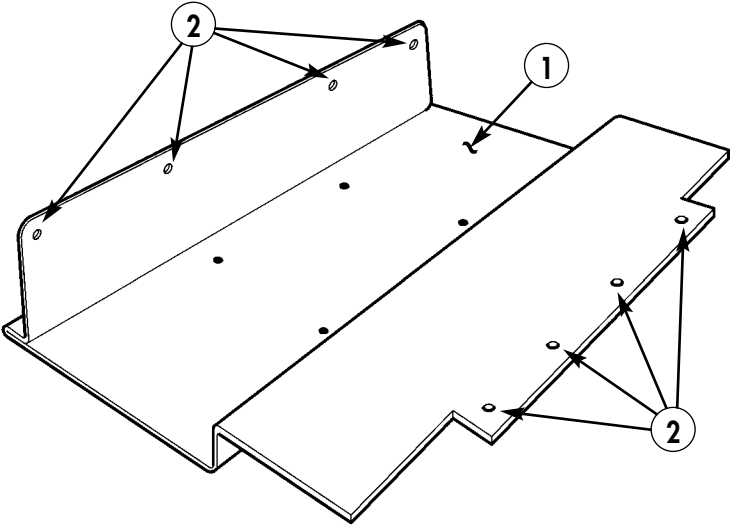
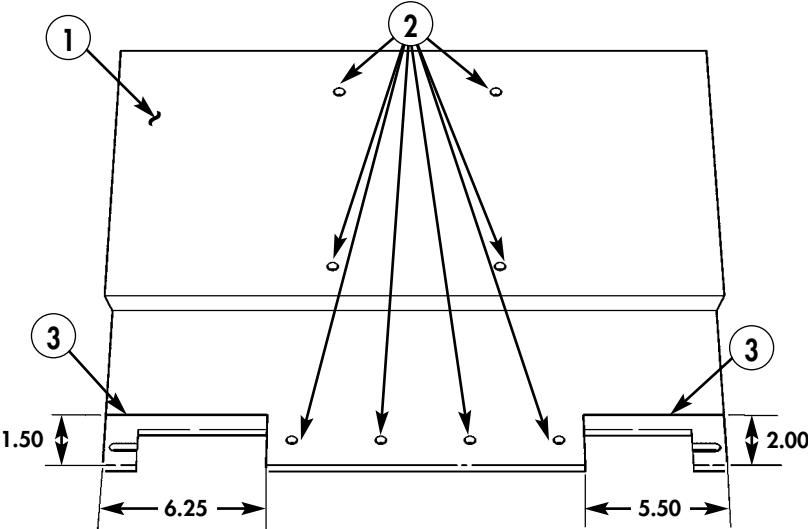

1. MOUNTING PLATE, EPLRS - A3046204 - QTY. 1

Figure 5-68.

NOTE

Procedure requires removal and reinstallation of left rear side rail, which may require assistance. (Refer to TM 9-2320-280-20.) Perform steps 18-3, 18-5, 18-6, 18-8, and 18-10 only for vehicles equipped with rear side rails.

- 18-3. Remove left rear side rail (4).
- 18-4. Using mounting plate (1) as template, locate, mark, and drill four 0.343-in. diameter holes (10) and four 0.281-in. diameter holes (16) in left rear wheelhouse (12).
- 18-5. Install left rear side rail (4). Do not tighten screws.
- 18-6. Using mounting plate (1) and left rear wheelhouse (12) as templates, drill four holes in left rear side rail (4) from underside of left rear wheelhouse (12).
- 18-7. Install resilient mount (8) on mounting plate (1) with four capscrews (7), eight lockwashers (6), and four nuts (9).
- 18-8. Remove paint from vicinity of eight mounting holes (16) and (10) on left rear wheelhouse (12). Apply anti-seize compound as required, and position mounting plate (1) between left side rail (4) and left rear wheelhouse (12). Align all holes.
- 18-9. Install mounting plate (1) on left rear wheelhouse (12) with four capscrews (5), lockwashers (14), eight washers (15), four nuts (13), capscrews (7), eight lockwashers (6), four spacers (11), and nuts (9).
- 18-10. Tighten all left side rail screws.

- 5. CAPSCREW – B1821BH025C125N – QTY. 4
- 6. LOCKWASHER – MS45904-72 – QTY. 16
- 7. CAPSCREW – B1821BH031C100N – QTY. 8
- 8. RESILIENT MOUNT – MT-6146/VSQ-1 – QTY. 1
- 9. NUT – 9417954 – QTY. 8
- 11. SPACER – A3046313 – QTY. 4
- 13. NUT – 9419143 – QTY. 4
- 14. LOCKWASHER – MS45904-68 – QTY. 4
- 15. WASHER – 2436161 – QTY. 8

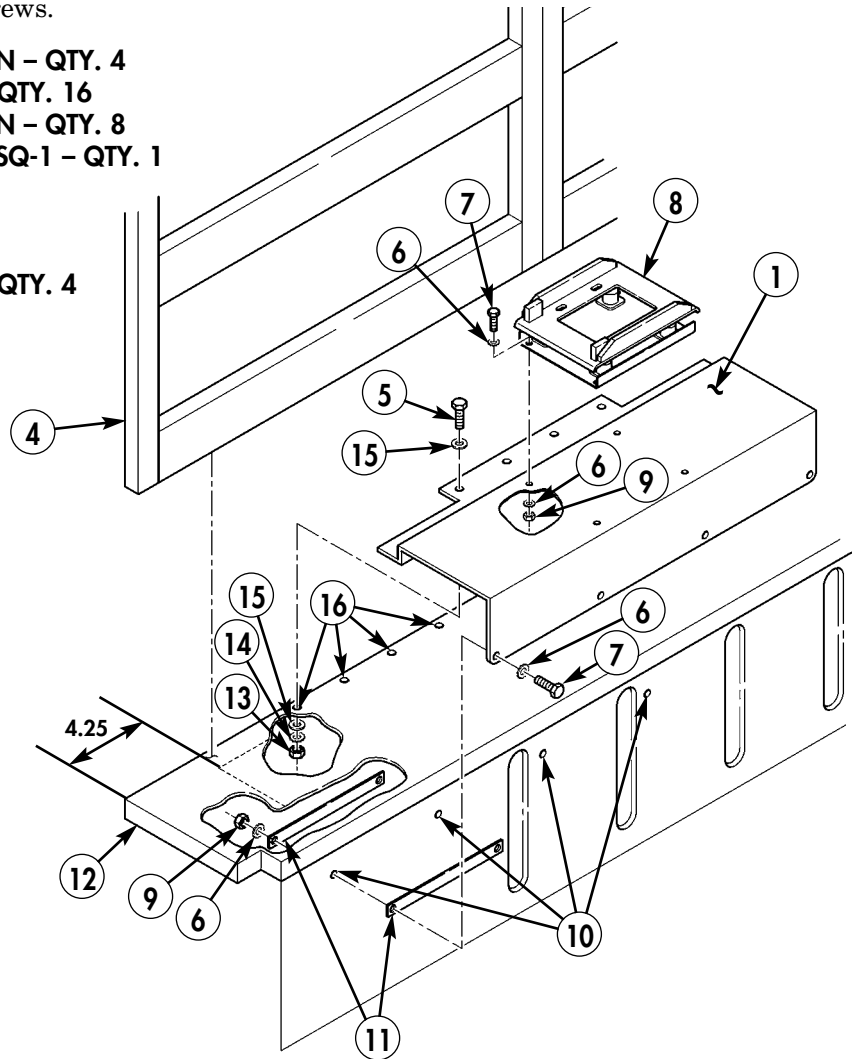

Figure 5-69.

Section XIX. EPLRS URO (USER READOUT) INSTALLATION

NOTE

- Ensure all mounting holes are on the flat surface of cargo floor raised ribs.
- SINCGARS model AN/VRC-92F shown.

- 19-1.** Locate, mark, and drill four 0.147-in. holes (6) on tunnel (4) in front of integrated rack (3) and centered between loudspeakers (5).
- 19-2.** Install URO bracket (1) on tunnel (4) with four self-tapping screws (2) and spacers (7).

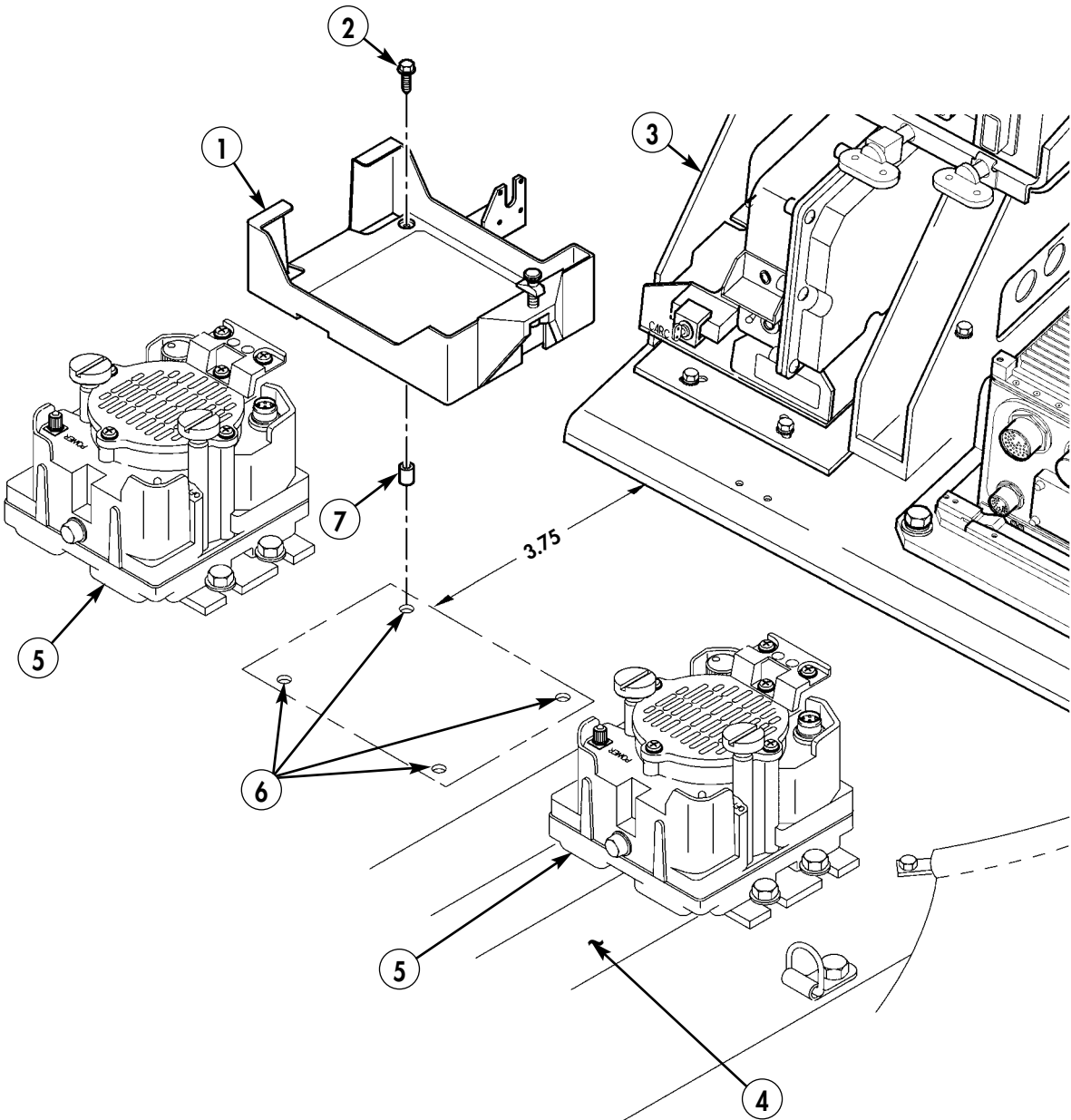

- 1. URO (USER READOUT) BRACKET – A3006206 – QTY. 1
- 2. SELF-TAPPING SCREW – 9426634 – QTY. 4
- 7. SPACER – 92510A318 – QTY. 4

Figure 5-70.

Section XX. EPLRS AND SINGARS ANTENNA INSTALLATION (TWO-MAN VEHICLES)

NOTE

Perform following procedures for a two-man vehicle configuration only.

- 20-1. Enlarge four holes (2) to 0.343-in. diameter, and remove paint from vicinity of four mounting holes (2) on antenna base bracket (1).

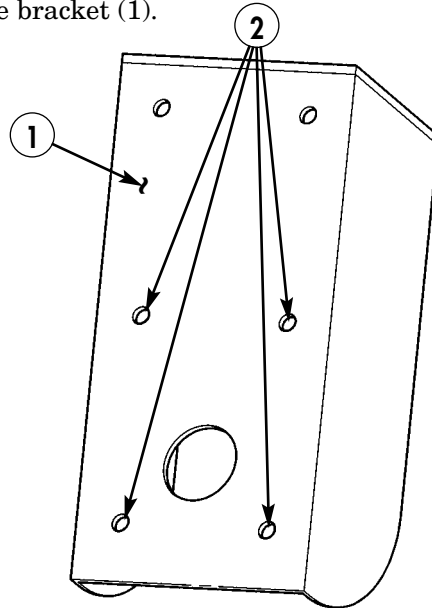
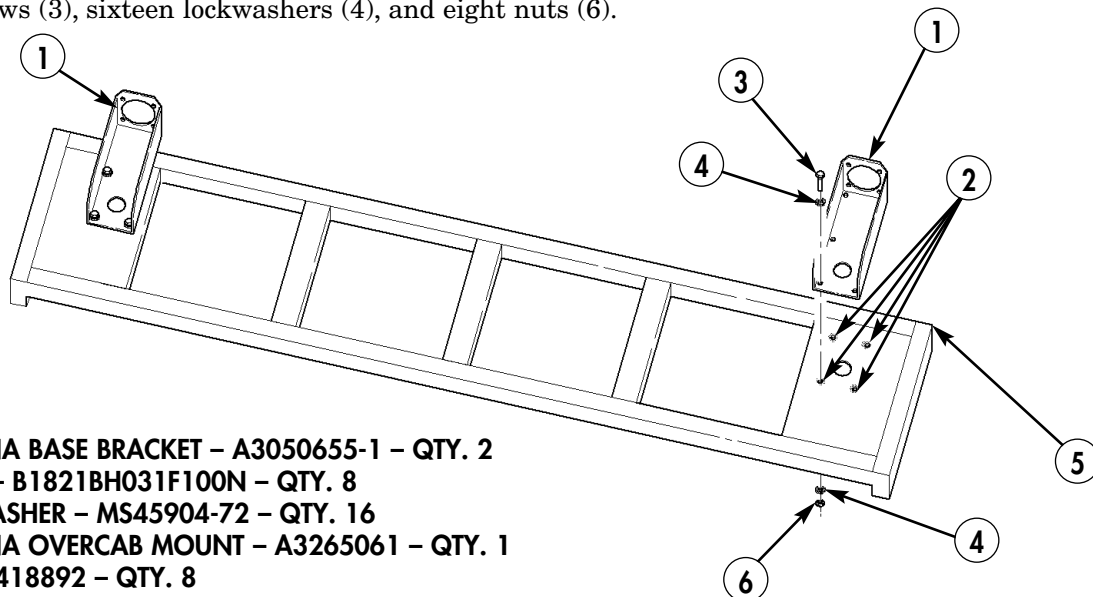

Figure 5-71.

NOTE

Perform steps 20-2 and 20-3 on left and right side of antenna overcab mount.

- 20-2. Using antenna base bracket (1) as template, align access holes of antenna base bracket (1) and antenna overcab mount (5). Mark and drill four 0.343-in. diameter holes (2) in antenna overcab mount (5).
- 20-3. Remove paint from vicinity of four mounting holes (2) on antenna overcab mount (5). Apply anti-seize compound as required.
- 20-4. Install two antenna base brackets (1) on front side of antenna overcab mount (5) with eight screws (3), sixteen lockwashers (4), and eight nuts (6).



- 1. ANTENNA BASE BRACKET - A3050655-1 - QTY. 2
- 3. SCREW - B1821BH031F100N - QTY. 8
- 4. LOCKWASHER - MS45904-72 - QTY. 16
- 5. ANTENNA OVERCAB MOUNT - A3265061 - QTY. 1
- 6. NUT - 9418892 - QTY. 8

Figure 5-72.

20-5. Remove paint from vicinity of sixteen mounting holes (9) on left overhead rail (7) and right overhead rail (8). Apply anti-seize compound as required.

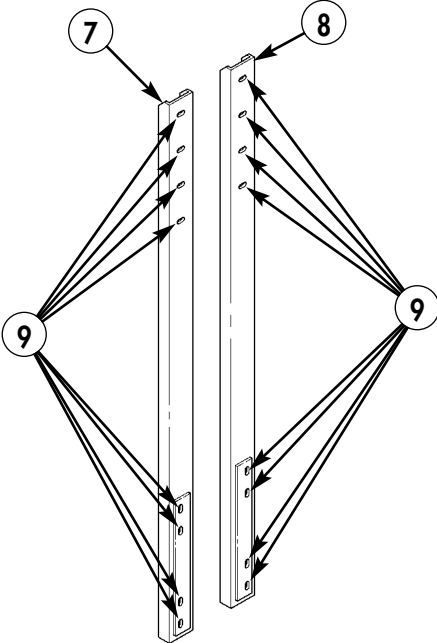
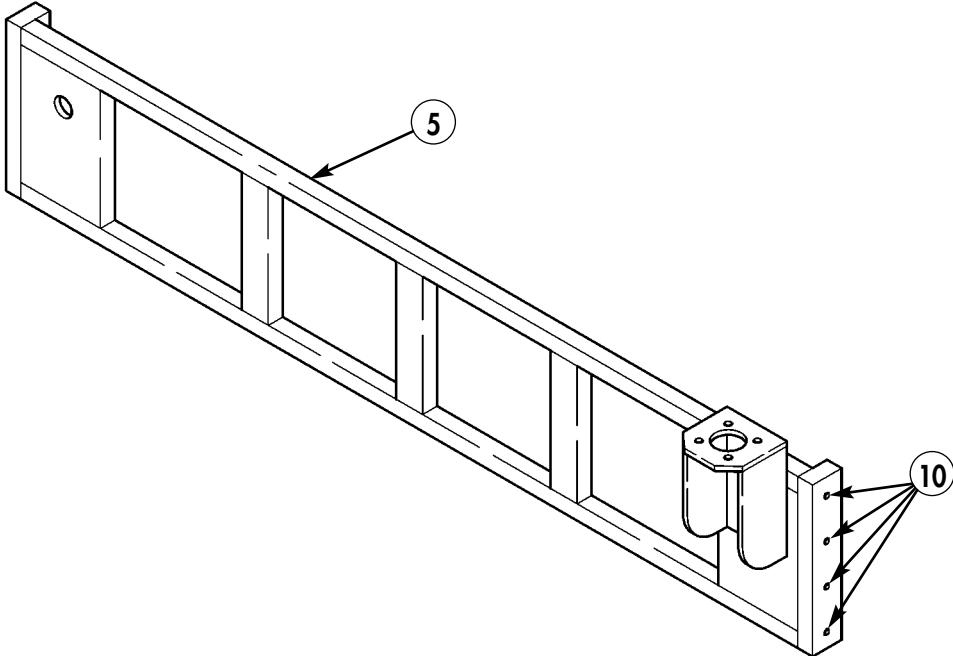

Figure 5-73.

NOTE

Perform step 20-6 on both sides of antenna overcab mount.

20-6. Remove paint from vicinity of four mounting holes (10) on antenna overcab mount (5). Apply anti-seize compound as required. Repeat for opposite side.



- 7. LEFT OVERHEAD RAIL – A3265060-001 – QTY. 1
- 8. RIGHT OVERHEAD RAIL – A3265060-002 – QTY. 1

Figure 5-74.

- 20-7. Remove and discard four existing bolts from left and right B-pillars.
- 20-8. Remove paint from vicinity of four holes (11) on left B-pillar mounting (12). Apply anti-seize compound as required.
- 20-9. Install left overhead rail (7) on left B-pillar mounting (12) with four capscrews (13) and washers (14). Do not tighten capscrews (13).

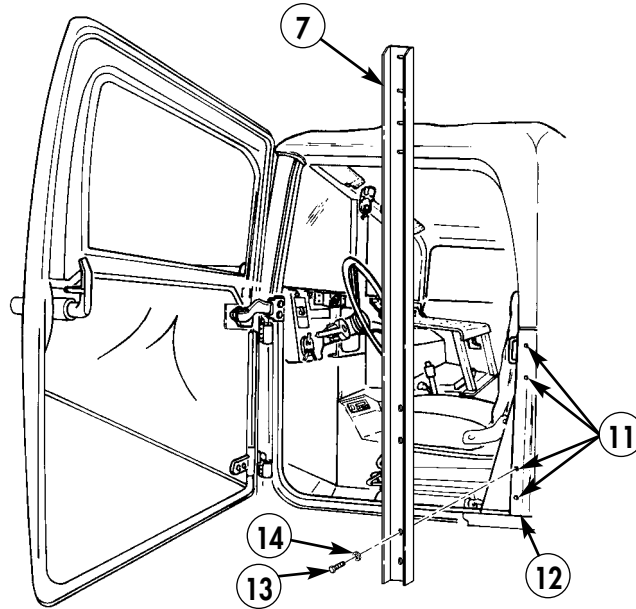
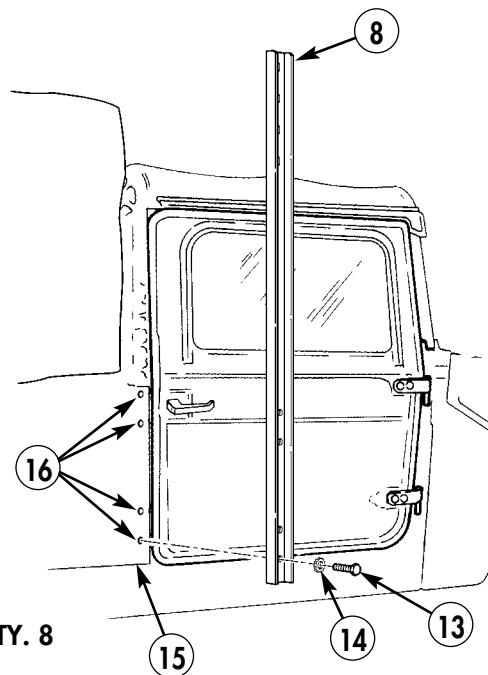

Figure 5-75.

- 20-10. Remove paint from vicinity of four holes (16) on right side of vehicle B-pillar (15). Apply anti-seize compound as required.
- 20-11. Install right overhead rail (8) on right B-pillar mounting (15) with four capscrews (13) and washers (14). Do not tighten capscrews (13).



- 13. CAPSCREW - B1821BH025C138N - QTY. 8
- 14. WASHER - 2436161 - QTY. 8

Figure 5-76.

20-12. Install antenna overcab mount (5) on left overhead rail (7) and right overhead rail (8) with six capscrews (17) and six lockwashers (18), omitting one screw and lockwasher (third from top) from both sides. Tighten lower left rail and right rail capscrews (13). (Refer to figures 5-74 and 5-75.)

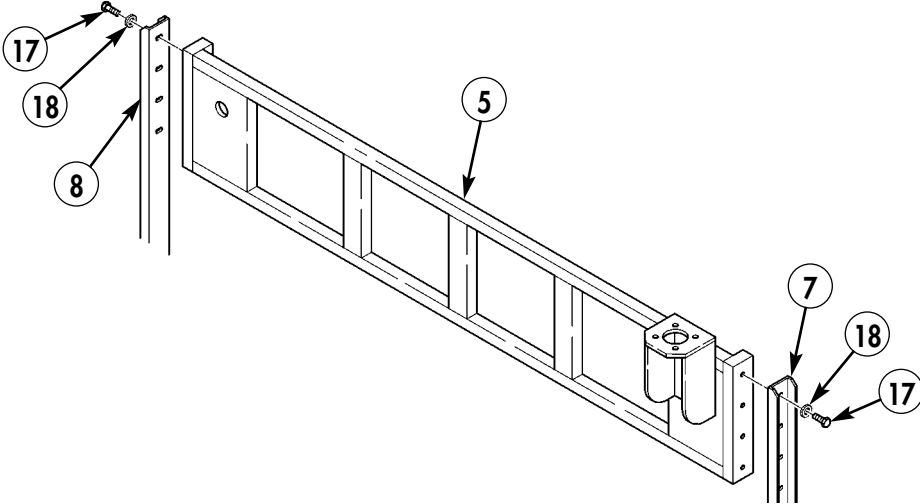
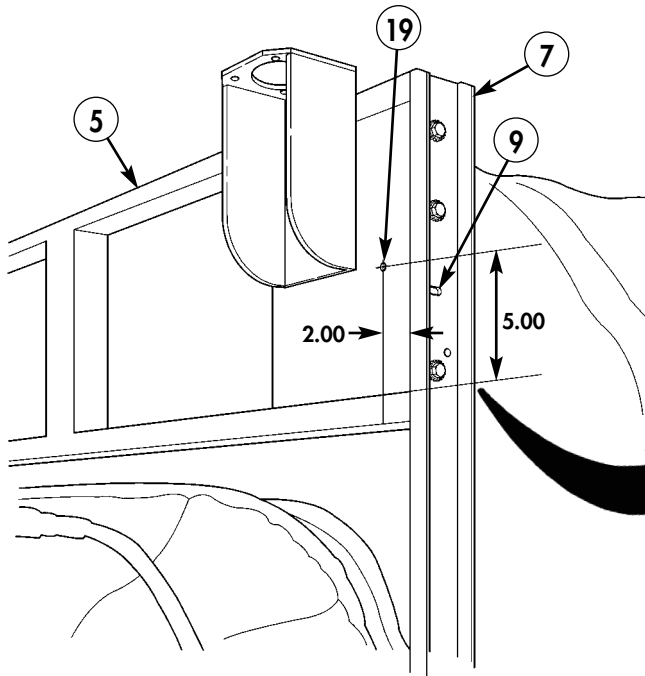

Figure 5-77.

- 20-13. Remove paint from vicinity of left overhead rail hole (9). Apply anti-seize compound as required.
- 20-14. Fabricate ground strap (22) from 6-in. length of braided wire and two terminal lugs.
- 20-15. Install ground strap (22) on left overhead rail (7) with capscrew (17) and two lockwashers (18).
- 20-16. Locate, mark, and drill one 0.281-in. diameter hole (19) in antenna overcab mount (5).
- 20-17. Remove paint from vicinity of antenna overcab mount hole (19). Apply anti-seize compound as required.
- 20-18. Install ground strap (22) on antenna overcab mount (5) with capscrew (23), two lockwashers (18), washer (20), and nut (21).
- 20-19. Repeat steps 20-13 through 20-18 for right side.



- 17. CAPSCREW – B1821BH025C100N – QTY. 8
- 18. LOCKWASHER – MS45904-71 – QTY. 14
- 20. WASHER – 2436161 – QTY. 2
- 21. NUT – 9419143 – QTY. 2
- 22. GROUND STRAP
 - BRAIDED WIRE – AA59569F30T0375 – QTY. A/R
 - TERMINAL LUG – MS20659-141 – QTY. 4
- 23. CAPSCREW – B1821BH025C075N – QTY. 2

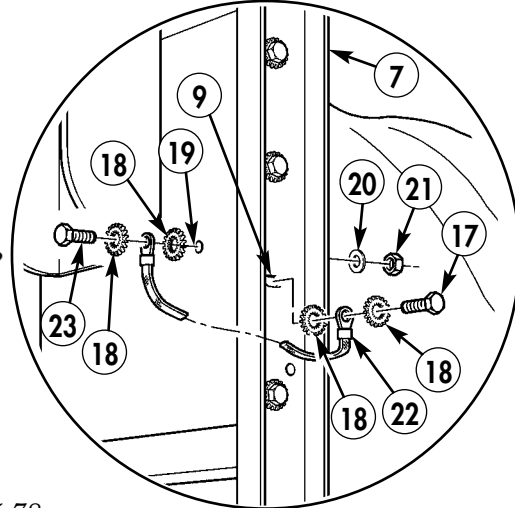
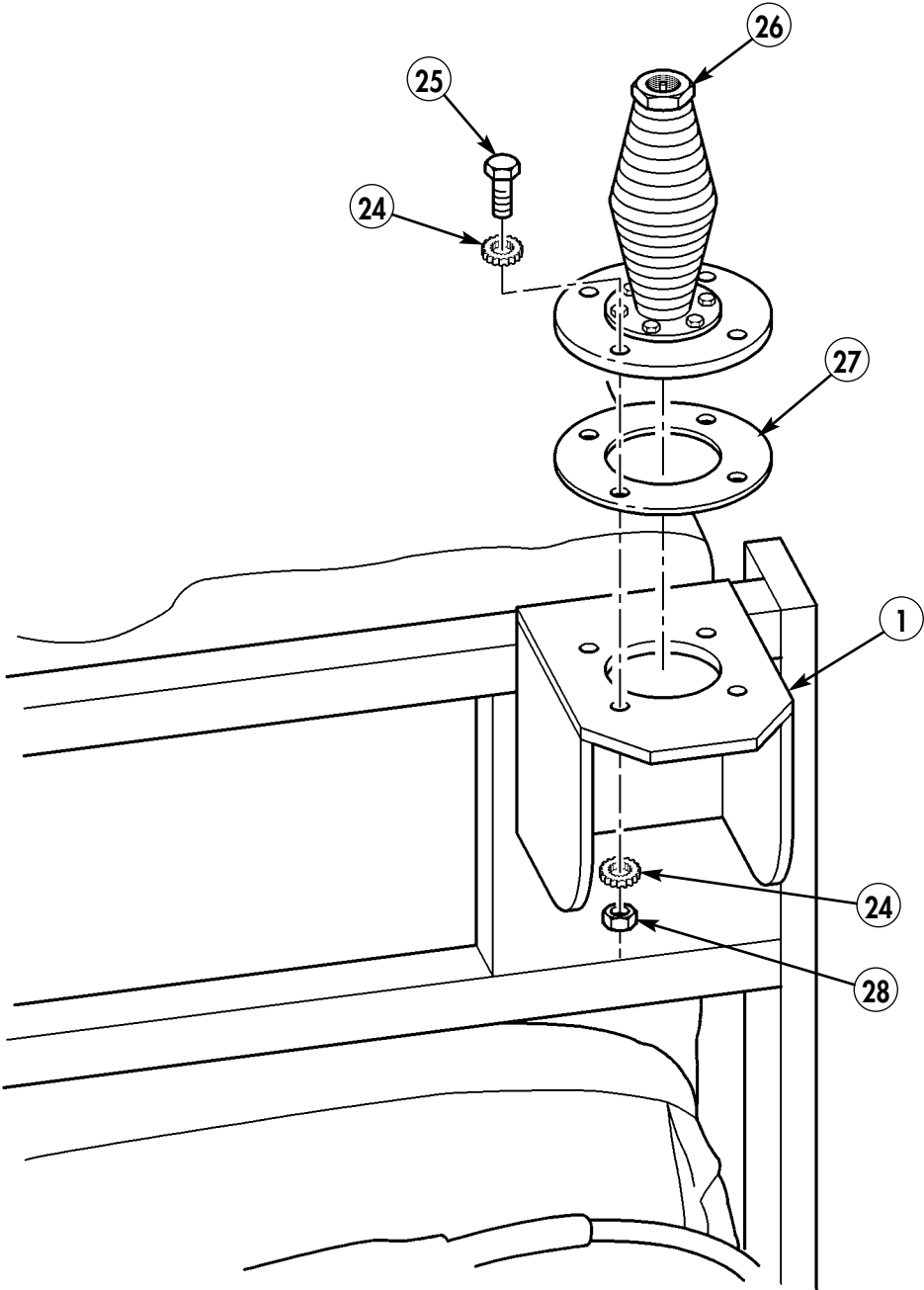

Figure 5-78.

20-20. Install antenna base (26) on antenna base bracket (1) with four capscrews (25), eight lockwashers (24), gasket (27), and four nuts (28).



- 24. LOCKWASHER - MS45904-76 - QTY. 8
- 25. CAPSCREW - B1821BH038C150N - QTY. 4
- 26. ANTENNA - A3005031 - QTY. 1
- 27. GASKET - A3013655-1 - QTY. 1
- 28. NUT - 13218E0320-293 - QTY. 4

Figure 5-79.

- 20-21. Position antenna with base (29) and gasket (33) on antenna bracket (1) and feed existing ground strap through antenna base bracket (1).
- 20-22. Attach antenna with base (29) to antenna base bracket (1) with four screws (30), eight lockwashers (31), and four nuts (32).

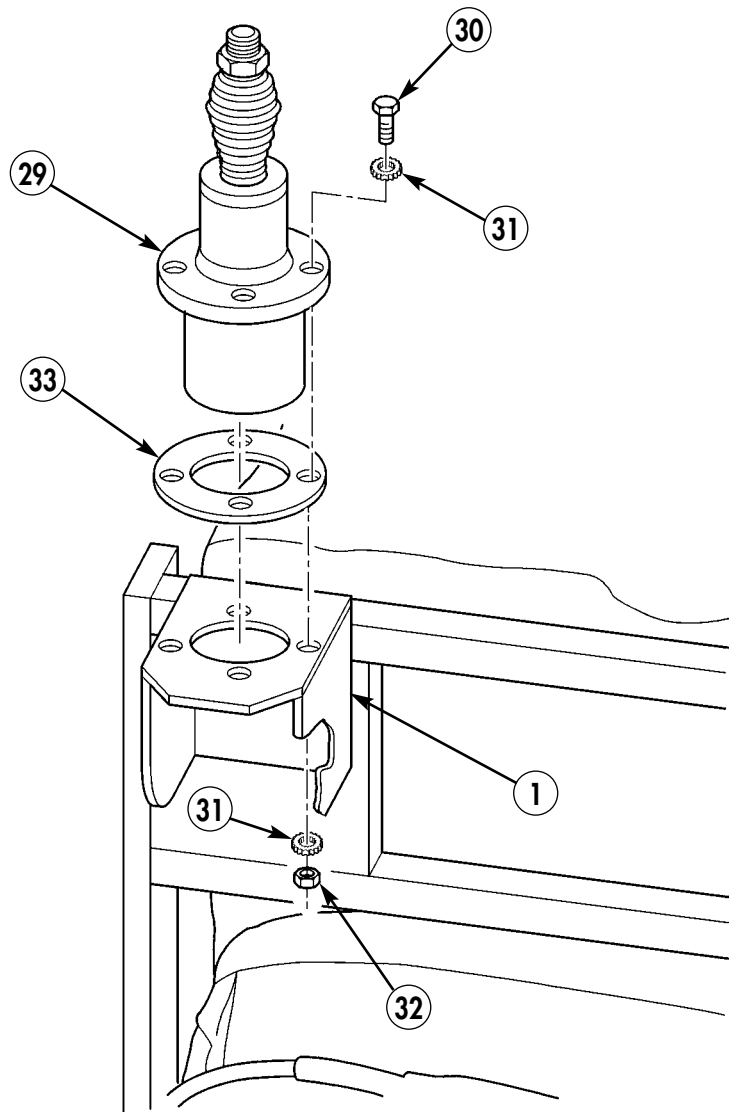

- 29. ANTENNA – A3017889-2 – QTY. 1
- 30. SCREW – MS35307-365 – QTY. 4
- 31. LOCKWASHER – MS45904-72 – QTY. 8
- 32. NUT – 13218E0320-293 – QTY. 4
- 33. GASKET – A3013655-1 – QTY. 1

Figure 5-80.

- 20-23. Attach upper antenna element (34) to lower antenna element (36).
- 20-24. Attach antenna assembly to antenna base (29).
- 20-25. Attach fiber rope assembly (35) to upper antenna element (34).
- 20-26. Secure lower antenna element (36) to antenna base (29) with lockwire (37).

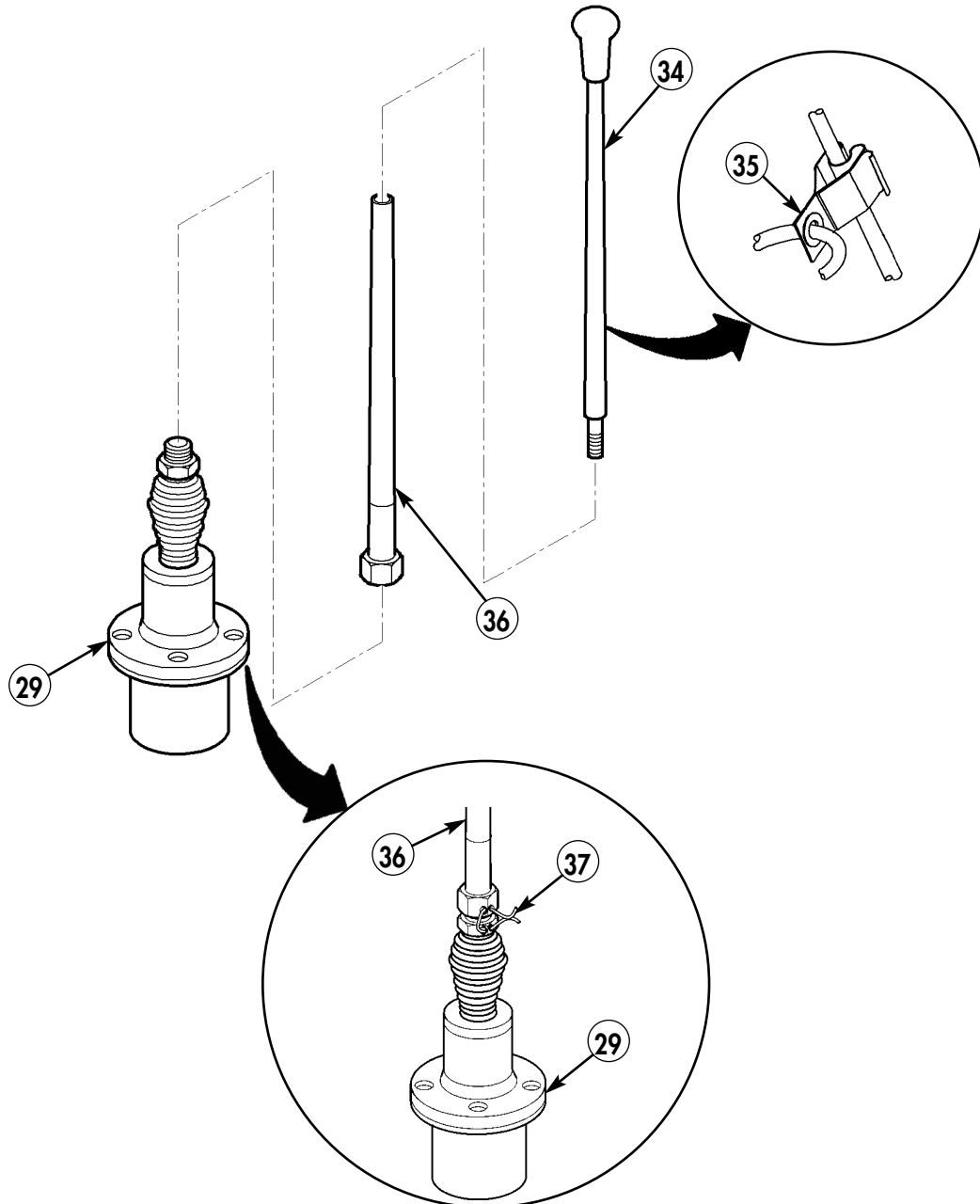

- 34. UPPER ANTENNA ELEMENT - A3017901-2 - QTY. 1
- 35. FIBER ROPE ASSEMBLY - A3167672-1 - QTY. 1
- 36. LOWER ANTENNA ELEMENT - A3018230-1 - QTY. 1
- 37. LOCKWIRE - MS20995C32 - QTY. A/R

Figure 5-81.

Section XXI. EPLRS CABLES INSTALLATION (TWO-MAN VEHICLES)

NOTE

- Loosen right-side tunnel insulation before performing step 21-1. (Refer to TM 9-2320-280-20.)
- Perform following procedures for two-man vehicle configuration only.

- 21-1. Route power cable (15) under right-side tunnel insulation towards terminal board. (Refer to figure 5-81.)
- 21-2. Attach heat shrink tubing (3) and two terminal lugs (1) and (8) to power cable negative lead (7) and power cable positive lead (4). (Refer to TM 9-2320-280-20 for terminal connector repair.)
- 21-3. Connect power cable positive lead (4) to 24V terminal board (10) located on cab enclosure panel (11) with existing nut (2).
- 21-4. Connect power cable negative lead (7) to ground strap (9) located on cab enclosure panel (11) with existing nut (6). Secure leads together with tiedown strap (5).
- 21-5. Secure right-side tunnel insulation. (Refer to TM 9-2320-280-20.)

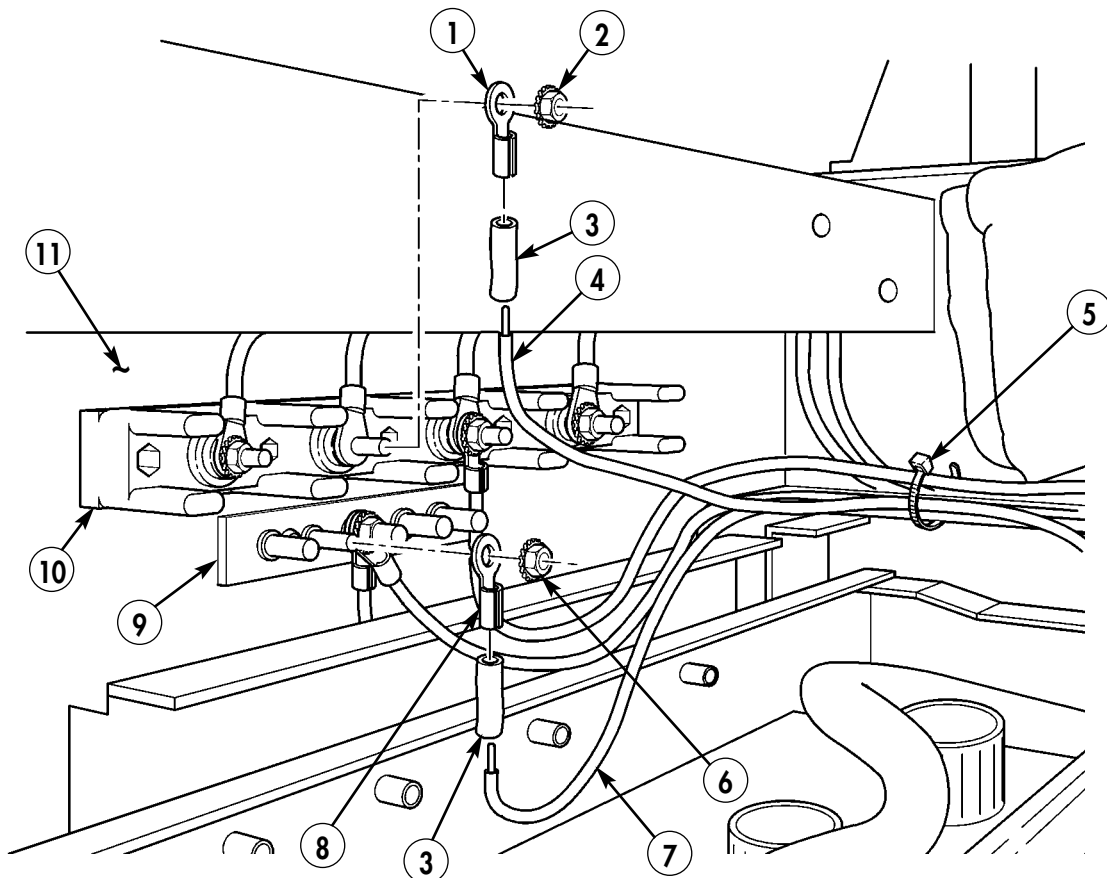

1. TERMINAL LUG - 7728780 - QTY. 1
3. SHRINK TUBING - MS23053/4-302-0 - QTY. A/R
5. TIEDOWN STRAP - MS3367-1-0 - QTY. A/R
8. TERMINAL LUG - 7728777 - QTY. 1

Figure 5-82.

NOTE

- Loosen left-side tunnel insulation before performing steps 21-6 through 21-8. (Refer to TM 9-2320-280-20.)
- SINGARS model AN/VRC-92F shown.
- Previously routed cables are not shown for clarity.

- 21-6.** Route INC-EPUU cable (12) from integrated rack (14) down through center access hole (13) and under left-side tunnel insulation (19) towards rear of vehicle.
- 21-7.** Route power cable (15) forward and under integrated rack (14) and under left-side tunnel insulation (19) towards rear of vehicle.
- 21-8.** Route URO extension cable (18) towards URO bracket (17) between loudspeakers (16) and connect to URO bracket (17) with four screws (20), lockwashers (21), and nuts (22). Route remaining URO extension cable (18) under left-side tunnel insulation (19) and towards rear of vehicle.
- 21-9.** Secure left-side tunnel insulation (19). (Refer to TM 9-2320-280-20.)

12. INC-EPUU CABLE – A3279383-3 – QTY. 1

15. EPLRS POWER CABLE – A3004939 – QTY. 1

18. URO EXTENSION CABLE – A3005328 – QTY. 1

20. SCREW – 9417875 – QTY. 4

21. LOCKWASHER – 131043 – QTY. 4

22. NUT 116002 – QTY. 4

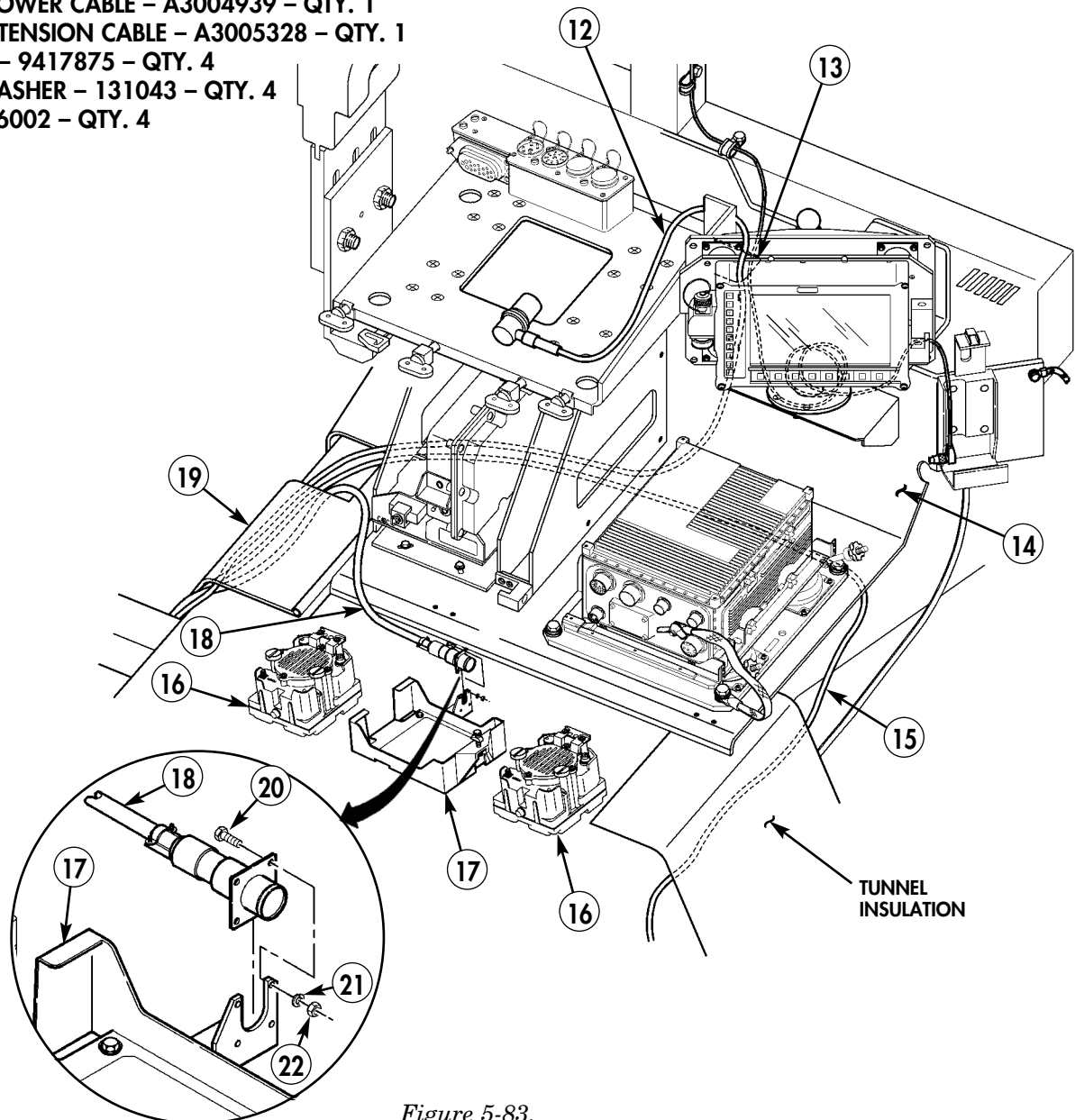
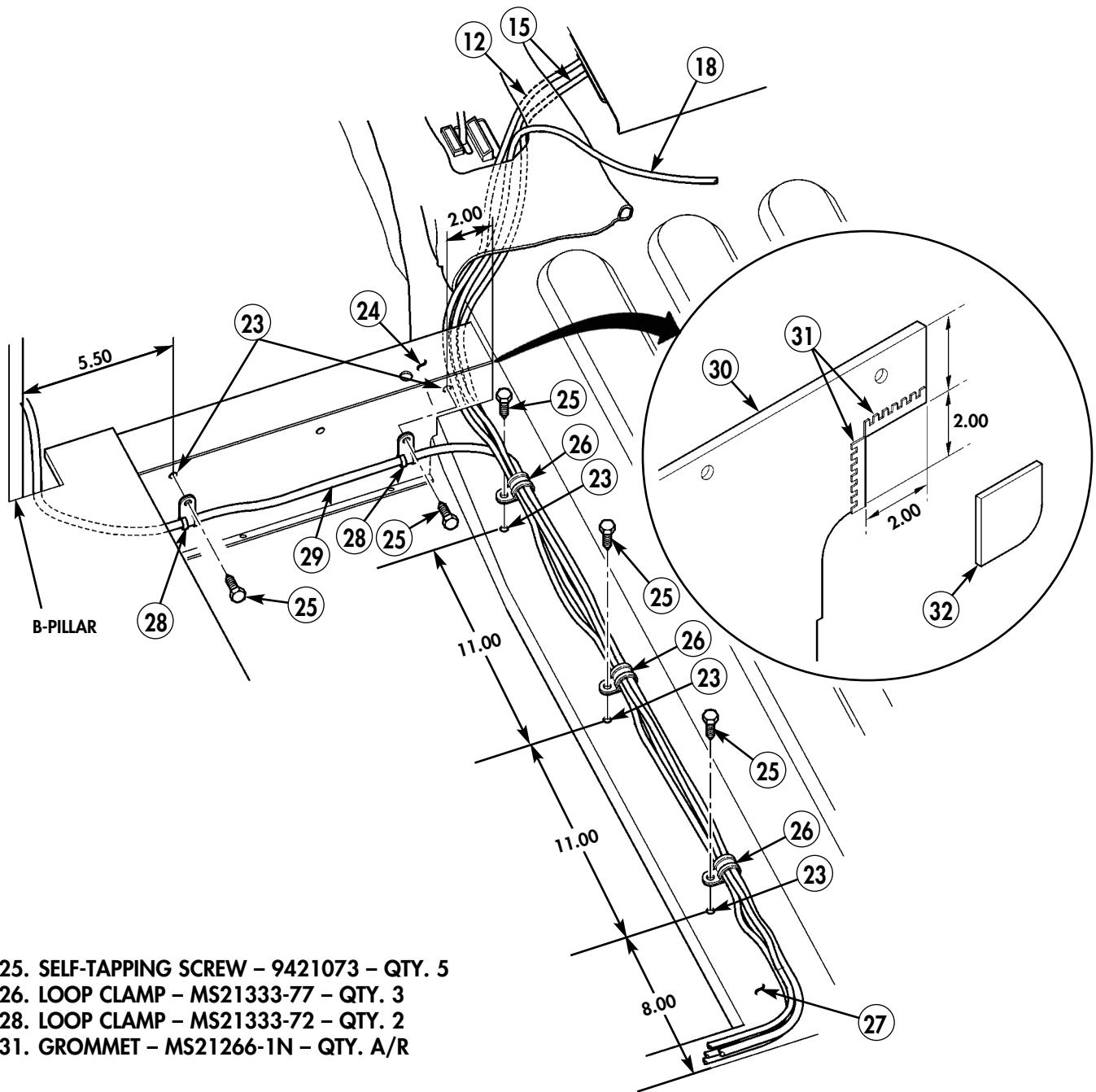

Figure 5-83.

NOTE

Perform step 21-10 for vehicles with left rear cab enclosure panel only.

- 21-10. Cut 2x2 in. section (32) from left rear cab enclosure panel (30). Install grommet (31). Reinstall cab enclosure panel (30). (Refer to TM 9-2320-280-20.)
- 21-11. Locate, mark, and drill five 0.147-in. holes (23) along tunnel edge (27) and rear of left B-beam (24).
- 21-12. Route INC-EPUU cable (12), URO extension cable (18), and power cable (15) rearward under B-beam (24) and along tunnel edge (27).
- 21-13. Route antenna cable (29) along rear of left B-beam (24) and secure with two loop clamps (28) and self-tapping screws (25).
- 21-14. Route INC-EPUU cable (12), URO extension cable (18), power cable (15), and antenna cable (29) rearward along tunnel edge (27) and secure with three clamps (26) and self-tapping screws (25).



- 25. SELF-TAPPING SCREW - 9421073 - QTY. 5
- 26. LOOP CLAMP - MS21333-77 - QTY. 3
- 28. LOOP CLAMP - MS21333-72 - QTY. 2
- 31. GROMMET - MS21266-1N - QTY. A/R

Figure 5-84.

NOTE

- If soft top has been installed, roll back to allow clearance for routing of antenna cable in steps 21-16 through 21-19.
- Lay out all cables in their approximate positions before clamps are installed. This will minimize cable length, and ensure all slack is taken out of all cables from front of vehicle to rear.
- Excess slack in all cables will be stored under EPLRS mount assembly.
- It may be necessary to drill one 0.281-in. diameter hole in right side of antenna base bracket for antenna cable clamp. (Refer to figure 5-83.)

- 21-15.** Locate, mark, and drill one 0.281-in. diameter hole (40) in left overhead rail (39).
- 21-16.** Route antenna cable (29) through hole (38) in overcab mount (34) and antenna base bracket (36) and connect to antenna (35).
- 21-17.** Install grommet (37) in antenna base bracket (36) and overcab mount (34).
- 21-18.** Secure antenna cable (29) to left overhead rail (39) and antenna base bracket (36) with two loop clamps (41), capscrews (33), lockwashers (42), and nuts (43).
- 21-19.** Route antenna cable (29) down along left overhead rail (39) and secure with loop clamp (41) and existing screw (44).
- 21-20.** Route antenna cable (29) to B-beam.

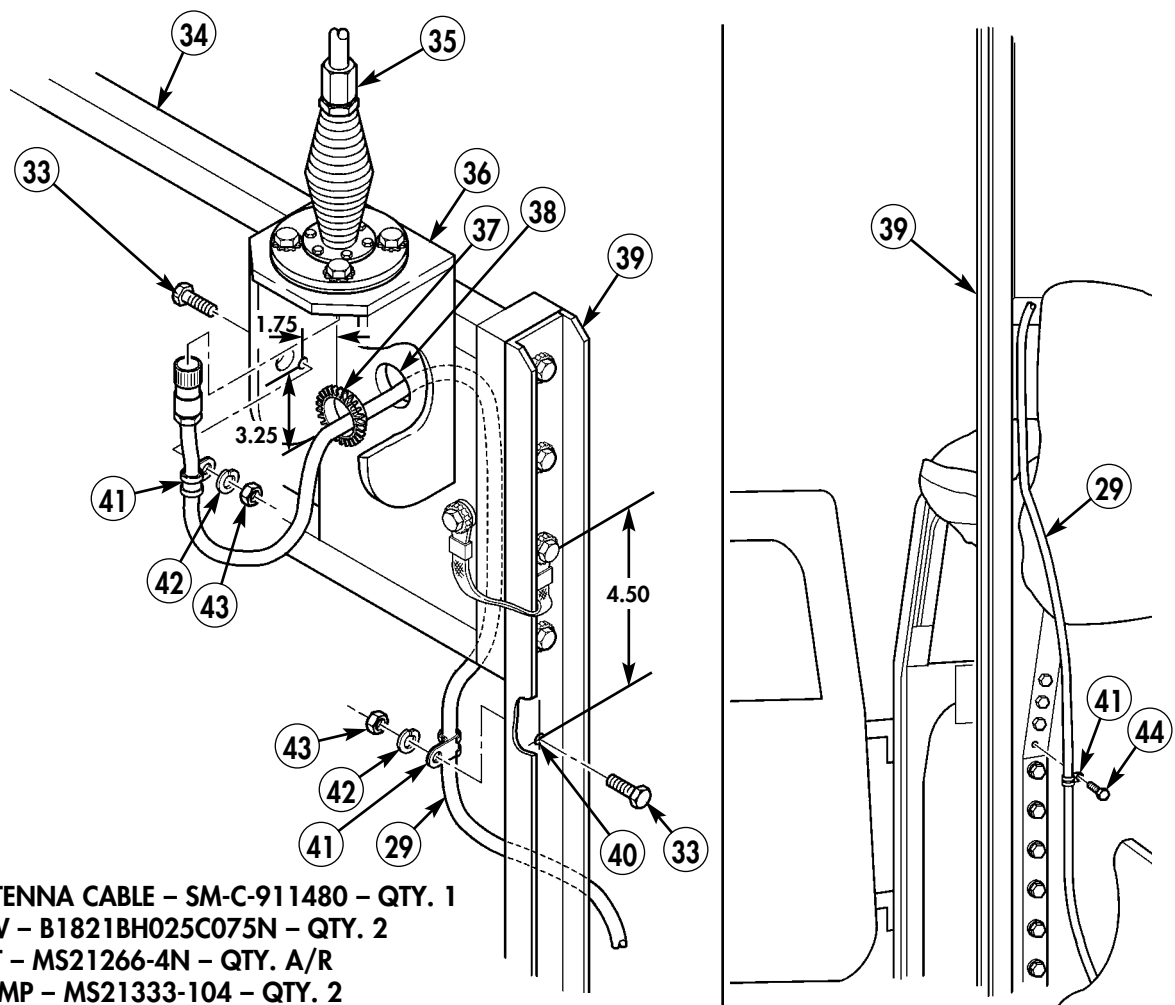

- 29.** EPLRS ANTENNA CABLE – SM-C-911480 – QTY. 1
33. CAPSCREW – B1821BH025C075N – QTY. 2
37. GROMMET – MS21266-4N – QTY. A/R
41. LOOP CLAMP – MS21333-104 – QTY. 2
42. LOCKWASHER – MS35338-44 – QTY. 2
43. NUT – 9419143 – QTY. 2

Figure 5-85.

- 21-21. Locate, mark, and drill four 0.147-in. holes (47) in left rear wheelhouse (46).
- 21-22. Locate, mark, and drill one 1.875-in. hole (49) in fixed rear door (48).
- 21-23. Locate, mark, and drill three 0.218-in. holes (50) on rear inside lip of left rear seat back support (51).

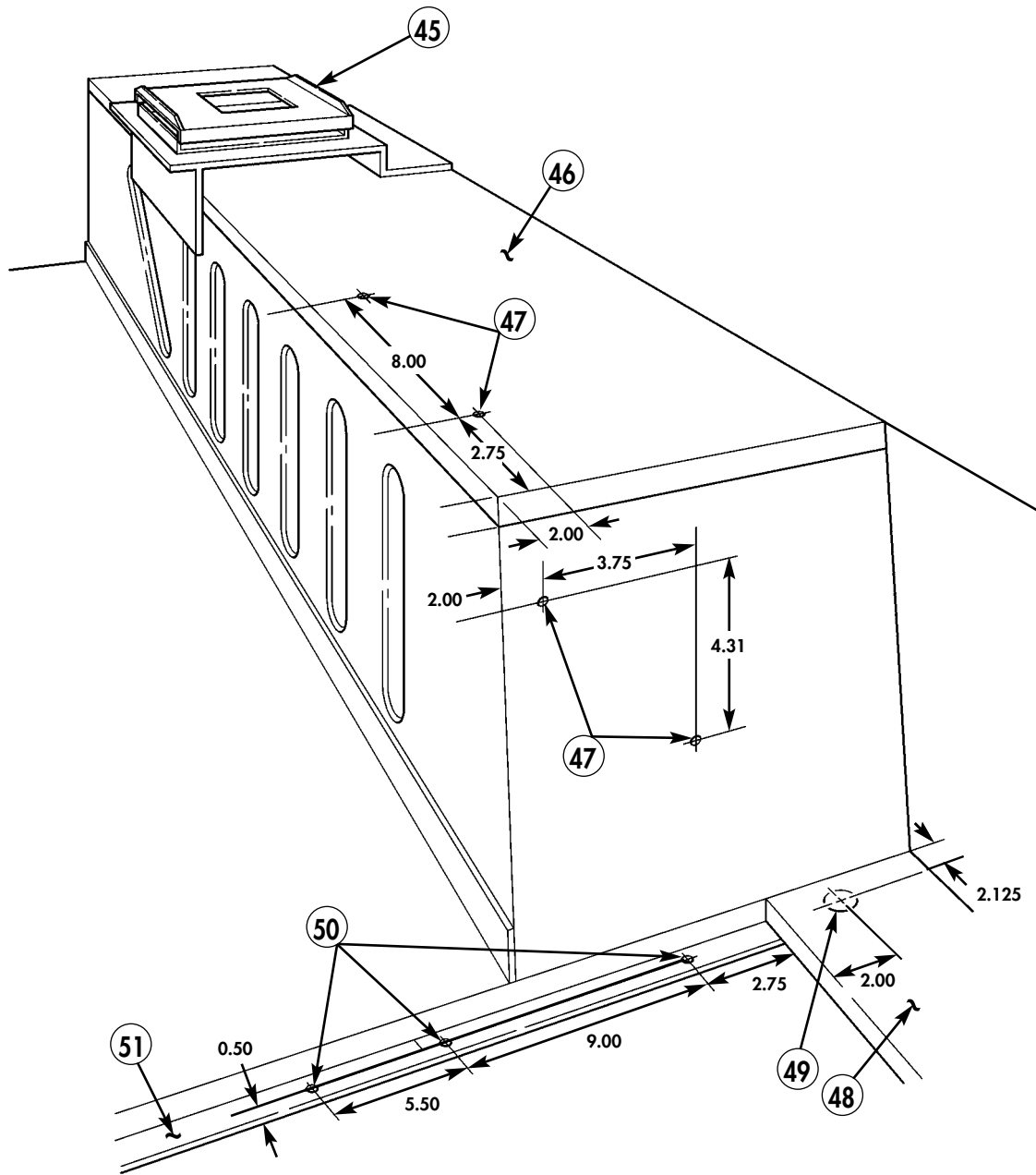
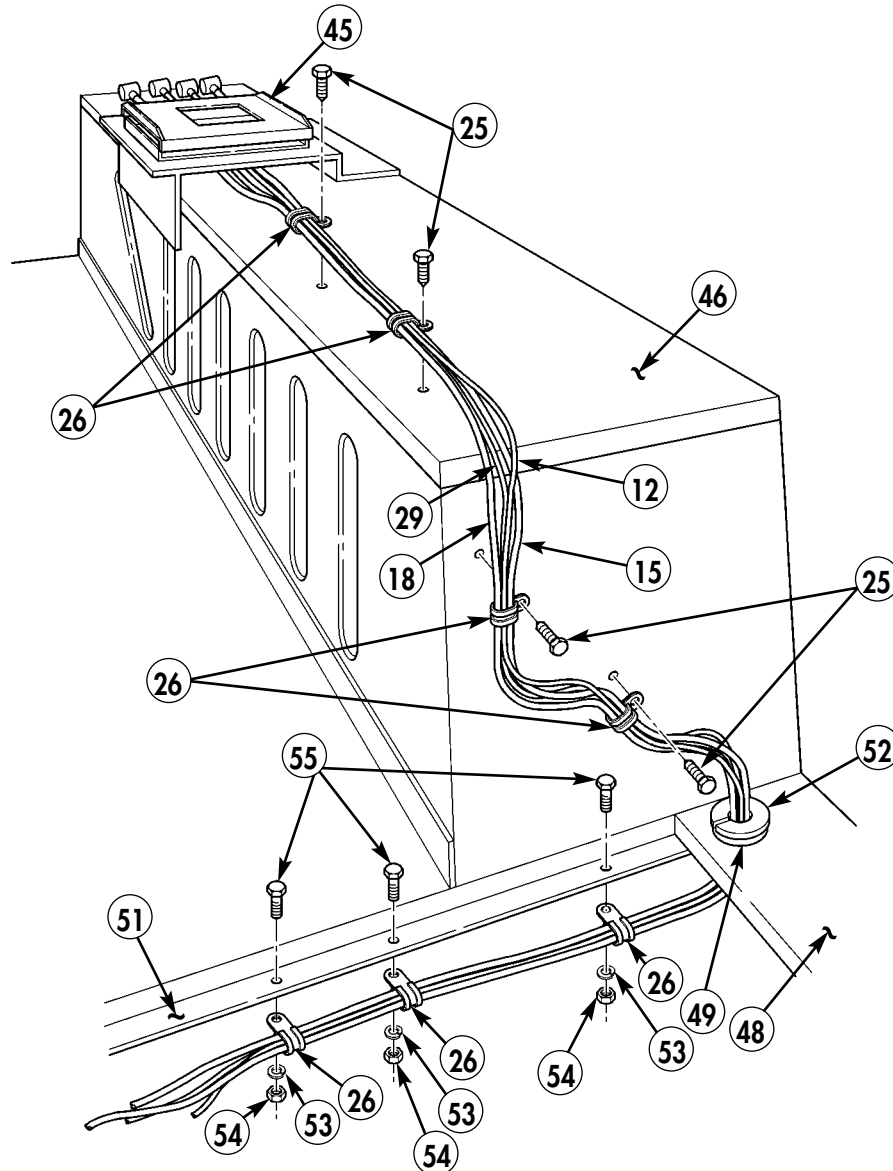

Figure 5-86.

- 21-24. Position grommet (52) in access hole (49).
- 21-25. Route all cables (12), (15), and (29) under fixed rear door (48) and along rear perimeter of left rear seat back support (51), and secure with three loop clamps (26), screws (55), lockwashers (53), and plain-assembled nuts (54).
- 21-26. Route all cables (12), (15), and (29) through access hole (49) and grommet (52).
- 21-27. Secure all cables (12), (15), and (29) to left rear wheelhouse (46) with four clamps (26) and self-tapping screws (25).
- 21-28. Take all slack out of all cables and store under EPLRS mount assembly (45).
- 21-29. Tighten all screws and nuts on all clamps.
- 21-30. Secure right-side tunnel insulation. (Refer to TM 9-2320-280-20.)



- 25. SELF-TAPPING SCREW - 9421073 - QTY. 4
- 26. LOOP CLAMP - MS21333-77 - QTY. 7
- 52. GROMMET - MS35489-24 - QTY. 1
- 53. LOCKWASHER - MS35338-43 - QTY. 3
- 54. NUT, PLAIN-ASSEMBLED - 9422771 - QTY. 3
- 55. SCREW - MS35206-265 - QTY. 3

Figure 5-87.

Section XXII. FRONT SINGARS CABLES INSTALLATION (TWO-MAN VEHICLES)

NOTE

Perform following procedures for two-man vehicle configuration only.

- 22-1. Locate, mark, and drill one 0.281-in. hole (9) in side of antenna base bracket (10).
- 22-2. Route SINGARS antenna cable (11) through hole (4) in overcab mount (2) and antenna base bracket (10) and connect antenna cable (11) to antenna (1).
- 22-3. Install grommet (5) in antenna base bracket (10) and overcab mount (2).
- 22-4. Secure antenna cable (11) to antenna base bracket (10) with loop clamp (6), capscrew (3), lockwasher (7), and nut (8).
- 22-5. Connect antenna ground strap (12) to antenna (1) with screw (14) and lockwasher (13).
- 22-6. Connect antenna ground strap (12) to antenna base bracket (10) with screw (15), two lockwashers (16), lockwasher (17), and nut (18).

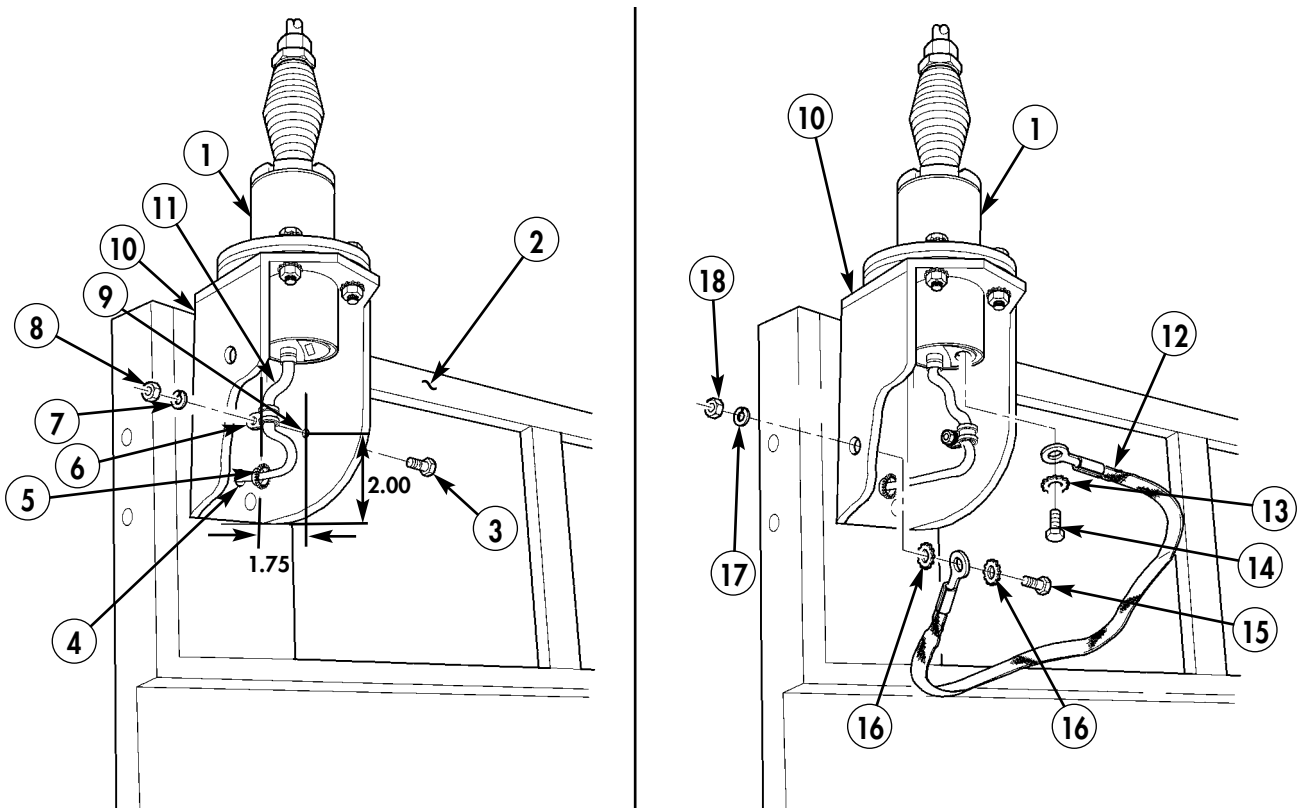

- 3. CAPSCREW - B1821BH025C075N - QTY. 1
- 5. GROMMET - MS21266-4N - QTY. A/R
- 6. CLAMP, LOOP - MS21333-98 - QTY. 1
- 7. LOCKWASHER - MS35338-44 - QTY. 1
- 8. NUT, HEXAGON - 9419143 - QTY. 1
- 11. CABLE, SINGARS ANTENNA - A3014031-8 - QTY. 1

Figure 5-88.

- 22-7. Route SINCGARS antenna cable (11) down B-pillar (19) to cab enclosure panel (23).
- 22-8. Locate, mark, and drill one 0.281-in. hole (27) in right overcab mount (2).
- 22-9. Secure right-side SINCGARS antenna cable (11) to overcab mount (2) with clamp (28), screw (29), and nut (26).

NOTE

Clamps will be large to accommodate speaker cables installed in Section XXIX.

- 22-10. Secure SINCGARS antenna cable to B-pillar (19) with three clamps (20) and existing screws (21).
- 22-11. Secure SINCGARS antenna cable (11) to cab enclosure panel (23) with three clamps (22) and existing screws (29).
- 22-12. Route SINCGARS antenna cable (11) under integrated rack (25), up through access hole, and to vicinity of SINCGARS mount.

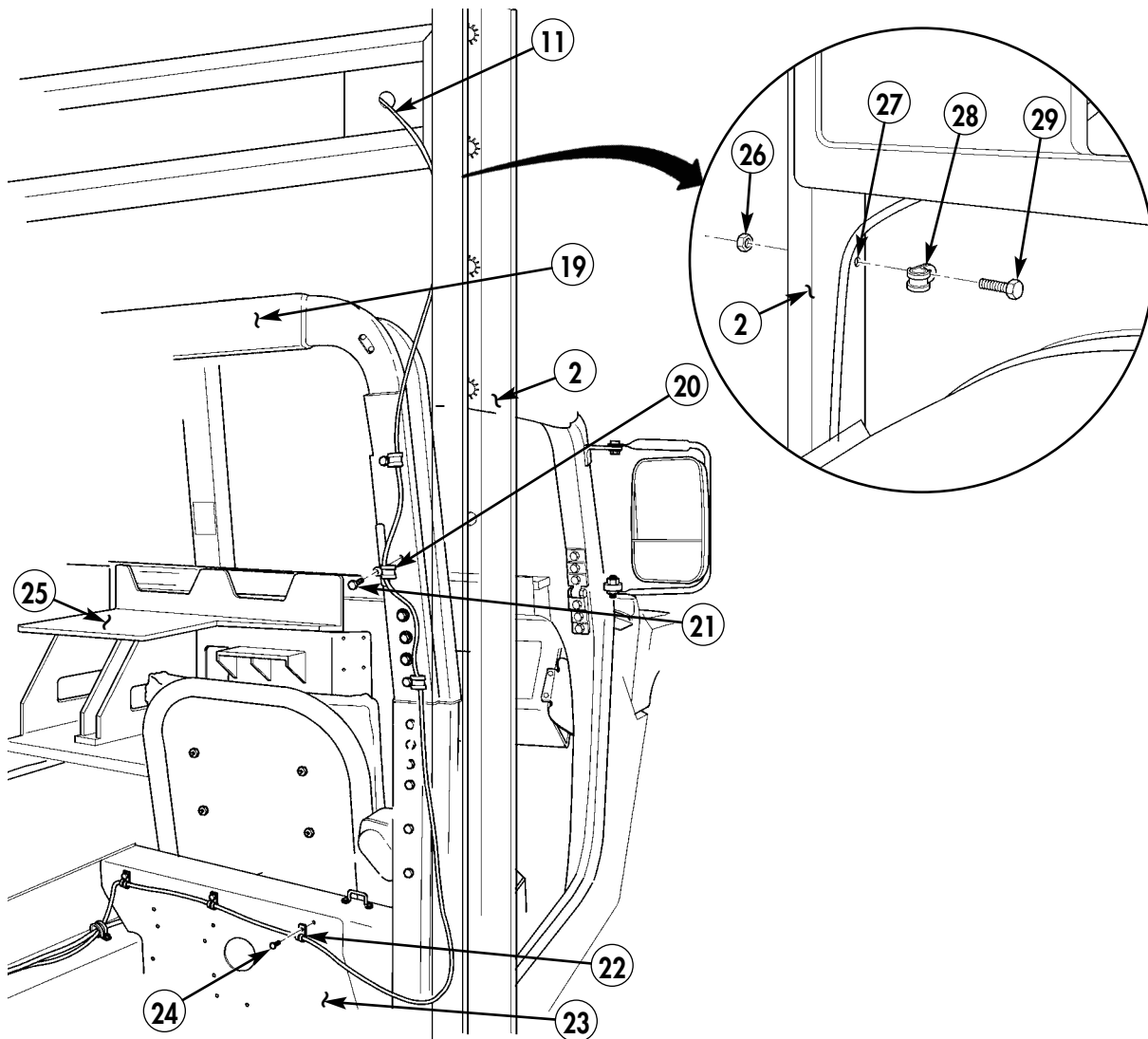

- 20. LOOP CLAMP – MS21333-112 – QTY. 3
- 22. LOOP CLAMP – MS21333-69 – QTY. 3
- 26. NUT – 9419143 – QTY. 1
- 28. LOOP CLAMP – MS21333-98 – QTY. 1
- 29. CAPSCREW – B1821BH025C075N – QTY. 1

Figure 5-89.

Section XXIII. EPLRS CABLES INSTALLATION (FOUR-MAN VEHICLES)

NOTE

- Loosen tunnel insulation before performing steps 23-1 and 23-2. (Refer to TM 9-2320-280-20.)
- SINCGARS model AN/VRC-92F shown.
- Perform following procedures for four-man vehicle configuration only.

23-1. Route INC-EPUU cable (1) from integrated rack (3), down through center access hole (2), and under left-side tunnel insulation (5) towards rear of vehicle.

23-2. Route power cable (4) from rear battery box forward and under integrated rack (3) and under left-side tunnel insulation (5) towards rear of vehicle.

23-3. Secure left-side tunnel insulation (5). (Refer to TM 9-2320-280-20.)

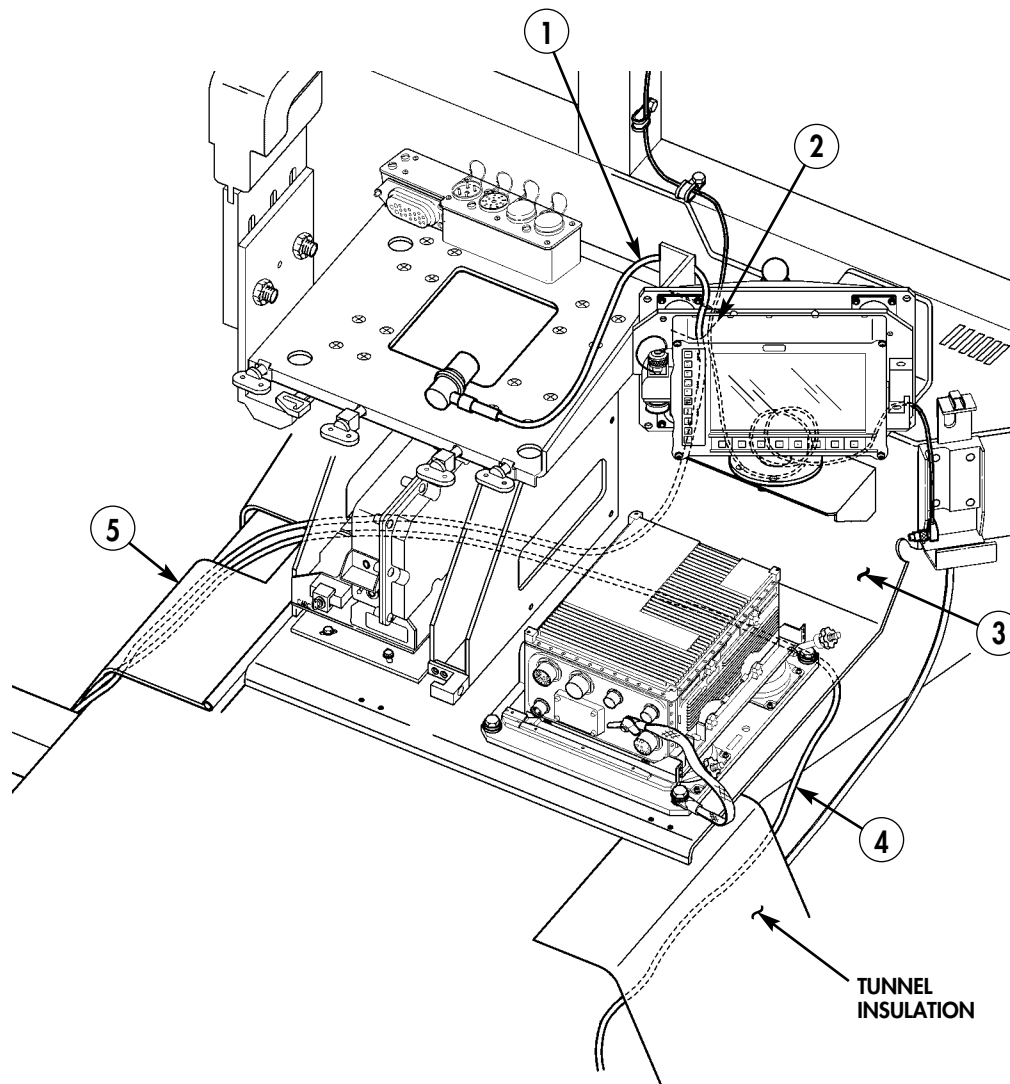

- 1. INC-EPUU CABLE – A3279383-3 – QTY. 1
- 4. EPLRS POWER CABLE – A3004939 – QTY. 1

Figure 5-90.

NOTE

Perform step 23-4 for vehicles with left rear cab enclosure panel only.

- 23-4.** Cut 2x2 in. section (13) from left rear cab enclosure panel (11). Install grommet (12). Reinstall cab enclosure panel (11). (Refer to TM 9-2320-280-20.)
- 23-5.** Locate, mark, and drill three 0.147-in. holes (8) along tunnel edge (9).
- 23-6.** Route INC-EPUU cable (1) and power cable (4) rearward under left-side B-beam (10) and along tunnel edge (9).
- 23-7.** Route INC-EPUU cable (1) and power cable (4) rearward along tunnel edge (9) and secure with three clamps (7) and self-tapping screws (6).

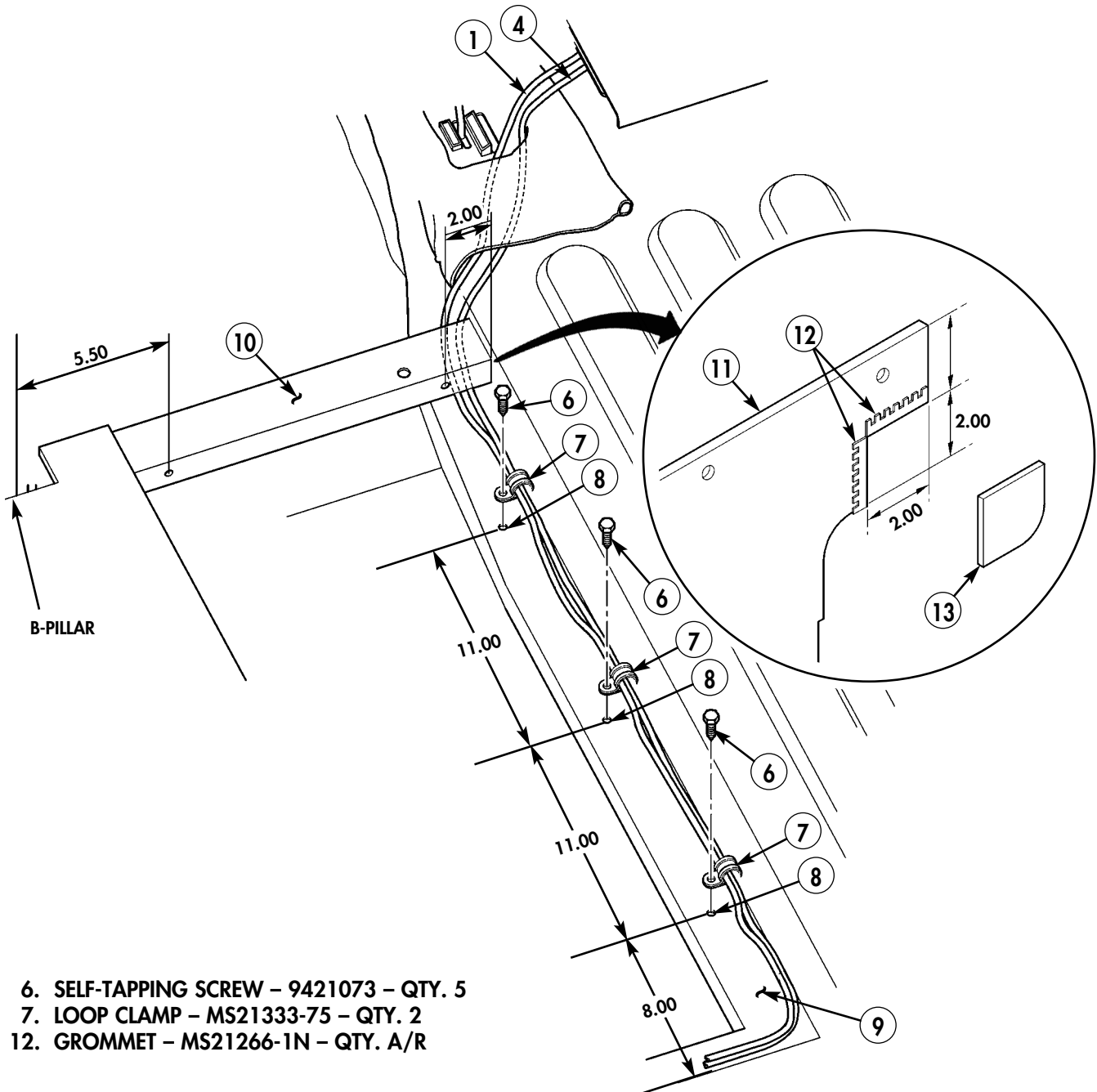

6. SELF-TAPPING SCREW - 9421073 - QTY. 5
 7. LOOP CLAMP - MS21333-75 - QTY. 2
 12. GROMMET - MS21266-1N - QTY. A/R

Figure 5-91.

TB 9-2320-280-35-13

- 23-8.** Locate, mark, and drill one 0.225-in. hole (22) in inboard corner on rear inside lip of left rear seat back support (19).
- 23-9.** Locate, mark, and drill two 0.147-in. holes (24) in front face of left rear wheelhouse (17).
- 23-10.** Route cables (16), (1), and (4) along rear perimeter of left rear seat back support (19), up front face of left rear wheelhouse (17), and under antenna base (30).
- 23-11.** Secure cables (16), (1), and (4) to left rear wheelhouse (17) with screw (23), lockwasher (21), nut (20), two self-tapping screws (18), two existing screws (14), and five loop clamps (15).
- 23-12.** Route cables (1) and (4) to EPLRS mount (32)
- 23-13.** Secure antenna cable (16) to antenna base (30) with existing loop clamps (29), screws (25), washers (26), lockwashers (27), and nuts (28).
- 23-14.** Connect antenna cable (16) to antenna (31).
- 23-15.** Take all slack out of cable and store under EPLRS mount assembly.
- 23-16.** Tighten all screws and nuts on all clamps.
- 23-17.** Secure right-side tunnel insulation. (Refer to TM 9-2320-280-20.)

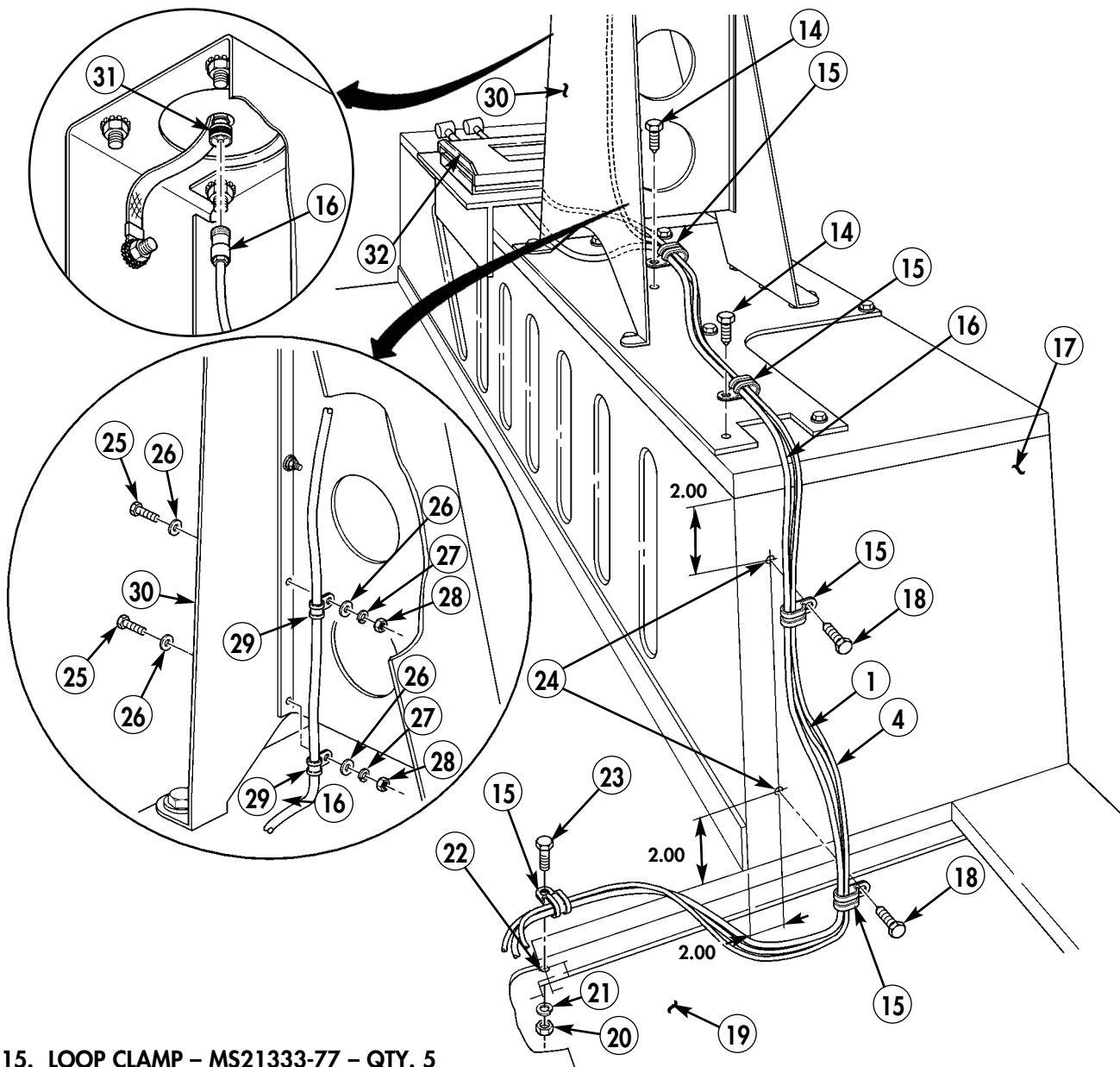

- 15. LOOP CLAMP - MS21333-77 - QTY. 5
- 16. ANTENNA CABLE - SM-C-911480 - QTY. 1
- 18. SELF-TAPPING SCREW - 9421073 - QTY. 2
- 20. NUT, PLAIN-ASSEMBLED - 9422771 - QTY. 1
- 21. LOCKWASHER - MS35338-43 - QTY. 1
- 23. SCREW - MS35206-265 - QTY. 1
- 29. LOOP CLAMP - MS21333-102 - QTY. 2

Figure 5-92.

Section XXIV. RIGHT-SIDE SINGARS PEDESTAL ANTENNA INSTALLATION (FOUR-MAN VEHICLES)

NOTE

Perform following procedures for four-man vehicle configuration only.

- 24-1.** Assemble antenna mounting bracket (3) and antenna base reinforcement bracket (4) with eight screws (1), sixteen lockwashers (2), and eight nuts (5). Do not tighten nuts (5) at this time.

NOTE

Remove paint or tape from mounting holes.

- 24-2.** Remove paint from vicinity of all mounting holes on both antenna plates, antenna mount assembly, and ground strap. Apply anti-seize compound as required.

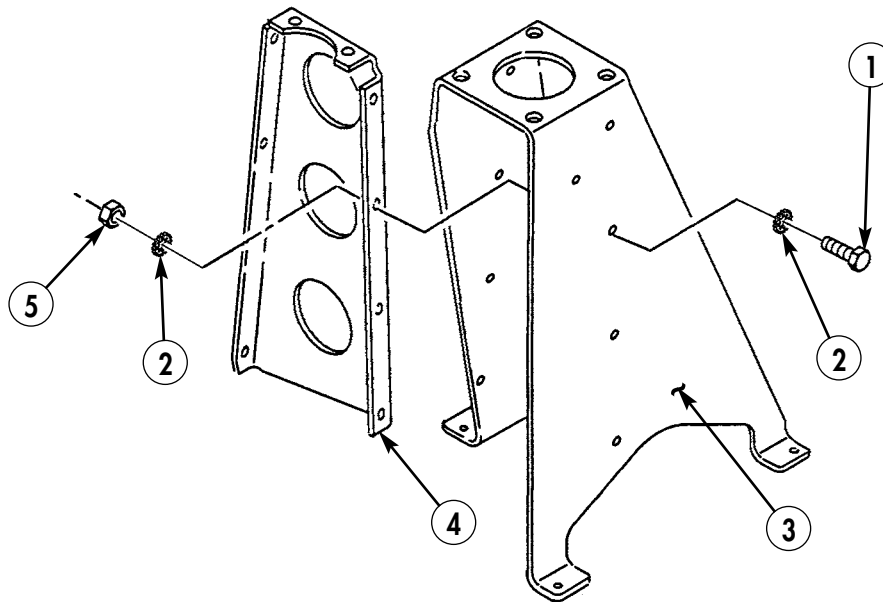

1. SCREW - B1821BH025C100N - QTY. 8
2. LOCKWASHER - MS35338-44 - QTY. 16
3. ANTENNA MOUNTING BRACKET - A3018371-2 - QTY. 1
4. ANTENNA BASE REINFORCEMENT BRACKET - A3018372-2 - QTY. 1
5. NUT - MS51967-2 - QTY. 8

Figure 5-93.

NOTE

- Remove right rear side rail, if necessary.
(Refer to TM 9-2320-280-20.)
- Rear edge of upper mounting plate should be approximately 1.187 in. from front edge of EPLRS mounting plate.

- 24-3.** Locate screw (10) on right rear wheelhouse (7) and drill out rivet (9) from right rear wheelwell (7). Enlarge hole to 0.281 in.
- 24-4.** Position support plate underneath wheelhouse (7) and drill two 0.281-in. diameter holes.
- 24-5.** Using upper antenna plate (6) as template, locate, mark, and drill thirteen 0.281-in. holes (8) and three 0.408-in. holes (11) in left rear wheelhouse (7).

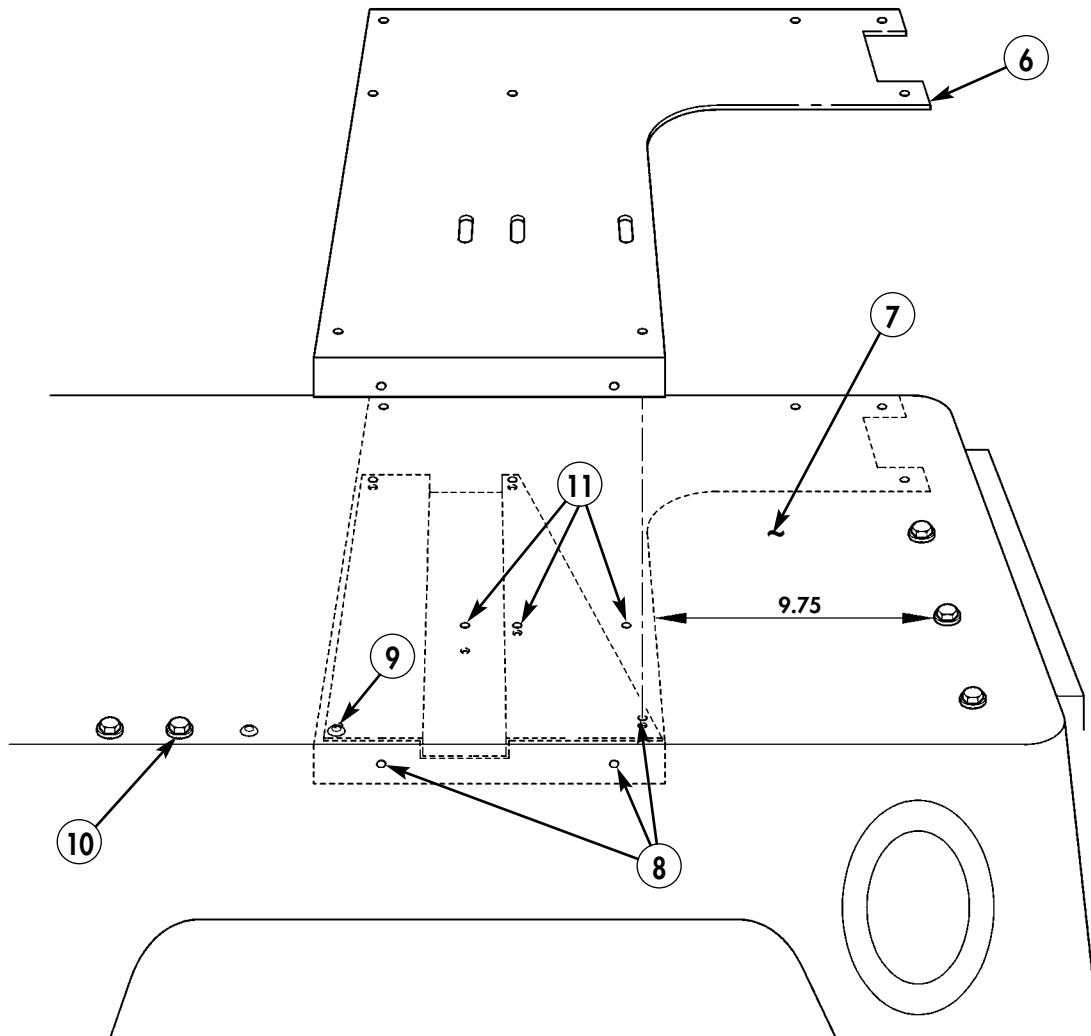

6. ANTENNA PLATE – A3104004-1 – QTY. 1

Figure 5-94.

NOTE

Enlarge hole on antenna mount assembly to accomodate 7/16-in. bolts.

- 24-6.** Install antenna mount assembly (23), upper antenna plate (6), and lower antenna plate (15) on left rear wheelhouse (7) with eleven capscrews (21), twenty-two washers (20), eleven lockwashers (19), and eleven nuts (18).
- 24-7.** Install antenna mount assembly (23), upper antenna plate (6), and lower antenna plate (15) on left rear wheelhouse (7) with two capscrews (12), four washers (13), two lockwashers (16), and two nuts (17).
- 24-8.** Secure antenna mount assembly (23), upper antenna plate (6), and lower antenna plate (15) to left rear wheelhouse (7) with two capscrews (22), four washers (20), two lockwashers (19), and two nuts (18).
- 24-9.** Secure antenna mount assembly (23), upper antenna plate (6), and lower antenna plate (15) to left rear wheelhouse (7) with one capscrew (14), two washers (13), one lockwasher (16), and one nut (17).

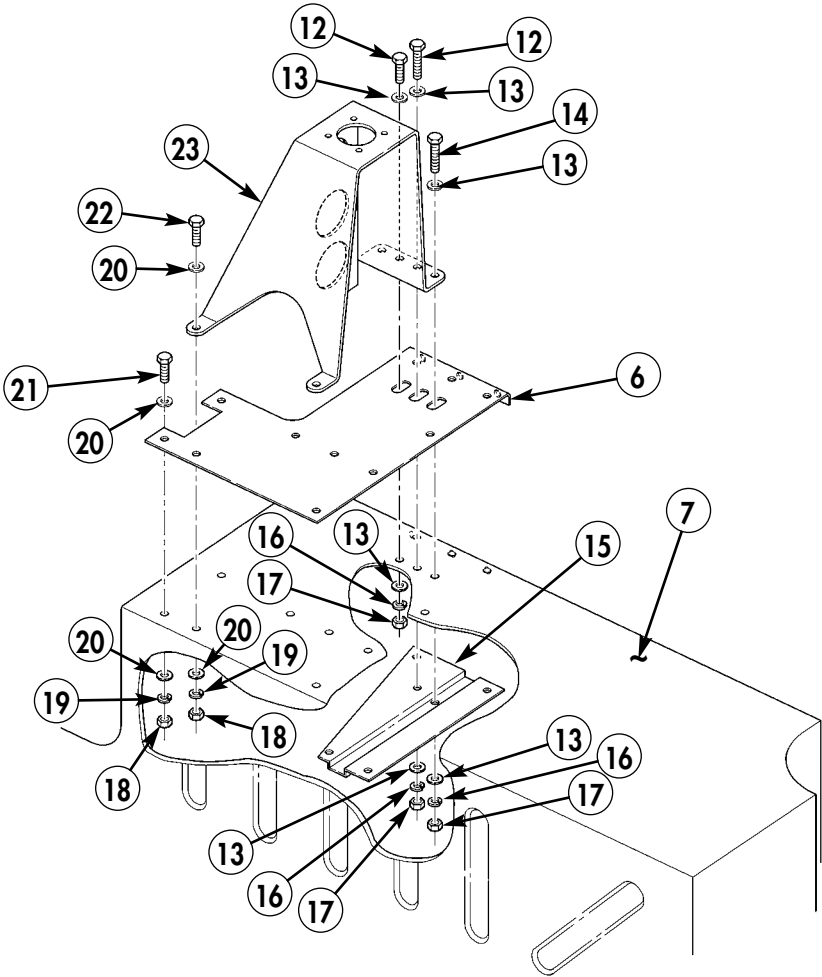

- 12. CAPSCREW – B1821BH044C125N – QTY. 2
- 13. WASHER – 2436163 – QTY. 6
- 14. CAPSCREW – B1821BH044C150N – QTY. 1
- 15. ANTENNA PLATE – A3157619 – QTY. 1
- 16. LOCKWASHER – 120382 – QTY. 3
- 17. NUT – 13218E0320-293 – QTY. 3

- 18. NUT – 9419143 – QTY. 13
- 19. LOCKWASHER – MS35338-44 – QTY. 13
- 20. WASHER – 2436161 – QTY. 26
- 21. CAPSCREW – B1821BH025C100N – QTY. 11
- 22. CAPSCREW – B1821BH025C150N – QTY. 2

Figure 5-95.

NOTE

Perform step 24-10 only if not installing cargo soft-top enclosure; otherwise, start with step 24-11.

- 24-10.** Install antenna (25) on antenna mount assembly (23) with four capscrews (24), gasket (26), eight lockwashers (31), and four nuts (30).

NOTE

Perform steps 24-11 through 24-12 only when installing cargo soft-top enclosure.

- 24-11.** Install cargo soft-top enclosure (32). (Refer to TM 9-2320-280-10.)

NOTE

Ensure all slack has been taken out of cargo soft-top enclosure, and that cargo soft-top enclosure has been properly installed.

- 24-12.** Using antenna (25) as template, locate, mark, and drill four 0.375-in. holes (33) and cut "X" (34) in cargo soft-top enclosure (32).
- 24-13.** Install antenna (25) on antenna mount assembly (23) and cargo soft-top enclosure (32) with gasket (26), eight lockwashers (31), and four nuts (30), ensuring that ground strap (29) is inserted through cut hole (34).
- 24-14.** Install ground strap (29) on antenna mount assembly (23) with screw (28), three lockwashers (27), and nut (18).
- 24-15.** Tighten all nuts (18) and (30).

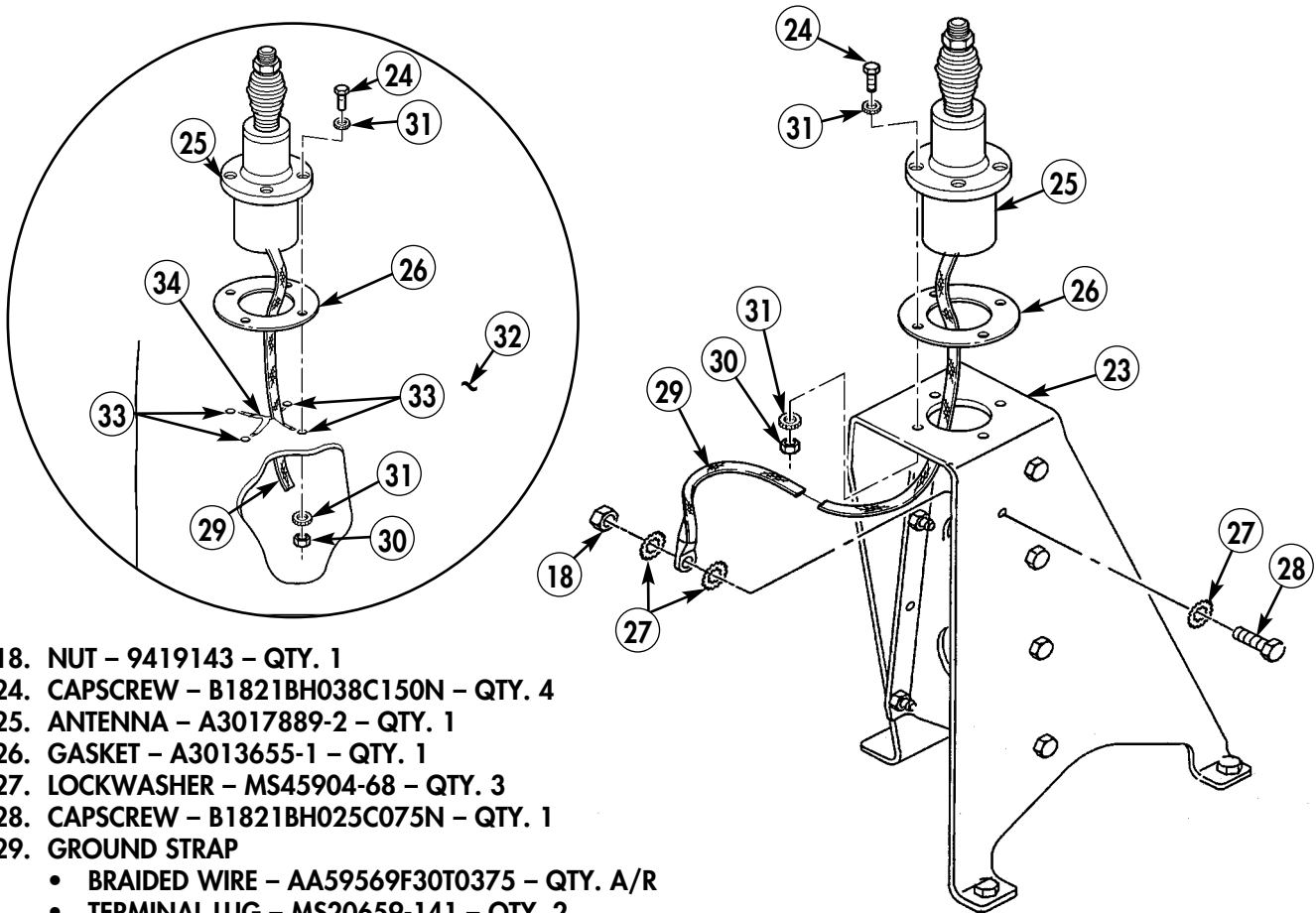

- 18. NUT - 9419143 - QTY. 1
- 24. CAPSCREW - B1821BH038C150N - QTY. 4
- 25. ANTENNA - A3017889-2 - QTY. 1
- 26. GASKET - A3013655-1 - QTY. 1
- 27. LOCKWASHER - MS45904-68 - QTY. 3
- 28. CAPSCREW - B1821BH025C075N - QTY. 1
- 29. GROUND STRAP
 - BRAIDED WIRE - AA59569F30T0375 - QTY. A/R
 - TERMINAL LUG - MS20659-141 - QTY. 2
- 30. NUT - 13218E0320-293 - QTY. 4
- 31. LOCKWASHER - MS45904-76 - QTY. 8

Figure 5-96.

- 24-16.** Attach upper antenna element (35) to lower antenna element (37).
- 24-17.** Attach antenna assembly to antenna base (25).
- 24-18.** Attach fiber rope assembly (36) to upper antenna element (35).
- 24-19.** Secure lower antenna element (37) to antenna base (25) with lockwire (38).

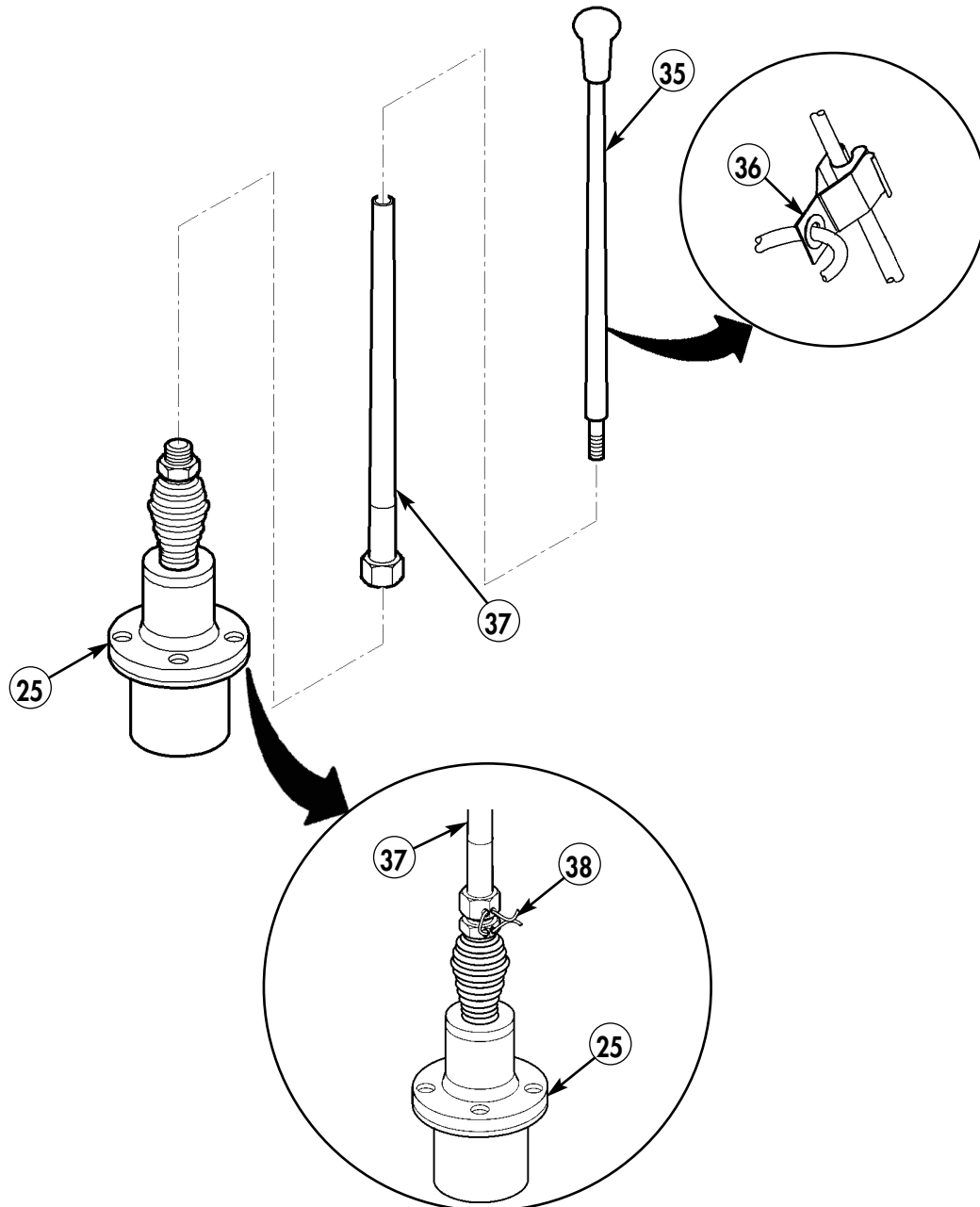

- 35.** UPPER ANTENNA ELEMENT – A3017901-2 – QTY. 1
- 36.** FIBER ROPE ASSEMBLY – A3167672-1 – QTY. 1
- 37.** LOWER ANTENNA ELEMENT – A3018230-1 – QTY. 1
- 38.** LOCKWIRE – MS20995C32 – QTY. A/R

Figure 5-97.

Section XXV. LEFT-SIDE EPLRS PEDESTAL ANTENNA INSTALLATION (FOUR-MAN VEHICLES)

NOTE

Perform following procedures for four-man vehicle configuration only.

- 25-1. Assemble antenna mounting bracket (3) and antenna base reinforcement bracket (4) with eight capscrews (1), sixteen lockwashers (2), and eight nuts (5). Do not tighten nuts (5) at this time.
- 25-2. Remove paint from vicinity of all mounting holes on both antenna plates, antenna mount assembly, and ground strap. Apply anti-seize compound as required.

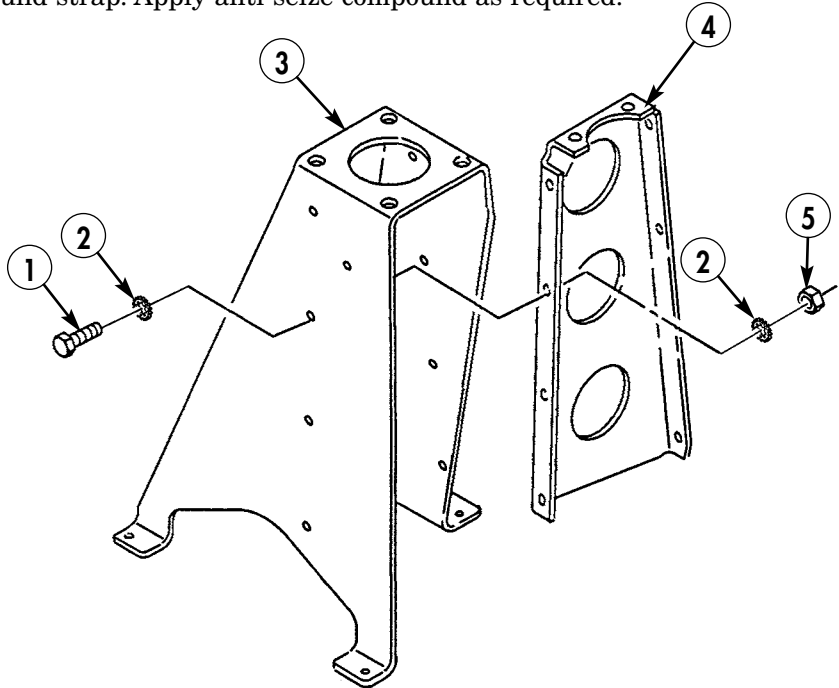

- 1. CAPSCREW – B1821BH025C100N – QTY. 8
- 2. LOCKWASHER – MS35338-44 – QTY. 16
- 3. ANTENNA MOUNTING BRACKET – A3018371-1 – QTY. 1
- 4. ANTENNA BASE REINFORCEMENT BRACKET – A3018372-1 – QTY. 1
- 5. NUT – MS51967-2 – QTY. 8

Figure 5-98.

NOTE

- Remove left rear side rail, if necessary.
(Refer to TM 9-2320-280-20.)
- Rear edge of upper mounting plate should be approximately 1.187 in. from front edge of EPLRS mounting plate.

- 25-3.** Locate screw (7) on left rear wheelhouse (11), and drill out rivet (8) from left rear wheelhouse (11). Enlarge hole to 0.281 in.
- 25-4.** Position support plate underneath wheelhouse (11) and drill two 0.281-in. diameter holes.
- 25-5.** Using upper antenna plate (6) as template, locate, mark, and drill nine 0.281-in. holes (9) and three 0.408-in. holes (10) in left rear wheelhouse (11).

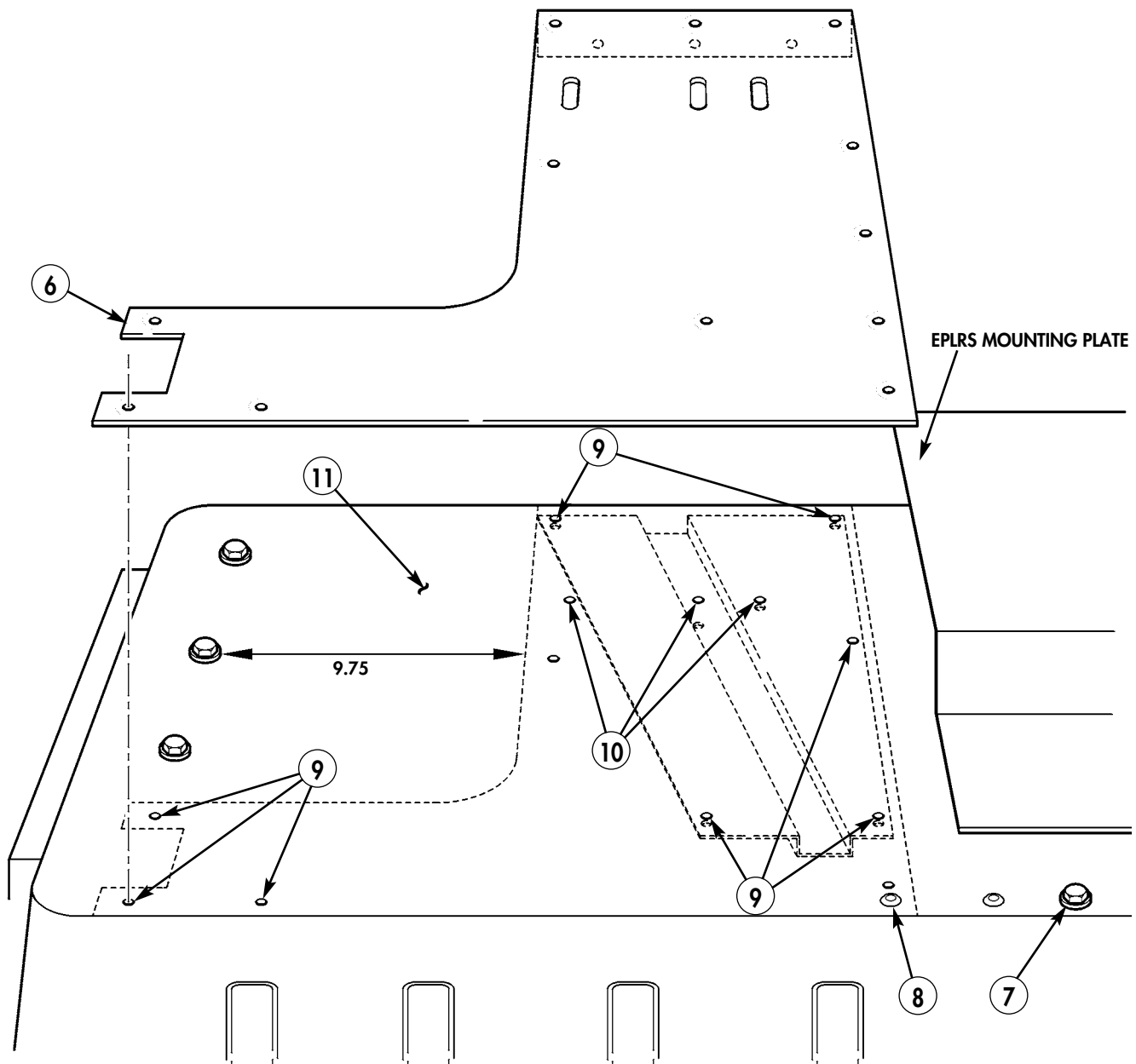

6. ANTENNA PLATE - A3104004-1 - QTY. 1

Figure 5-99.

NOTE

Enlarge hole on antenna mount assembly to accommodate 7/16-in. bolts.

- 25-6. Install antenna mount assembly (14), upper antenna plate (6), and lower antenna plate (20) on left rear wheelhouse (11) with eleven capscrews (17), twenty-two washers (16), eleven lockwashers (18), and eleven nuts (19).
- 25-7. Secure antenna mount assembly (14), upper antenna plate (6), and lower antenna plate (20) to left rear wheelhouse (11) with two capscrews (12), four washers (13), two lockwashers (21), and two nuts (22).
- 25-8. Secure antenna mount assembly (14), upper antenna plate (6), and lower antenna plate (20) to left rear wheelhouse (11) with two capscrews (15), four washers (16), two lockwashers (18), and two nuts (19).
- 25-9. Secure antenna mount assembly (14), upper antenna plate (6), and lower antenna plate (20) to left rear wheelhouse (11) with one capscrew (23), two washers (13), one lockwasher (21), and one nut (22).

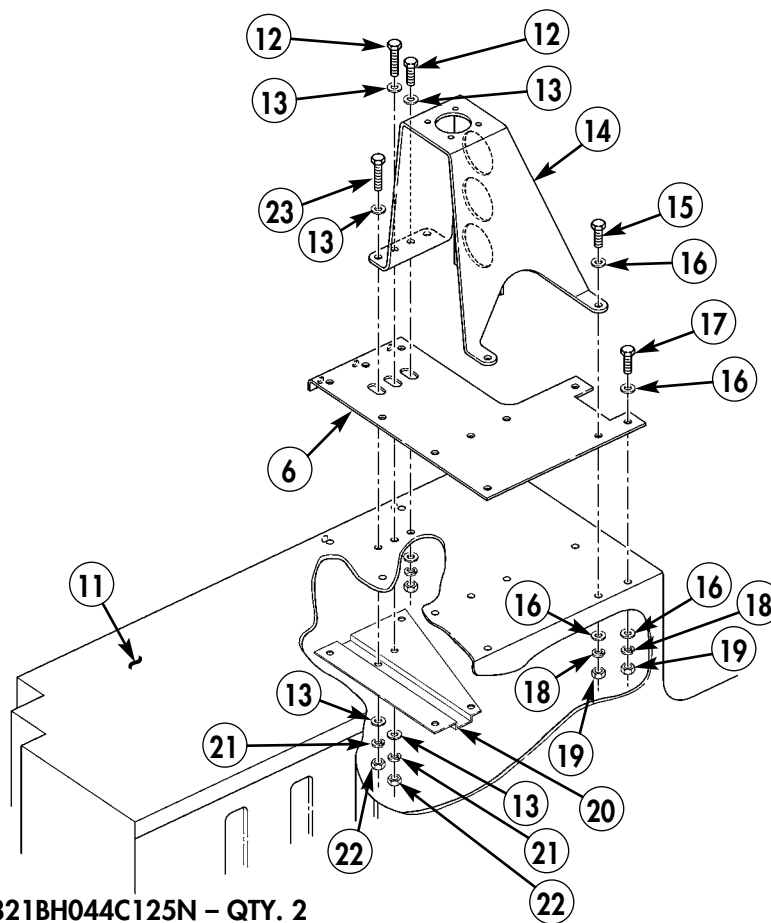

- 12. CAPSCREW - B1821BH044C125N - QTY. 2
- 13. WASHER - 2436163 - QTY. 6
- 15. CAPSCREW - B1821BH025C150N - QTY. 2
- 16. WASHER - 2436161 - QTY. 26
- 17. CAPSCREW - B1821BH025C100N - QTY. 11
- 18. LOCKWASHER - MS35338-44 - QTY. 13
- 19. NUT - 9419143 - QTY. 13
- 20. ANTENNA PLATE - A3157619 - QTY. 1
- 21. LOCKWASHER - 120382 - QTY. 3
- 22. NUT - 13218E0320-293 - QTY. 3
- 23. CAPSCREW - B1821BH044C150N - QTY. 1

Figure 5-100.

NOTE

Perform step 25-10 only if not installing cargo soft-top enclosure; otherwise, start with step 25-11.

- 25-10.** Install antenna (31) on antenna mount assembly (14) with four capscrews (24), gasket (30), eight lockwashers (25), and four nuts (26).

NOTE

Perform steps 25-11 through 25-12 only when installing cargo soft-top enclosure.

- 25-11.** Install cargo soft-top enclosure (32). (Refer to TM 9-2320-280-10.)

NOTE

Ensure all slack has been taken out of cargo soft-top enclosure, and that cargo soft-top enclosure has been properly installed.

- 25-12.** Using antenna (31) as template, locate, mark, and drill four 0.375-in. holes (33) and cut "X" (34) in cargo soft-top enclosure (32).
- 25-13.** Install antenna (31) on antenna mount assembly (14) and cargo soft-top enclosure (32) with four capscrews (24), gasket (30), eight lockwashers (25), and four nuts (26), ensuring that ground strap (27) is inserted through cut hole (34).
- 25-14.** Install ground strap (27) on antenna mount assembly (14) with screw (29), three lockwashers (28), and nut (19).
- 25-15.** Tighten all nuts (19) and (26).

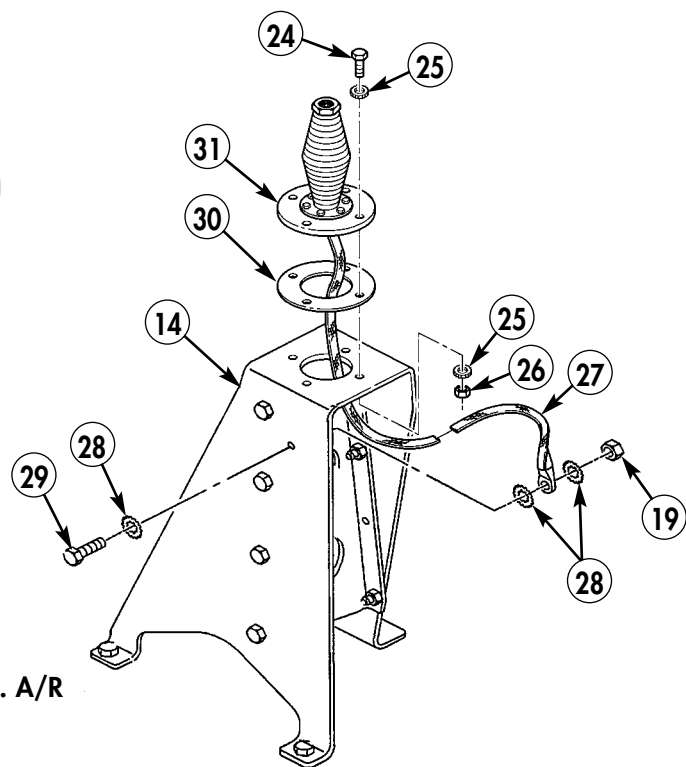
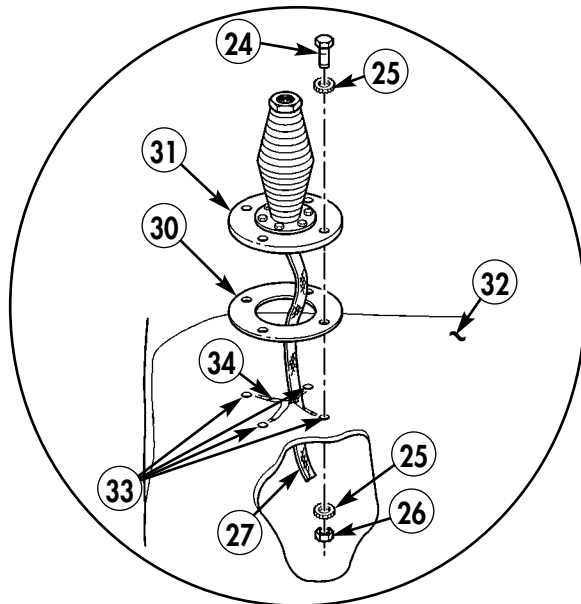

19. NUT - 9419143 - QTY. 1
 24. CAPSCREW - B1821BH038C150N - QTY. 4
 25. LOCKWASHER - MS45904-76 - QTY. 8
 26. NUT - 13218E0320-293 - QTY. 4
 27. GROUND STRAP
 • BRAIDED WIRE - AA59569F30T0375 - QTY. A/R
 • TERMINAL LUG - MS20659-141 - QTY. 2
 28. LOCKWASHER - MS45904-68 - QTY. 3
 29. CAPSCREW - B1821BH025C075N - QTY. 1
 30. GASKET - A3013655-1 - QTY. 1
 31. ANTENNA - A3005031 - QTY. 1

Figure 5-101.

Section XXVI. SINGARS ANTENNA CABLES INSTALLATION (FOUR-MAN VEHICLES)

NOTE

Perform following procedures for four-man vehicle configuration only.

- 26-1. Locate, mark, and drill one 0.225-in. hole (8) in inboard corner on rear inside lip of left rear seat back support (6).
- 26-2. Locate, mark, and drill two 0.147-in. holes (5) in front face of left rear wheelhouse (12).
- 26-3. Route EPLRS antenna cable (4) along rear perimeter of left rear seat back support (6), up front face of left rear wheelhouse (12), and up antenna base (1).

NOTE

Clamps are large to accommodate black charger cable from power entry box in step 26-4.

- 26-4. Secure EPLRS antenna cable (4) to seat back support (6) with screw (7), lockwasher (9), nut (10), two self-tapping screws (11), two existing screws (2), and five loop clamps (3).
- 26-5. Secure antenna cable (4) to antenna base (1) with clamps (14), existing screws (16), washers (15), lockwashers (17), and nuts (18).
- 26-6. Connect antenna cable (5) to antenna (19). Route antenna cable (4) through multi-net rack (13) to vicinity of EPLRS mount.
- 26-7. Tighten all screws and nuts on all clamps.
- 26-8. Secure right-side tunnel insulation. (Refer to TM 9-2320-280-20.)

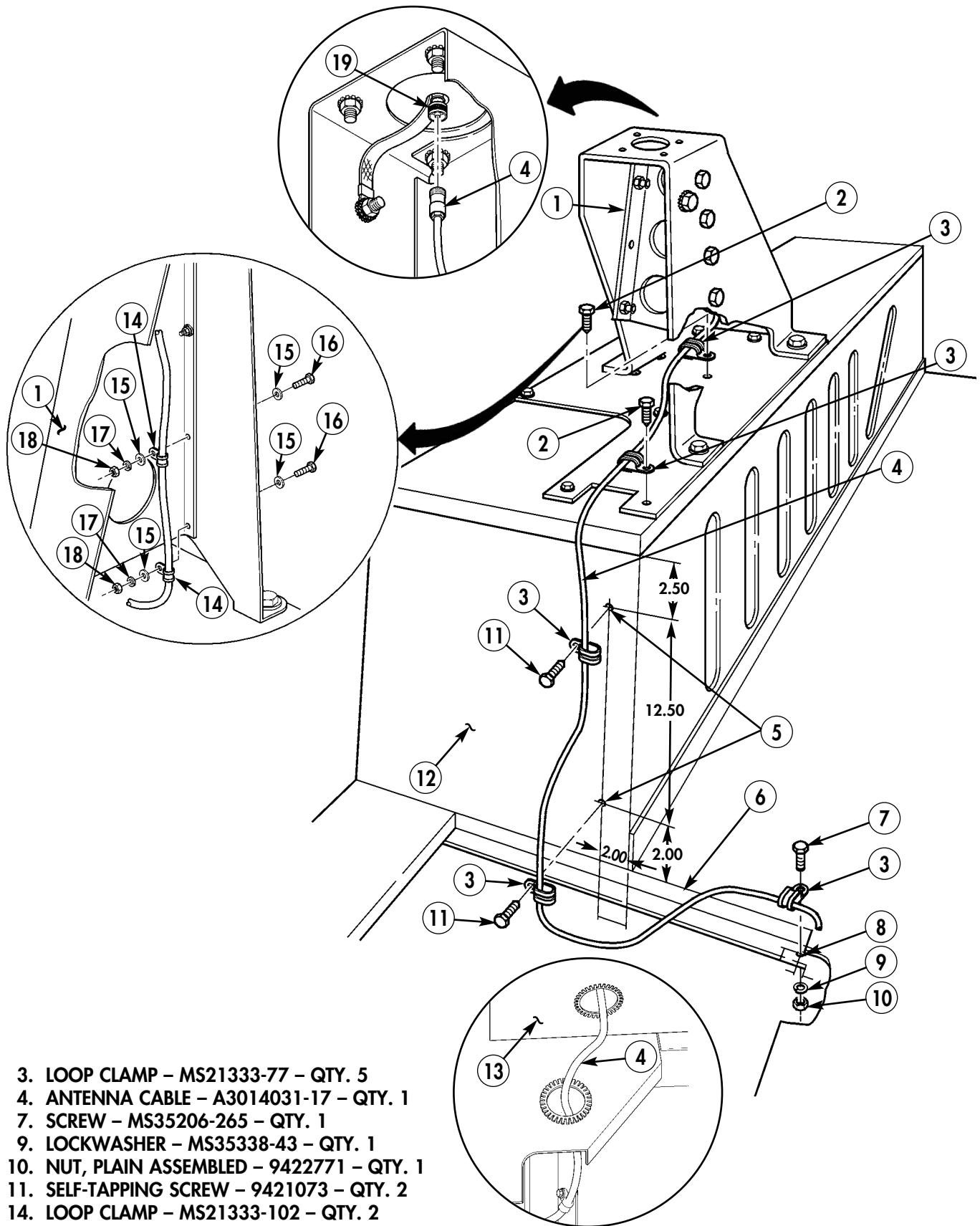
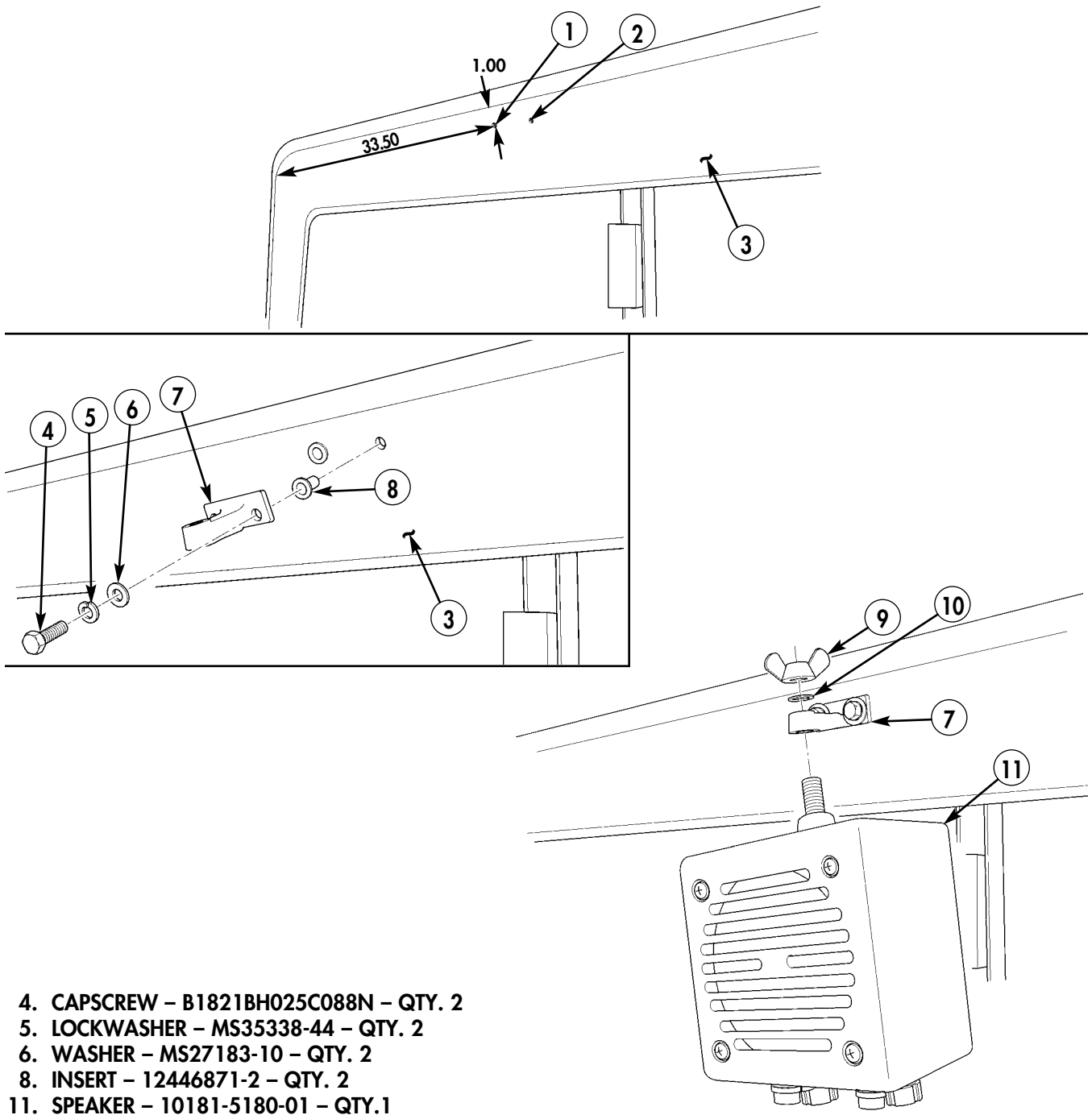

Figure 5-102.

Section XXVII. LOUDSPEAKER MOUNT INSTALLATION

- 27-1. Locate, mark, and drill one 0.391-in. diameter hole (1) in B-beam (3).
- 27-2. Using speaker mounting bracket (7) as template, locate, mark, and drill second 0.391-in. diameter hole (2) in B-beam.
- 27-3. Install two inserts (8) in holes (1) and (2) in B-beam (3).
- 27-4. Install loudspeaker mounting bracket (7) on B-beam (3) with two capscrews (4), lockwashers (5), and washers (6).
- 27-5. Install loudspeaker (11) on loudspeaker bracket (7) with existing lockwasher (10) and wing nut (9).



- 4. CAPSCREW – B1821BH025C088N – QTY. 2
- 5. LOCKWASHER – MS35338-44 – QTY. 2
- 6. WASHER – MS27183-10 – QTY. 2
- 8. INSERT – 12446871-2 – QTY. 2
- 11. SPEAKER – 10181-5180-01 – QTY.1

Figure 5-103.

Section XXVIII. KEY DISPLAY UNIT (KDU) MOUNT INSTALLATION

NOTE

Use triangular pattern to install ramball mount.

- 28-1.** Using mini-ramball mount base (3) as template, locate, mark, and drill three 0.203-in. diameter holes (4) in dash (6).
- 28-2.** Attach mini-ramball mount base (3) to dash (6) with three existing screws (1), six washers (2), and three locknuts (5).

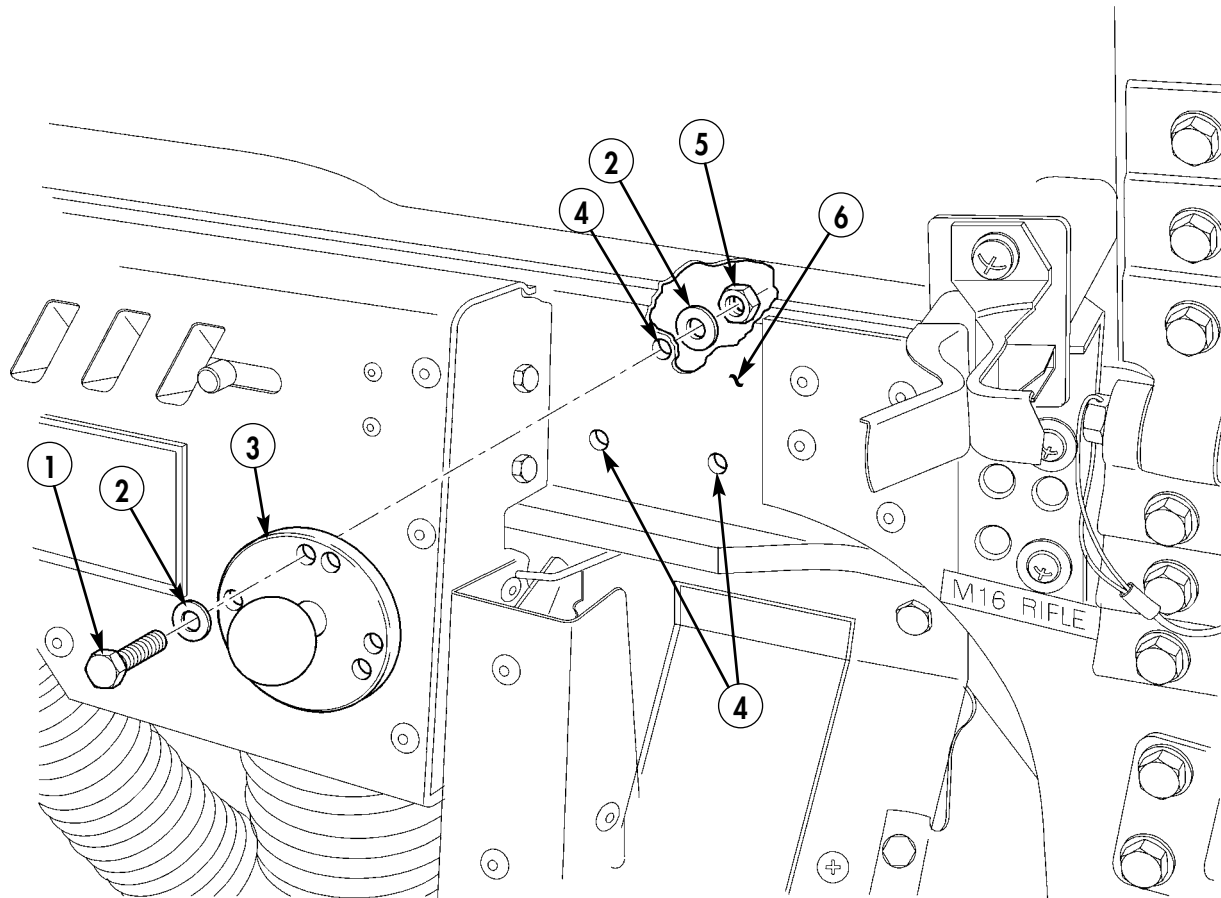

3. MINI-RAMBALL MOUNT - P/O 11071-0900-04 - QTY. 1

Figure 5-104.

28-3. Attach mini-ramball arm (7) and KDU mounting plate (8) to mini-ramball mount base (3) and secure with attached wingnut.

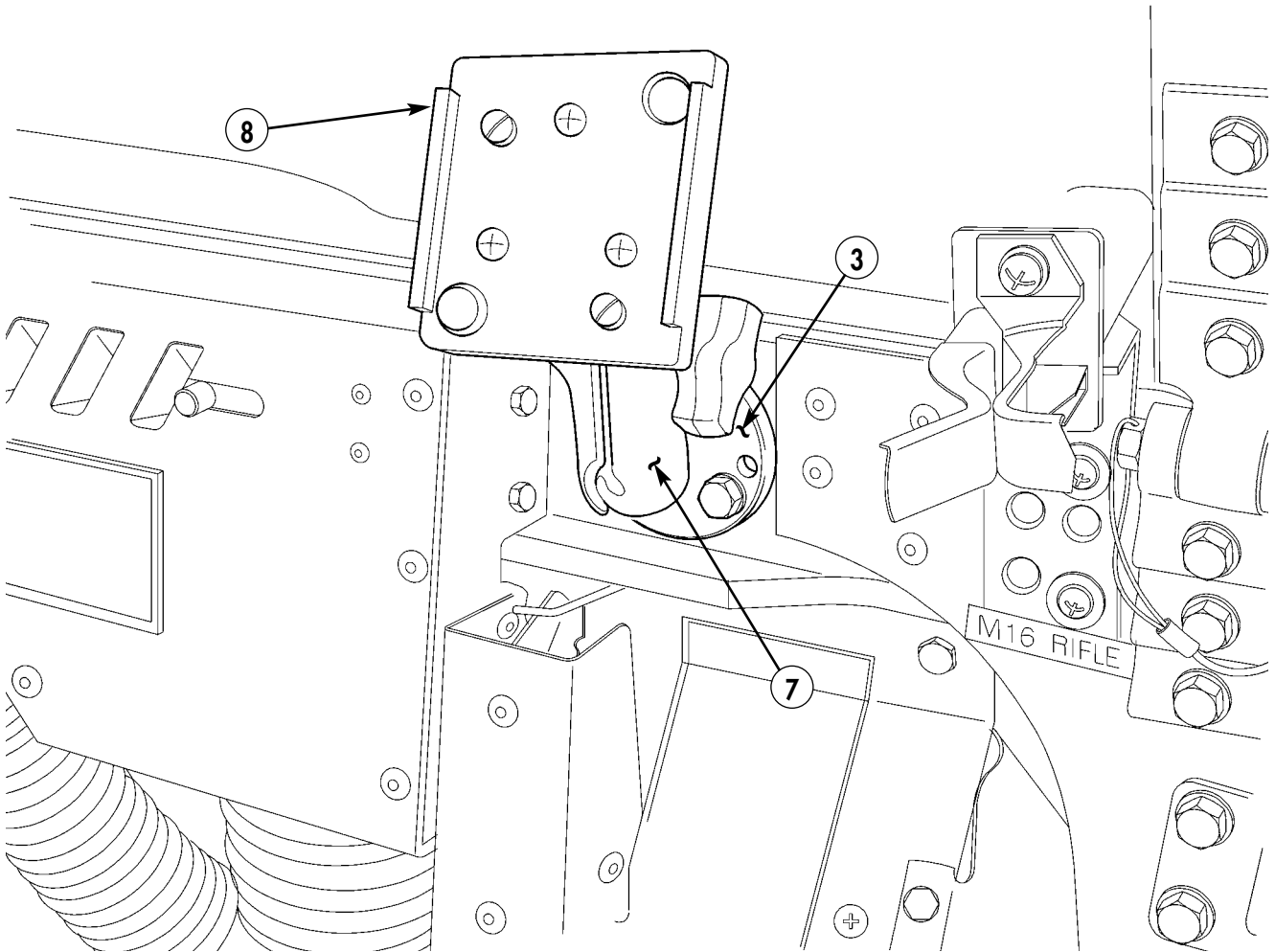

8. KDU MOUNTING PLATE - 11071-0900-04 - QTY. 1

Figure 5-105.

Section XXIX. HF 20 WATT RADIO CABLES INSTALLATION

- 29-1.** Route speaker cables (3) and (6) from speaker (4) along B-pillar (5) and secure with three loop clamps (2) and self-tapping screws (1).

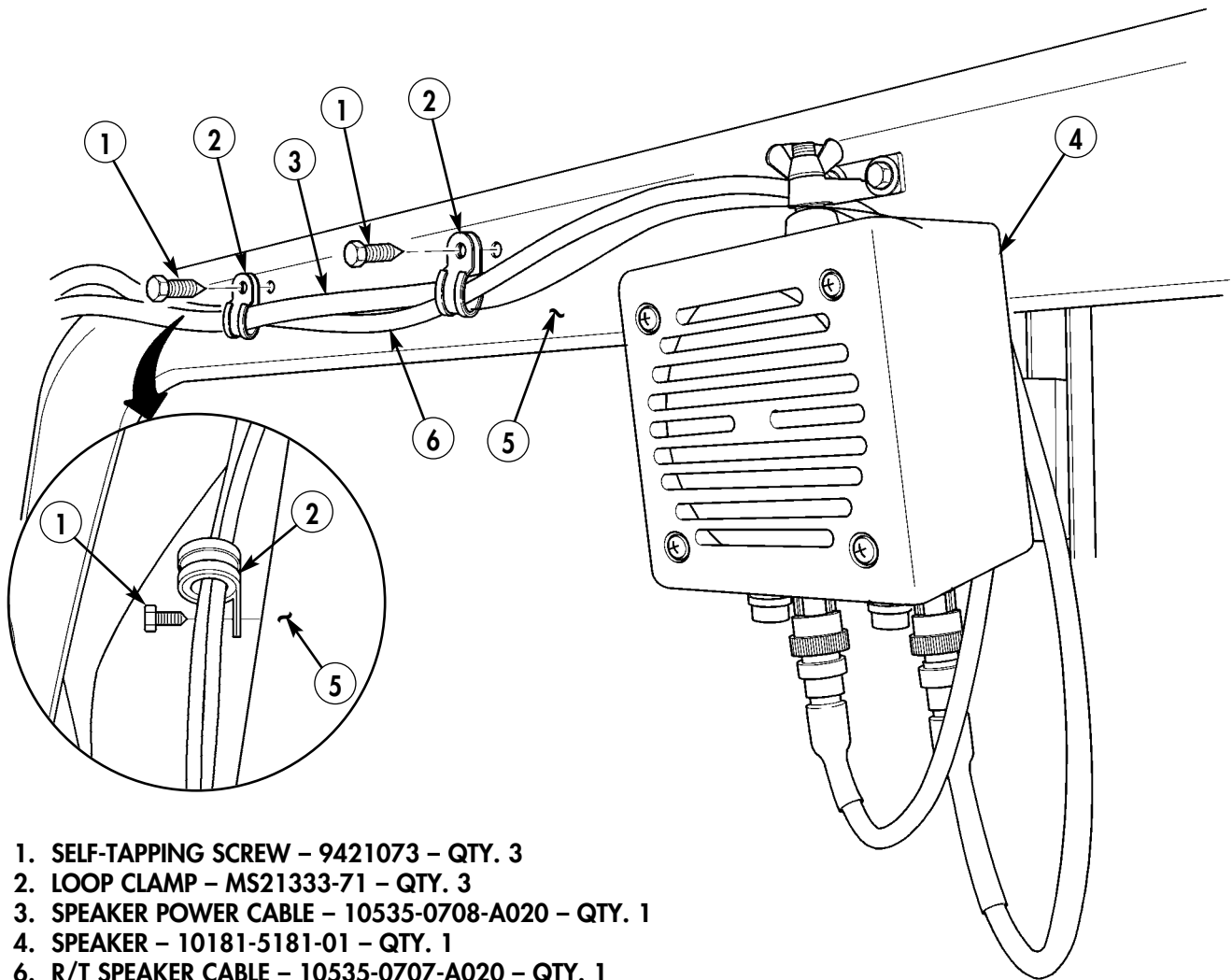

1. SELF-TAPPING SCREW - 9421073 - QTY. 3
2. LOOP CLAMP - MS21333-71 - QTY. 3
3. SPEAKER POWER CABLE - 10535-0708-A020 - QTY. 1
4. SPEAKER - 10181-5181-01 - QTY. 1
6. R/T SPEAKER CABLE - 10535-0707-A020 - QTY. 1

Figure 5-106.

NOTE

Route SINCGARS antenna cable down B-beam with two man configuration only.

- 29-2. Route speaker cables (3) and (6) and SINCGARS antenna cable (19) down B-pillar (5) and secure with three existing loop clamps (18) and capscrews (17).
- 29-3. Route speaker power cable (3) to terminal board and secure with footman loop (8), loop clamp (9), and existing capscrew (7).
- 29-4. Route speaker R/T cable (6) and SINCGARS antenna cable (19) from overhead mount (20) along cab enclosure panel (12) and secure with three existing loop clamps (10) and capscrews (11).
- 29-5. Route speaker R/T cable (6) through tunnel (15) to HF 20 watt radio mount. Secure cable to tunnel (15) with loop clamps (13) and capscrews (14).
- 29-6. Route SINCGARS antenna cable (19) through cab enclosure panel (12) under tunnel insulation, through integrated rack (16), to vicinity of SINCGARS mount.

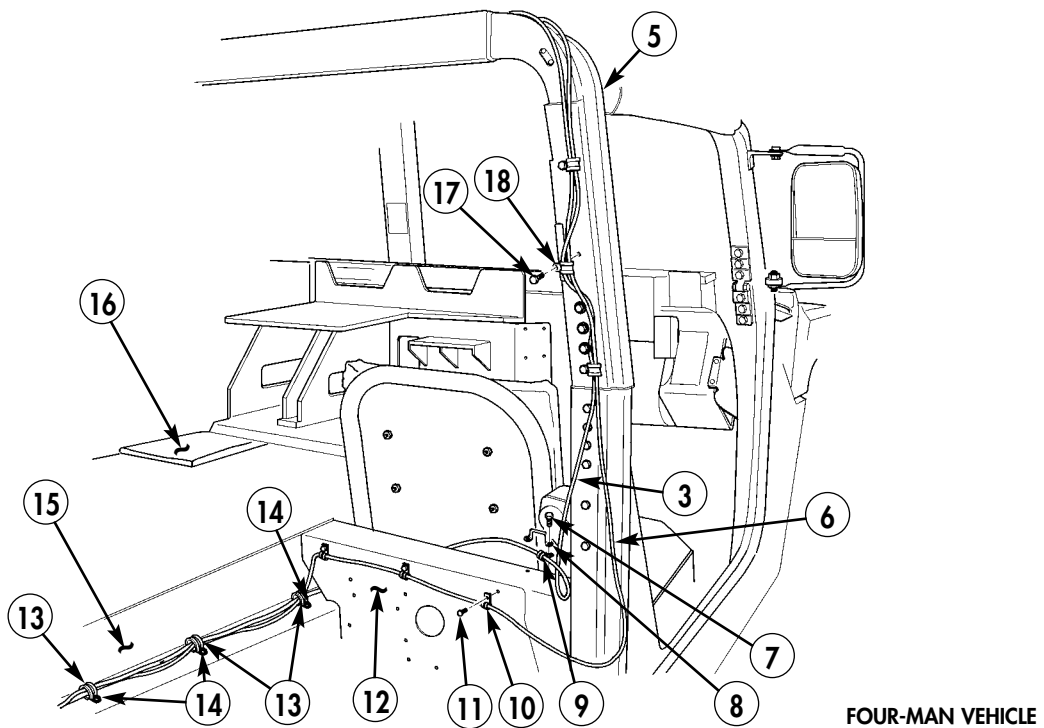

FOUR-MAN VEHICLE

Figure 5-107.

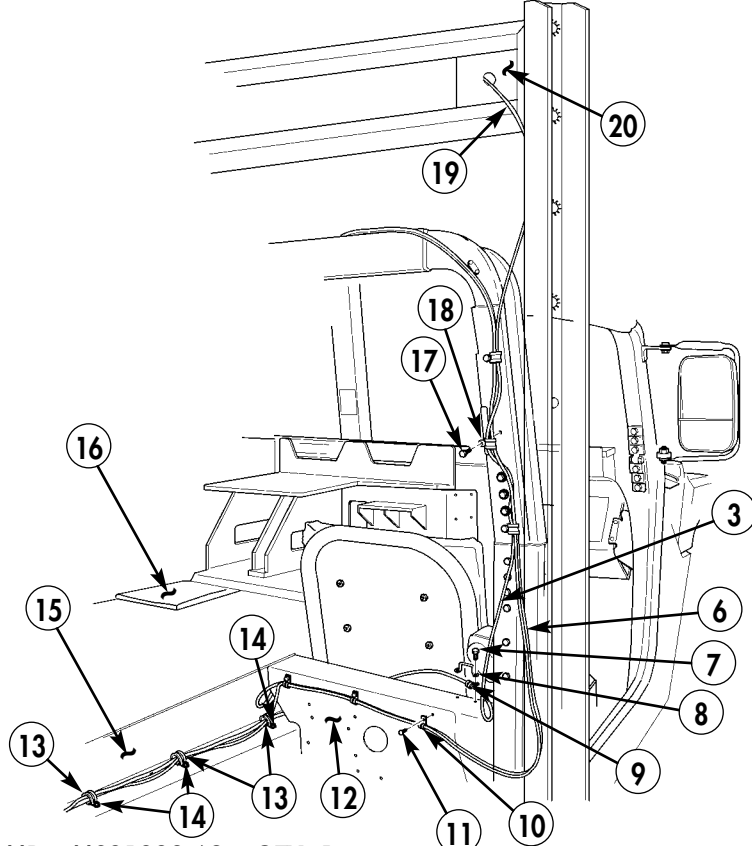

TWO-MAN VEHICLE

- 9. LOOP CLAMP - MS21333-69 - QTY. 1
- 13. LOOP CLAMP - MS21333-75 - QTY. 3
- 14. SELF-TAPPING SCREW - 1234299-1 - QTY. 3

Figure 5-108.

- 29-7. Locate, mark, and drill four 0.147-in. holes (21) in left rear wheelhouse (26).
- 29-8. Locate, mark, and drill one 1.875-in. hole (25) in fixed rear door (24).
- 29-9. Locate, mark, and drill three 0.219-in. holes (22) on rear inside lip of left rear seat back support (23).

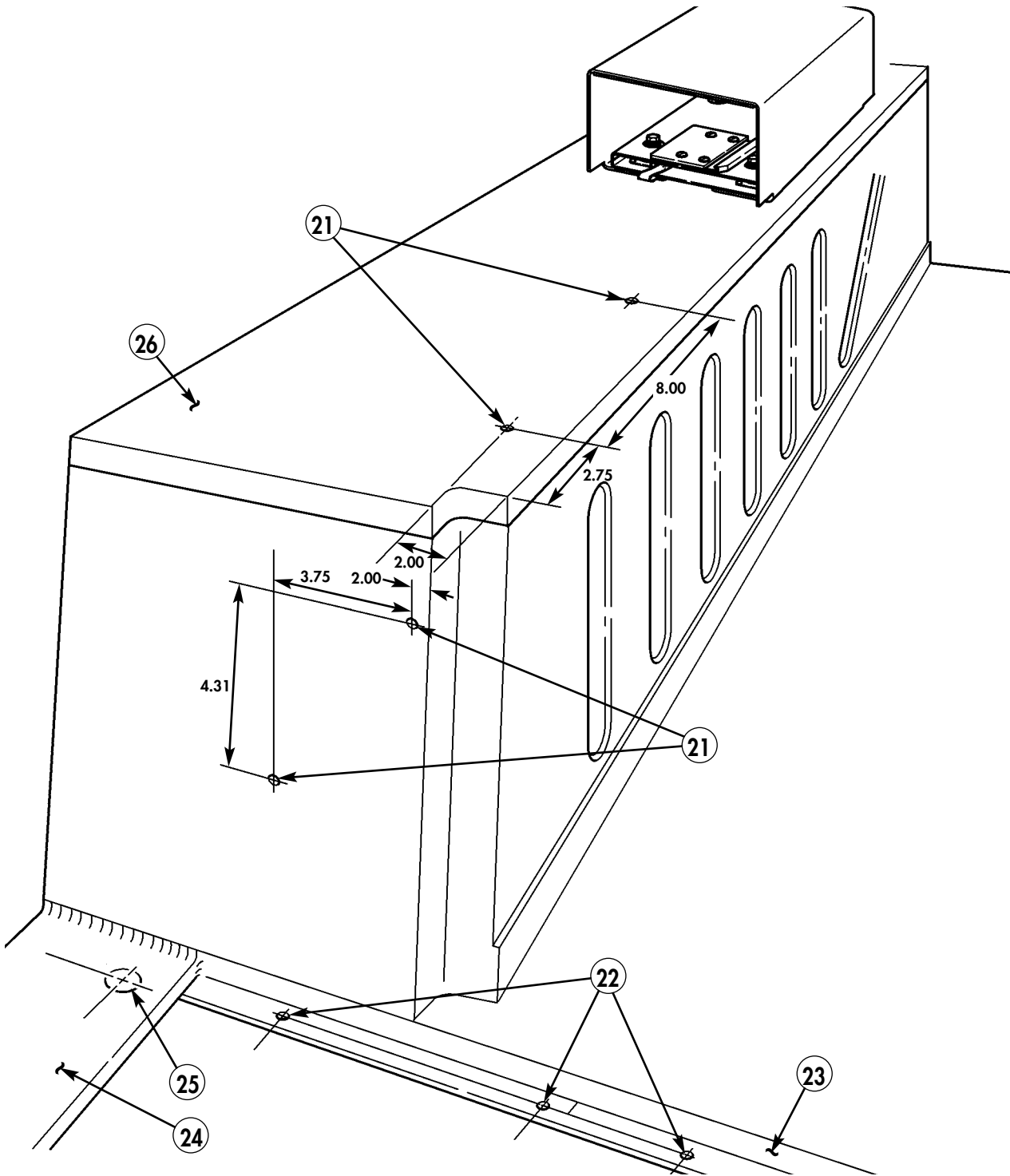

Figure 5-109.

NOTE

Cut split in grommet to fit cables.

- 29-10. Position grommet (33) over cables (6), (28), and (29).
- 29-11. Install grommet (33) in hole (25).
- 29-12. Route cables (6), (28), and (29) under fixed rear door (24) and along rear perimeter of left rear seat back support (23). Secure cables (6), (28), and (29) to left seatback support (23) with three loop clamps (30), screws (31), and plain-assembled nuts (32).
- 29-13. Route cables (6), (28), and (29) through access hole (25) and grommet (33).
- 29-14. Secure cables (6), (28), and (29) to left rear wheelhouse (26) with four loop clamps (30) and self-tapping screws (27).
- 29-15. Take all slack out of cables and store in seat well/utility area.
- 29-16. Tighten screws and nuts on all clamps.
- 29-17. Secure right-side tunnel insulation. (Refer to TM 9-2320-280-20.)

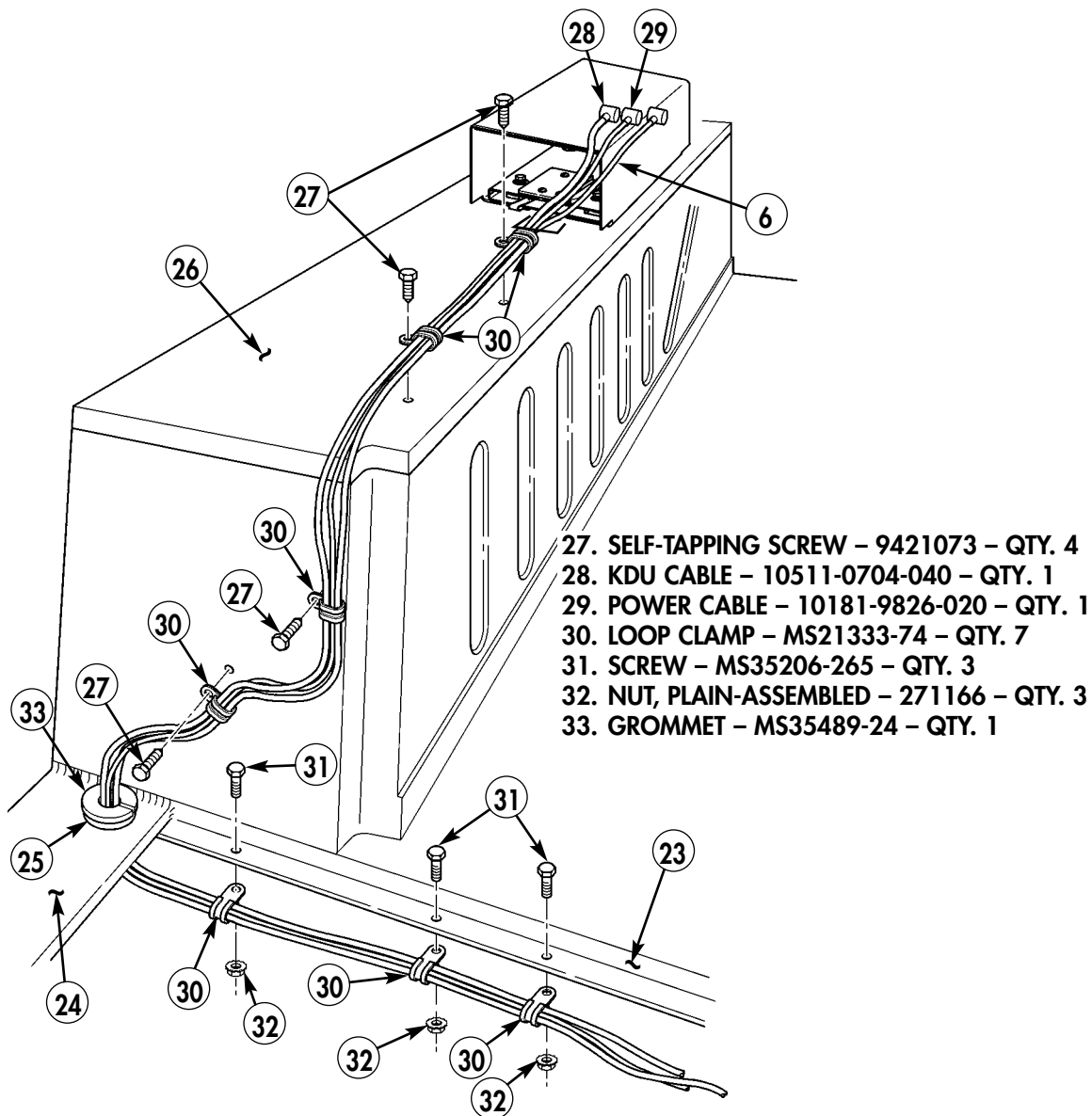

Figure 5-110.

- 29-18. Route cables (6), (28), and (29) through tunnel (15) and secure with existing loop clamps (34) and self-tapping screws (35).
- 29-19. Route HF 20 watt radio power cable (28) to terminal boards.
- 29-20. Route KDU cable (29) through cab enclosure panel and under tunnel insulation.

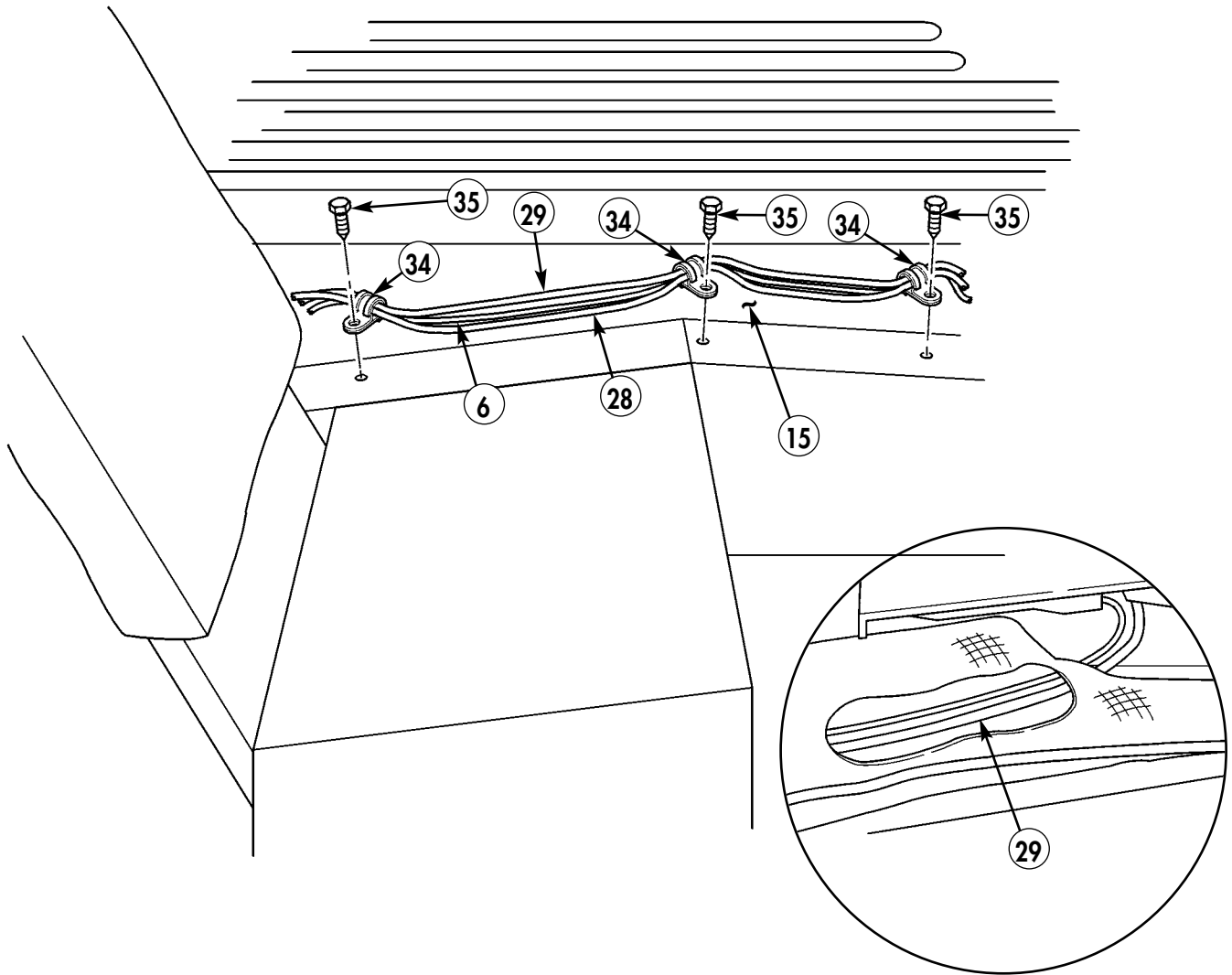
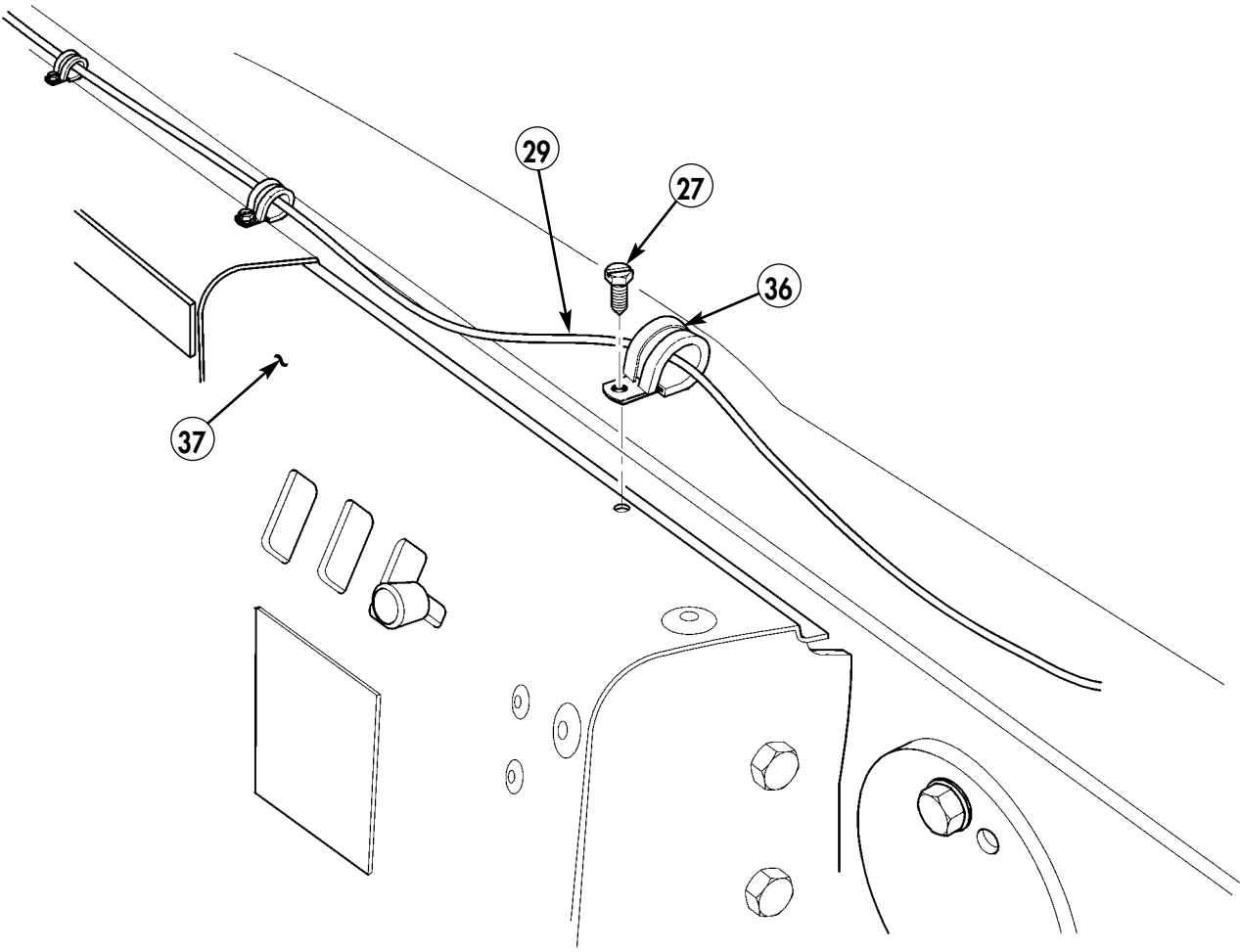

Figure 5-111.

29-21. Route KDU cable (29) along plenum (37) and secure with three loop clamps (36) and self-tapping screws (27).



- 27. SELF-TAPPING SCREW - 9421073 - QTY. 3**
- 40. LOOP CLAMP - MS21333-66 - QTY. 3**

Figure 5-112.

By Order of the Secretary of the Army:

PETER J. SCHOOMAKER
General, United States Army
Chief of Staff

Official:



SANDRA R. RILEY
Administrative Assistant to the
Secretary of the Army
0533603

Distribution:

To be distributed in accordance with the Initial Distribution Number (IDN) 344840 requirements for TB 9-2320-280-35-13.

RECOMMENDED CHANGES TO PUBLICATIONS AND BLANK FORMS For use of this form, see AR 25-30; the proponent agency is ODISC4.	Use Part II (reverse) for Repair Parts and Special Tools Lists (RPSTL) and Supply Catalogs/Supply Manuals (SC/SM).	DATE: <p style="text-align: right;">28 Feb. 2006</p>
---	--	--

TO: <i>(Forward to proponent of publication or form) (include ZIP code)</i> AMSTA-LC-LMIT/Tech Pubs, TACOM-RI 1 Rock Island Arsenal Rock Island, IL 61299-7630	FROM: <i>(Activity and location) (include ZIP code)</i> <p style="text-align: center;">Co. B, 1st BN, 2nd Brigade Ft. Hood, TX 76445</p>
--	--

PART I - ALL PUBLICATIONS (EXCEPT RPSTL AND SC/SM) AND BLANK FORMS

PUBLICATION/FORM NUMBER <p style="text-align: center;">TB 9-2320-280-35-13</p>	DATE <p style="text-align: center;">28 FEB. 2006</p>	TITLE <p style="text-align: center;">TECHNICAL BULLETIN INSTALLATION INSTRUCTIONS</p>
---	---	---

ITEM NO.	PAGE NO.	PARA-GRAPH	LINE NO.*	FIGURE NO.	TABLE NO.	RECOMMENDED CHANGES AND REASON <i>(Provide exact wording of recommended changes, if possible)</i>
----------	----------	------------	-----------	------------	-----------	--

26-1	5-84			5-102		<p style="text-align: center;">Hole (9) should be 0.225-in. in diameter.</p>
------	------	--	--	-------	--	--

SAMPLE

**Reference to line numbers within the paragraph or subparagraph.*

TYPED NAME, GRADE, OR TITLE <p style="text-align: center;">Pat Smith</p>	TELEPHONE EXCHANGE/AUTOVON, PLUS EXTENSION <p style="text-align: center;">AV272-4162</p>	SIGNATURE <p style="text-align: center;"><i>Pat Smith</i></p>
--	---	--

TO: <i>(Forward direct to addressee listed in publication)</i> AMSTA-LC-LMIT/Tech Pubs, TACOM-RI 1 Rock Island Arsenal Rock Island, IL 61299-7630	FROM: <i>(Activity and location) (include ZIP code)</i>	DATE: 28 Feb. 2006
--	---	------------------------------

PART II - REPAIR PARTS AND SPECIAL TOOLS LISTS AND SUPPLY CATALOGS/SUPPLY MANUALS

PUBLICATION/FORM NUMBER TB 9-2320-280-35-13	DATE 28 FEB. 2006	TITLE TECHNICAL BULLETIN INSTALLATION INSTRUCTIONS
---	-----------------------------	--

PAGE NO.	COLM NO.	LINE NO.	NATIONAL STOCK NUMBER	REFERENCE NO.	FIGURE NO.	ITEM NO.	TOTAL NO. OF MAJOR ITEMS SUPPORTED	RECOMMENDED ACTION
SAMPLE								

PART III - REMARKS *(Any general remarks or recommendations, or suggestions for improvement of publications and blank forms. Additional blank sheets may be used if more space is needed.)*

--	--	--

TYPED NAME, GRADE, OR TITLE	TELEPHONE EXCHANGE/AUTOVON, PLUS EXTENSION	SIGNATURE
-----------------------------	--	-----------

RECOMMENDED CHANGES TO PUBLICATIONS AND BLANK FORMS For use of this form, see AR 25-30; the proponent agency is ODISC4.				Use Part II (reverse) for Repair Parts and Special Tools Lists (RPSTL) and Supply Catalogs/Supply Manuals (SC/SM).		DATE:
TO: <i>(Forward to proponent of publication or form) (include ZIP code)</i> AMSTA-LC-LMIT/Tech Pubs, TACOM-RI 1 Rock Island Arsenal Rock Island, IL 61299-7630				FROM: <i>(Activity and location) (include ZIP code)</i>		
PART I - ALL PUBLICATIONS (EXCEPT RPSTL AND SC/SM) AND BLANK FORMS						
PUBLICATION/FORM NUMBER TB 9-2320-280-35-13			DATE 28 FEB. 2006		TITLE TECHNICAL BULLETIN INSTALLATION INSTRUCTIONS	
ITEM NO.	PAGE NO.	PARA-GRAPH	LINE NO.*	FIGURE NO.	TABLE NO.	RECOMMENDED CHANGES AND REASON <i>(Provide exact wording of recommended changes, if possible)</i>
<i>*Reference to line numbers within the paragraph or subparagraph.</i>						
TYPED NAME, GRADE, OR TITLE				TELEPHONE EXCHANGE/AUTOVON, PLUS EXTENSION		SIGNATURE

TO: <i>(Forward direct to addressee listed in publication)</i> AMSTA-LC-LMIT/Tech Pubs, TACOM-RI 1 Rock Island Arsenal Rock Island, IL 61299-7630	FROM: <i>(Activity and location) (include ZIP code)</i>	DATE:
--	---	-------

PART II - REPAIR PARTS AND SPECIAL TOOLS LISTS AND SUPPLY CATALOGS/SUPPLY MANUALS

PUBLICATION/FORM NUMBER TB 9-2320-280-35-13	DATE 28 FEB. 2006	TITLE TECHNICAL BULLETIN INSTALLATION INSTRUCTIONS
--	----------------------	--

PAGE NO.	COLM NO.	LINE NO.	NATIONAL STOCK NUMBER	REFERENCE NO.	FIGURE NO.	ITEM NO.	TOTAL NO. OF MAJOR ITEMS SUPPORTED	RECOMMENDED ACTION

PART III - REMARKS *(Any general remarks or recommendations, or suggestions for improvement of publications and blank forms. Additional blank sheets may be used if more space is needed.)*

--	--	--

TYPED NAME, GRADE, OR TITLE	TELEPHONE EXCHANGE/AUTOVON, PLUS EXTENSION	SIGNATURE
-----------------------------	--	-----------

RECOMMENDED CHANGES TO PUBLICATIONS AND BLANK FORMS For use of this form, see AR 25-30; the proponent agency is ODISC4.	Use Part II (reverse) for Repair Parts and Special Tools Lists (RPSTL) and Supply Catalogs/Supply Manuals (SC/SM).	DATE:
---	--	-------

TO: <i>(Forward to proponent of publication or form) (include ZIP code)</i> AMSTA-LC-LMIT/Tech Pubs, TACOM-RI 1 Rock Island Arsenal Rock Island, IL 61299-7630	FROM: <i>(Activity and location) (include ZIP code)</i>
--	---

PART I – ALL PUBLICATIONS (EXCEPT RPSTL AND SC/SM) AND BLANK FORMS

PUBLICATION/FORM NUMBER TB 9-2320-280-35-13	DATE 28 FEB. 2006	TITLE TECHNICAL BULLETIN INSTALLATION INSTRUCTIONS
---	-----------------------------	--

ITEM NO.	PAGE NO.	PARA-GRAPH	LINE NO.*	FIGURE NO.	TABLE NO.	RECOMMENDED CHANGES AND REASON <i>(Provide exact wording of recommended changes, if possible)</i>
----------	----------	------------	-----------	------------	-----------	--

--	--	--	--	--	--	--

**Reference to line numbers within the paragraph or subparagraph.*

TYPED NAME, GRADE, OR TITLE	TELEPHONE EXCHANGE/AUTOVON, PLUS EXTENSION	SIGNATURE
-----------------------------	--	-----------

TO: <i>(Forward direct to addressee listed in publication)</i> AMSTA-LC-LMIT/Tech Pubs, TACOM-RI 1 Rock Island Arsenal Rock Island, IL 61299-7630	FROM: <i>(Activity and location) (include ZIP code)</i>	DATE:
---	--	--------------

PART II - REPAIR PARTS AND SPECIAL TOOLS LISTS AND SUPPLY CATALOGS/SUPPLY MANUALS

PUBLICATION/FORM NUMBER TB 9-2320-280-35-13	DATE 28 FEB. 2006	TITLE TECHNICAL BULLETIN INSTALLATION INSTRUCTIONS
---	-----------------------------	---

PAGE NO.	COLM NO.	LINE NO.	NATIONAL STOCK NUMBER	REFERENCE NO.	FIGURE NO.	ITEM NO.	TOTAL NO. OF MAJOR ITEMS SUPPORTED	RECOMMENDED ACTION

PART III - REMARKS *(Any general remarks or recommendations, or suggestions for improvement of publications and blank forms. Additional blank sheets may be used if more space is needed.)*

--

TYPED NAME, GRADE, OR TITLE	TELEPHONE EXCHANGE/AUTOVON, PLUS EXTENSION	SIGNATURE

